

CODE NO.	REED'S PARTS NO.	DESCRIPTION	QTY
1	C-.SE	Tank, Hydraulic Oil	1
2	C-.WR	Valve, Inlet	1
3	C-.FF1	Hose, Flexible	1
4	C-.MP	Pump, Hydraulic	1
5	C-.FF2	Hose, Flexible	1
6	C-DM000	Gauge, Pressure	1
7	C-DF101	Filter, Hydraulic	1
8	C-FF143.160	Hose, Flexible	1
9	C-DD103/DD104	Distributor	1
10	C-FF101.170	Hose, Flexible	1
11	C-FF134.370	Hose, Flexible	8
12	C-FF134.125	Hose, Flexible	14
13	C-WL211	Valve, Flow Limiter	1
14	C-WL215	Valve, Flow Limiter	1
15	C-FF134.070	Hose, Flexible	20
16	C-WC226	Valve, Check	2
17	C-WC232	Valve, Check	3
18	C-.B4	Piston, Hydraulic	1
19	C-.B3	Piston, Hydraulic	1
20	C-FF134.090	Hose, Flexible	2
21	C-WC228	Valve, Flow Control	2
22	C-.B2	Piston, Hydraulic	1
23	C-WC225	Valve, Flow Control	1
24	C-.B1	Piston, Hydraulic	1
25	C-FF122.125	Hose, Flexible	6
26	C-WL125	Valve, Two Directional Throttle	2
27	C-WA105	Valve, Over Center	1
28	C-.MI	Motor, Hydraulic	1
29	C-FF101.090	Hose, Flexible	1
30	C-FF101.045	Hose, Flexible	8

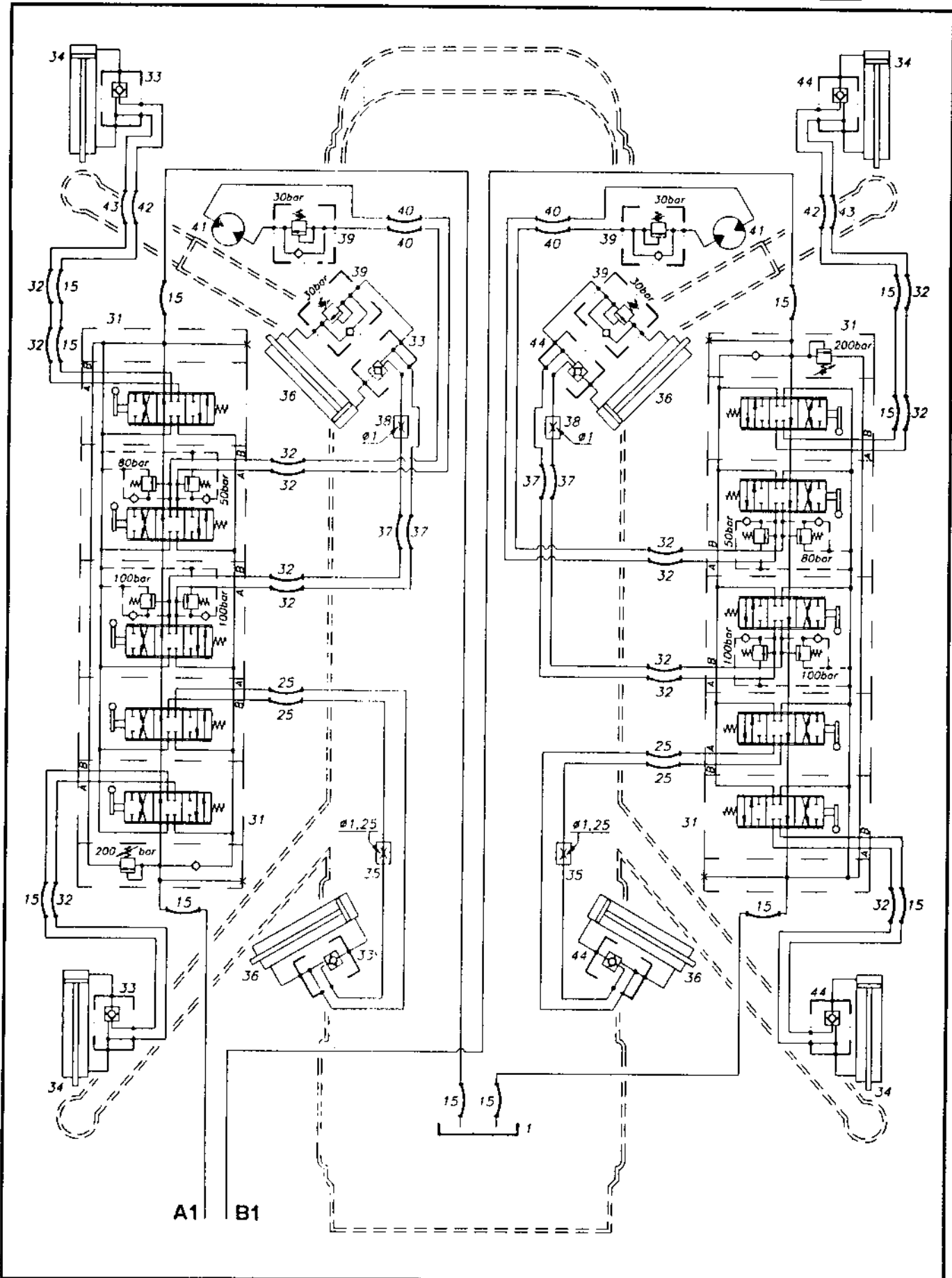



OUTRIGGER AREA HYDRAULIC COMPONENTS

SCMTC

PAGE 03

CODE NO.	REED'S PARTS NO.	DESCRIPTION	QTY
31	C-DD009	Distributor	2
32	C-FF122.070	Hose, Flexible	14
33	C-WD201	Valve, Check	4
34	C-L5	Piston, Hydraulic	4
35	C-WL112	Valve, Two Directional Throttle	2
36	C-M3	Piston, Hydraulic	4
37	C-FF122.060	Hose, Flexible	4
38	C-WL110	Valve, 2 Direction Throttle	2
39	C-WS103	Valve, Sequence	4
40	C-FF122.120	Hose, Flexible	4
41	C-MI1	Motor, Hydraulic	2
42	C-FF134.230	Hose, Flexible	2
43	C-FF122.230	Hose, Flexible	2
44	C-WD202	Valve, Check	4

REVISION:

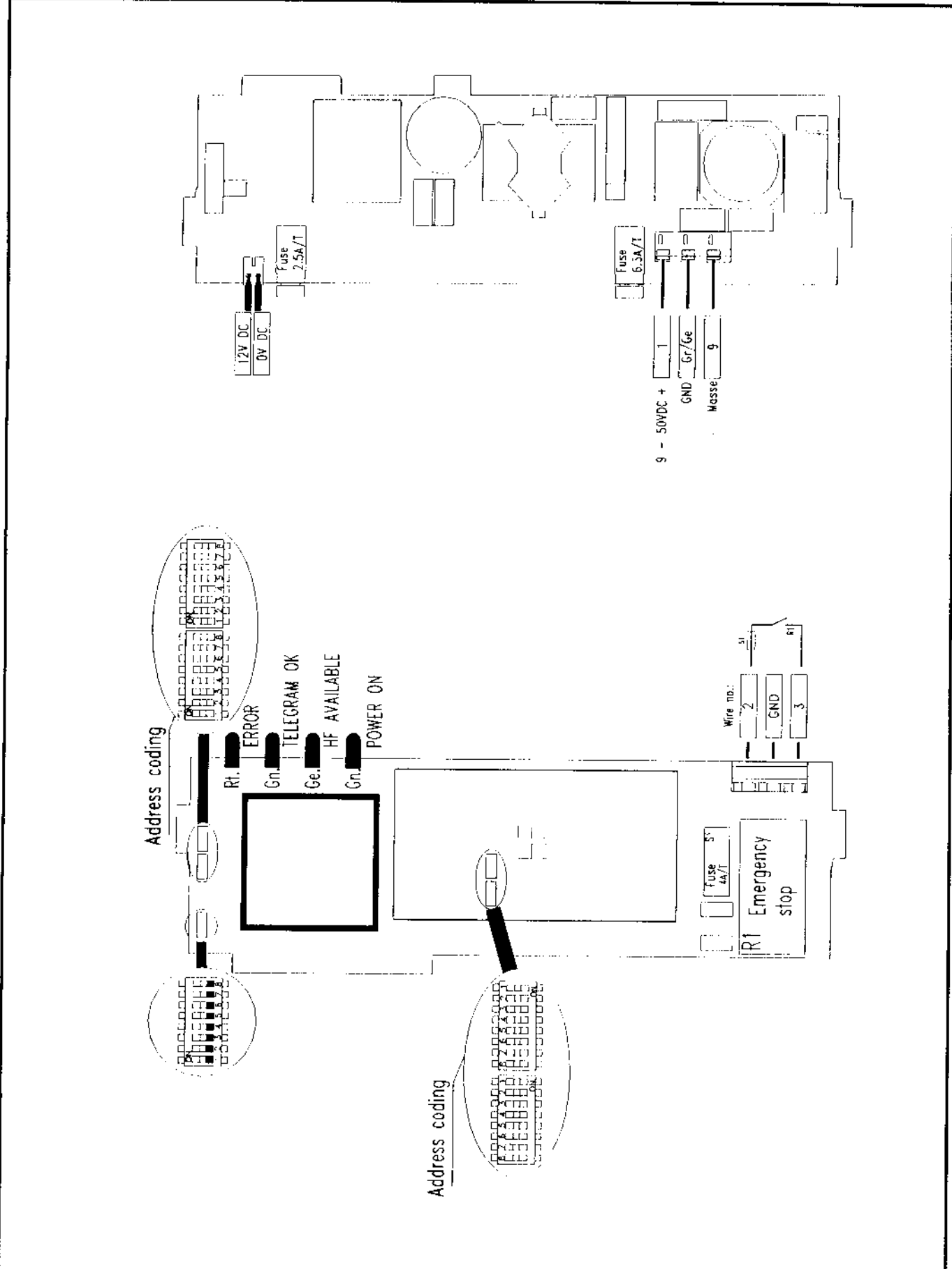



RADIO REMOTE CONTROL WIRING DIAGRAM (SHEET 2 OF 2)

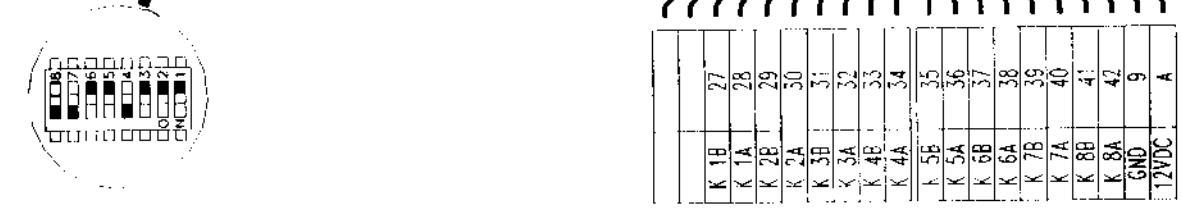
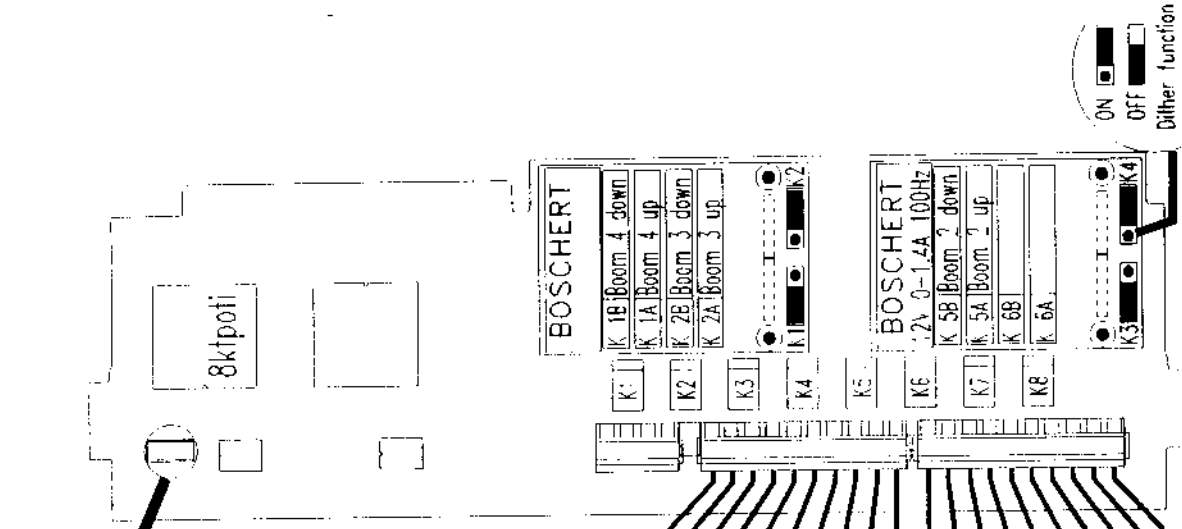
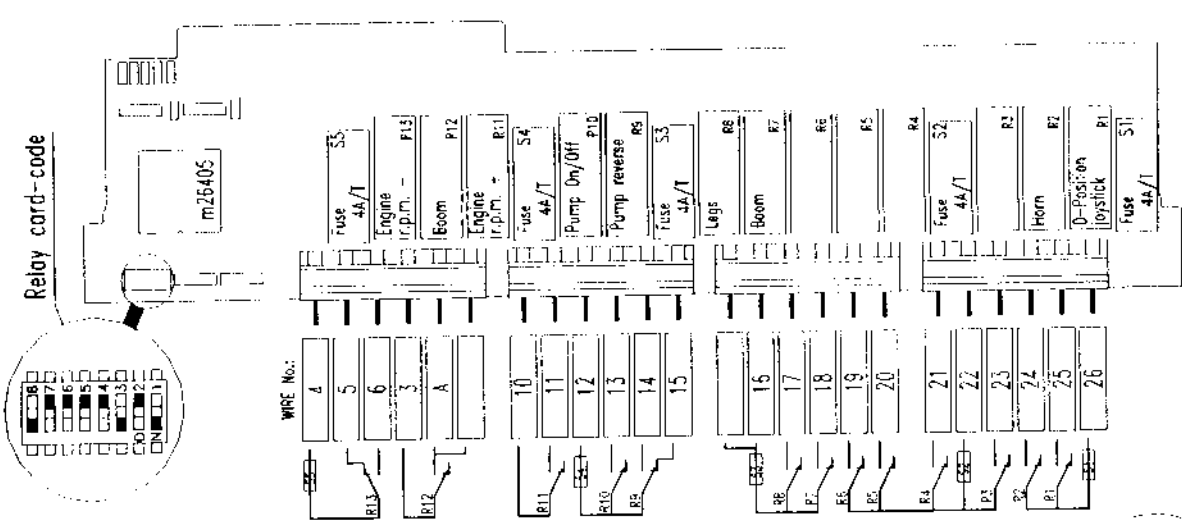

- K1
- K2
- K3
- K4
- K5
- K6
- K7
- K8

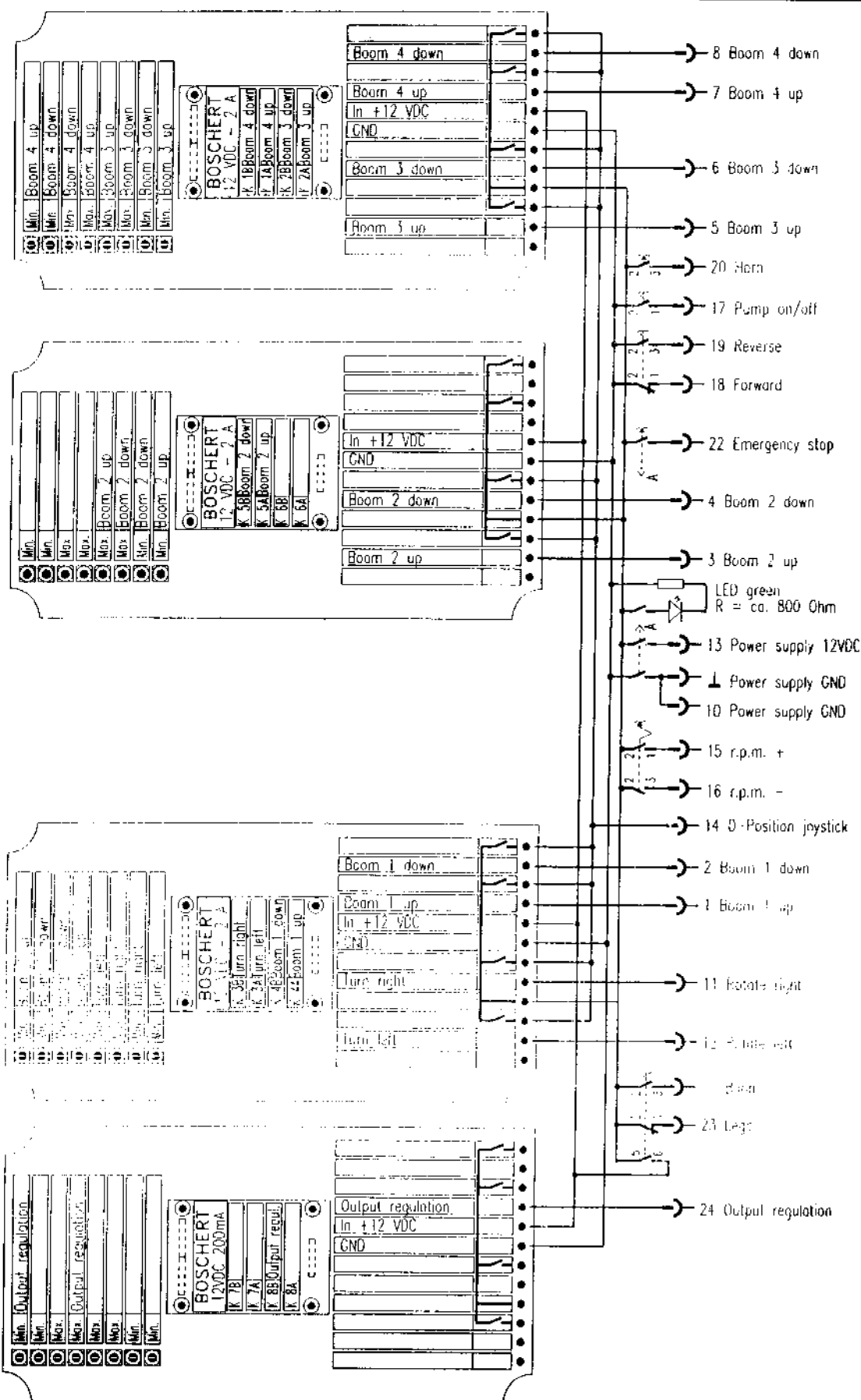

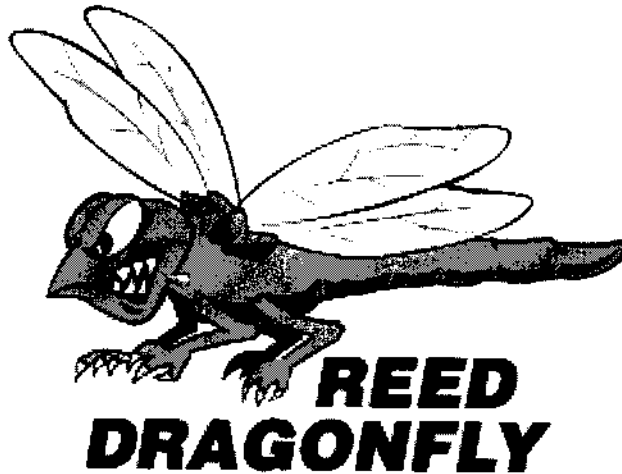

REED TRUCK MOUNTED CONCRETE BOOM PUMP MODEL XXT 42 ILLUSTRATED PARTS MANUAL CONTAINS THE FOLLOWING GROUPS AND FIGURES:

GROUP 00 HOW TO USE PARTS MANUAL

- FIGURE 00** TABLE OF CONTENTS
- FIGURE 01** HOW TO USE PARTS MANUAL
- FIGURE 02** HOW TO ORDER PARTS

GROUP 10 FINAL INSTALLATION

- FIGURE 00** TABLE OF CONTENTS
- FIGURE 01** FINAL INSTALLATION
- FIGURE 02** DECAL ASSEMBLY

GROUP 20 HOPPER INSTALLATION

- FIGURE 00** TABLE OF CONTENTS
- FIGURE 01** HOPPER INSTALLATION
- FIGURE 02** HOPPER HOOK ASSEMBLY
- FIGURE 03** LUBRICATION PUMP ASSEMBLY
- FIGURE 04** HOPPER VIBRATION ASSEMBLY
- FIGURE 05** HOPPER GRID ASSEMBLY
- FIGURE 06** AGITATOR AND WASH CONTROL VALVE ASSEMBLY
- FIGURE 07** AGITATOR ASSEMBLY
- FIGURE 08** AGITATOR DRIVE MOTOR ASSEMBLY
- FIGURE 09** HOPPER OUTLET ASSEMBLY
- FIGURE 10** DRIVE CYLINDER LUBRICATION SYSTEM ASSEMBLY
- FIGURE 11** HOPPER LUBRICATION SYSTEM ASSEMBLY
- FIGURE 12** LUBRICATION DISTRIBUTOR ASSEMBLY

GROUP 30 TANK INSTALLATION

FIGURE 00	TABLE OF CONTENTS
FIGURE 01	TANK INSTALLATION
FIGURE 02	WATER SYSTEM GROUP
FIGURE 03	WASH WATER PUMP ASSEMBLY
FIGURE 04	WATER PUMP MOTOR ASSEMBLY

GROUP 40 POWER TRAIN INSTALLATION

FIGURE 00	TABLE OF CONTENTS
FIGURE 01	POWER TRAIN INSTALLATION
FIGURE 02	GEAR PUMP ASSEMBLY
FIGURE 03	PTO GEARBOX ASSEMBLY

GROUP 50 CONTROLS INSTALLATION

FIGURE 00	TABLE OF CONTENTS
FIGURE 01	CONTROLS INSTALLATION
FIGURE 02	CAB CONTROLS ASSEMBLY
FIGURE 03	MAIN CONTROLS ASSEMBLY
FIGURE 04	DRIVER SIDE OUTRIGGER CONTROLS ASSEMBLY
FIGURE 05	PASSENGER SIDE OUTRIGGER CONTROLS ASSEMBLY
FIGURE 06	STATIONARY BOOM CONTROLS ASSEMBLY
FIGURE 07	CABLED REMOTE CONTROL ASSEMBLY
FIGURE 08	RADIO REMOTE CONTROL ASSEMBLY
FIGURE 09	SHUNT ASSEMBLY

GROUP 60 PUMPING TRAIN INSTALLATION

FIGURE 00	TABLE OF CONTENTS
FIGURE 01	PUMPING TRAIN INSTALLATION
FIGURE 02	SWING VALVE ASSEMBLY
FIGURE 03	TILTING DRIVE ASSEMBLY
FIGURE 04	TILTING CYLINDER ASSEMBLY
FIGURE 05	CONCRETE CYLINDER ASSEMBLY
FIGURE 06	WATER BOX ASSEMBLY
FIGURE 07	HYDRAULIC DRIVE CYLINDER ASSEMBLY
FIGURE 08	DRIVE CYLINDER SUB-ASSEMBLY

GROUP 70 FRAME AND SUPPORT INSTALLATION

FIGURE 00	TABLE OF CONTENTS
FIGURE 01	FRAME AND SUPPORT INSTALLATION
FIGURE 02	TURRET ASSEMBLY
FIGURE 03	MOTOR AND REDUCTION ASSEMBLY
FIGURE 04	ROTATION UNIT ASSEMBLY
FIGURE 05	SUPPORT FRAME STABILIZERS ASSEMBLY
FIGURE 06	FRONT LEFT STABILIZERS TELESCOPIC LEG ASSEMBLY
FIGURE 07	FRONT RIGHT STABILIZERS TELESCOPIC LEG ASSEMBLY
FIGURE 08	REAR LEFT SWING OUT LEG ASSEMBLY
FIGURE 09	REAR RIGHT SWING OUT LEG ASSEMBLY
FIGURE 10	STABILIZERS VERTICAL JACK CYLINDER ASSEMBLY
FIGURE 11	SWING OUT CYLINDER ASSEMBLY

GROUP 80 OPTIONAL INSTALLATION

FIGURE 00	TABLE OF CONTENTS
FIGURE 01	OPTIONAL INSTALLATION
FIGURE 02	ACCUMULATOR CHARGE KIT
FIGURE 03	OPTIONAL TOOL KIT ASSEMBLY

GROUP 90 BOOM INSTALLATION

FIGURE 00	TABLE OF CONTENTS
FIGURE 01	BOOM INSTALLATION
FIGURE 02	FIRST BOOM ASSEMBLY
FIGURE 03	SECOND BOOM ASSEMBLY
FIGURE 04	THIRD BOOM ASSEMBLY
FIGURE 05	FOURTH BOOM ASSEMBLY
FIGURE 06	FIRST BOOM CYLINDER ASSEMBLY
FIGURE 07	SECOND BOOM CYLINDER ASSEMBLY
FIGURE 08	THIRD BOOM CYLINDER ASSEMBLY
FIGURE 09	FOURTH BOOM CYLINDER ASSEMBLY
FIGURE 10	CONCRETE DECK PIPELINE ASSEMBLY
FIGURE 11	CONCRETE BOOM PIPELINE ASSEMBLY



**MODEL XXT 42 TRUCK MOUNTED
CONCRETE BOOM PUMP
HOW TO USE PARTS MANUAL**

**XXT 42
PARTS
GROUP 00
FIGURE 01
PAGE 01**

I. PURPOSE

This parts manual is prepared, issued and/or revised by **REED** Manufacturing, for the exclusive use of its customers and is intended for use in provisioning, requisitioning, storing and issuing replaceable **REED** truck mounted concrete boom pump model **XXT 42**. The contents are proprietary to **REED** and are subject to change without notice. The use of any part of this document by any other person or persons or for any other purpose without the written consent of **REED** is expressly prohibited. In addition, **REED** expressly disclaims any and all responsibility arising in or any way related to such **REED'S** prior written consent thereto.

The parts number content of this document, arrangement and breakdown sequence of items is compatible with Military Standard (**MS**) and Air Transport Association Specification (**ATA**).

II. GENERAL SYSTEM OF ASSEMBLY ORDER – Detailed Parts List (Refer to Next Page)

1. This area refers to the corresponding illustration

MODEL – GROUP – FIGURE – PAGE

A. MODEL shows which is **REED's** model number.

B. GROUP should be divided with:

00	MODEL XXT 42 ILLUSTRATED PARTS MANUAL
10	FINAL INSTALLATION
20	HOPPER INSTALLATION
30	TANK INSTALLATION
40	POWER TRAIN INSTALLATION
50	CONTROL INSTALLATION
60	PUMPING TRAIN INSTALLATION
70	FRAME AND SUPPORT INSTALLATION
80	OPTIONAL INSTALLATION
90	BOOM INSTALLATION

C. FIGURE belong to the group. Please see page of contents and each group.

D. PAGE numbers follow to the right of each figure number.

2. The **ITEM NUMBER** corresponds to the item number shown for the part in illustration. Parts with item number proceeded by a dash (such as: -1, -5, -12 etc.) are not illustrated.

3. **PARTS NUMBERS** that carry a **REED** part number.



MODEL XXT 42 TRUCK MOUNTED CONCRETE BOOM PUMP HOW TO USE PARTS MANUAL

**XXT 42
PARTS**
GROUP 00
FIGURE 01
PAGE 02



HYDRAULIC PUMPING ASSEMBLY

**XXT 42
PARTS**
GROUP 60
FIGURE 06
PAGE 02

ITEM NO.	REED'S PARTS NO.	DESCRIPTION					QTY
		1	2	3	4	5	
-1	60-06	Assembly, Hydraulic Pumping (See Group 20, Figure 01 for NHA)					Ref
2	78154	• Cup, Piston					2
3	78444	• Coupler					2
4	78152	• Coupling, Dog bone					4
5		• Bolt 1/2 x 4 (attaching parts)					8
6		• Nut, 1/2 (attaching parts)					8
7	78443	• Bone, Dog					2
8		• Bolt 5/8 x 2					6
9	78442	• Coupler					2
10	78438	• Assembly, Hydraulic Cylinder (See Group 60, Figure 07 for DET)					1
11		• Nut (attaching parts)					16
12		• Washer (attaching parts)					16
13	77617	• Bolt (attaching parts)					16
14		• Elbow, 90 FS6802-16-16					4
15	79343	• Assembly, Hose					2
16	78593	• Fitting, MiniCheck (Port)					2
17		• Elbow, 90 FS6802-06-06					4
18		• Fitting, STR FS6100-06-06					4
19	79144	• Assembly, Hose					2
20		• Elbow, 90 FS6801-06-06					4
21		• Valve, Check					4
22		• Elbow, 90 NIBM190-06-06					4
23		• Clamp					3
24	79326	• Tube, Wire					1
25	79345	• Assembly, Tube					2
26	78417	• Cable					2
27	72010	• Loom, 1/2 Flex					A/R
28		• Pin, 1/4 x 20					4
29	79285	• Cover, Proximity Switch					2
30	78416	• Switch, Proximity					2
31	79327	• Plate, End					1
32		• Washer, 1 Lock (attaching parts)					8
33		• Bolt, 1 x 2 Coarse (attaching parts)					8

DASH (-) ITEM NOT ILLUSTRATED

REVISION:



REVISION:



MODEL XXT 42 TRUCK MOUNTED CONCRETE BOOM PUMP HOW TO USE PARTS MANUAL

XXT 42
PARTS
GROUP 00
FIGURE 01
PAGE 03



HYDRAULIC PUMPING ASSEMBLY

XXT 42
PARTS
GROUP 60
FIGURE 08
PAGE 02

ITEM NO.	REED'S PARTS NO.	DESCRIPTION	QTY
-1	60-06	Assembly, Hydraulic Pumping (See Group 20, Figure 01 for NHA)	Ref
2	78354	* Cap, Piston	2
3	78444	* Coupler	2
4	78352	* Coupling, Dog bone	4
5		* Bolt 1/2 x 4 (attaching parts)	8
6		* Nut, 1/2 (attaching parts)	8
7	78443	* Bone, Dog	2
8		* Bolt 5/8 x 2	6
9	78442	* Coupler	2
10	78438	* Assembly, Hydraulic Cylinder (See Group 60, Figure 07 for DET)	1
11		* Nut (attaching parts)	16
12		* Washer (attaching parts)	16
13	77617	* Bolt (attaching parts)	16
14		* Elbow, 90 FS6802-16-16	4
15	79143	* Assembly, Hose	2
16	78591	* Fitting, MiniCheck (Port)	2
17		* Elbow, 90 FS6802-06-06	4
18		* Fitting, STR FS6800-06-06	4
19	79144	* Assembly, Hose	2
20		* Elbow, 90 FS6801-06-06	4
21		* Valve, Check	4
22		* Elbow, 90 MBMB90-06-06	4
23		* Clamp	3
24	79126	* Tube, Wire	1
25	79145	* Assembly, Tube	2
26	78417	* Cable	2
27	72010	* Loom, 1/2 Flex	A/R
28		* Pin, 1/4 x 20	4
29	79285	* Cover, Proximity Switch	2
30	78416	* Switch, Proximity	2
31	79327	* Plate, End	1
32		* Washer, U Lock (attaching parts)	8
33		* Bolt, 1 x 2 Course (attaching parts)	8

DASH (-) ITEM NOT ILLUSTRATED

REVISION:



REVISION:

4. DESCRIPTION

- A. The **INDENTURE SYSTEM** used in the parts list shows the relationship of one part to another. For a given item, the number of indentures depicts the relationship of the item to the components of the item as follows:

1 2 3 4 5

Assembly (or Installation)

- Detail part of assembly
- Sub-assembly
- Attaching parts for sub-assembly
- ● Detail part of sub-assembly
- ● Sub-sub-assembly
- ● Attaching parts for sub-sub-assembly
- ● ● Detail part of sub-sub-assembly
- ● ● Sub-sub-sub-assembly
- ● ● Attaching parts of sub-sub-sub-assembly
- ● ● ● Detail part of sub-sub-sub-assembly

- B. "See Group 20, Figure 01 For **NHA**"
Identifies the illustrated parts chapter location; indicates where the Next Higher Assembly (**NHA**) of the item shown.
- C. "See Group 60, Figure 07 For **DET**"
Identifies the illustrated parts chapter location; indicates where the item and its Detailed Breakdown (**DET**) is shown.
- D. "See Group 30, Figure 05 for **REF**" or "See Vendor Chapter For **REF**"
Identifies the illustrated parts chapter where the part is, and if listed and illustrated in Vendor Chapter. It is used as a cross-reference (**REF**).

5. QUANTITY

- A. Reference (**REF**) indicates the items that is listed previously in the Next Higher Assembly (**NHA**) and then again in this figure.
- B. As Required (**A/R**) indicates the parts that is used in a quantity as required.
- C. A number entry indicates the quantity of the part used in its next higher application.
6. Functionally related assemblies are illustrated in phantom (_____) but not listed on the detail parts list page.

1. Always give serial number and model of **REED** truck mounted concrete boom pump model: **XXT 42**. (Refer to each unit name plate shown below). NOTE: This manual is being released to cover unit starting with serial number 00 - 209 - **XXT 42** to current production. Some components used on earlier units differ from current productions. Where this occurs, the part is identified by a serial number.

REED		PHONE (909) 364-2100		CE
11721 PARK AVENUE CHINO, CA 90710 USA		FAX (909) 364-2140		
MODEL	_____	SERIAL NO	_____	
HYD PRESSURE	_____	PSI	_____	BAR
ELECTRIC MOTOR/ ENGINE SPEED	_____	RPM	_____	VOLTS
VEHICLE WEIGHT (APPROX)	_____	LBS	_____	KG

2. Always specify part number and complete name of parts ordered.
- A. Turn to table of content in the desired Installation.
Refer to main group in which part should be listed.

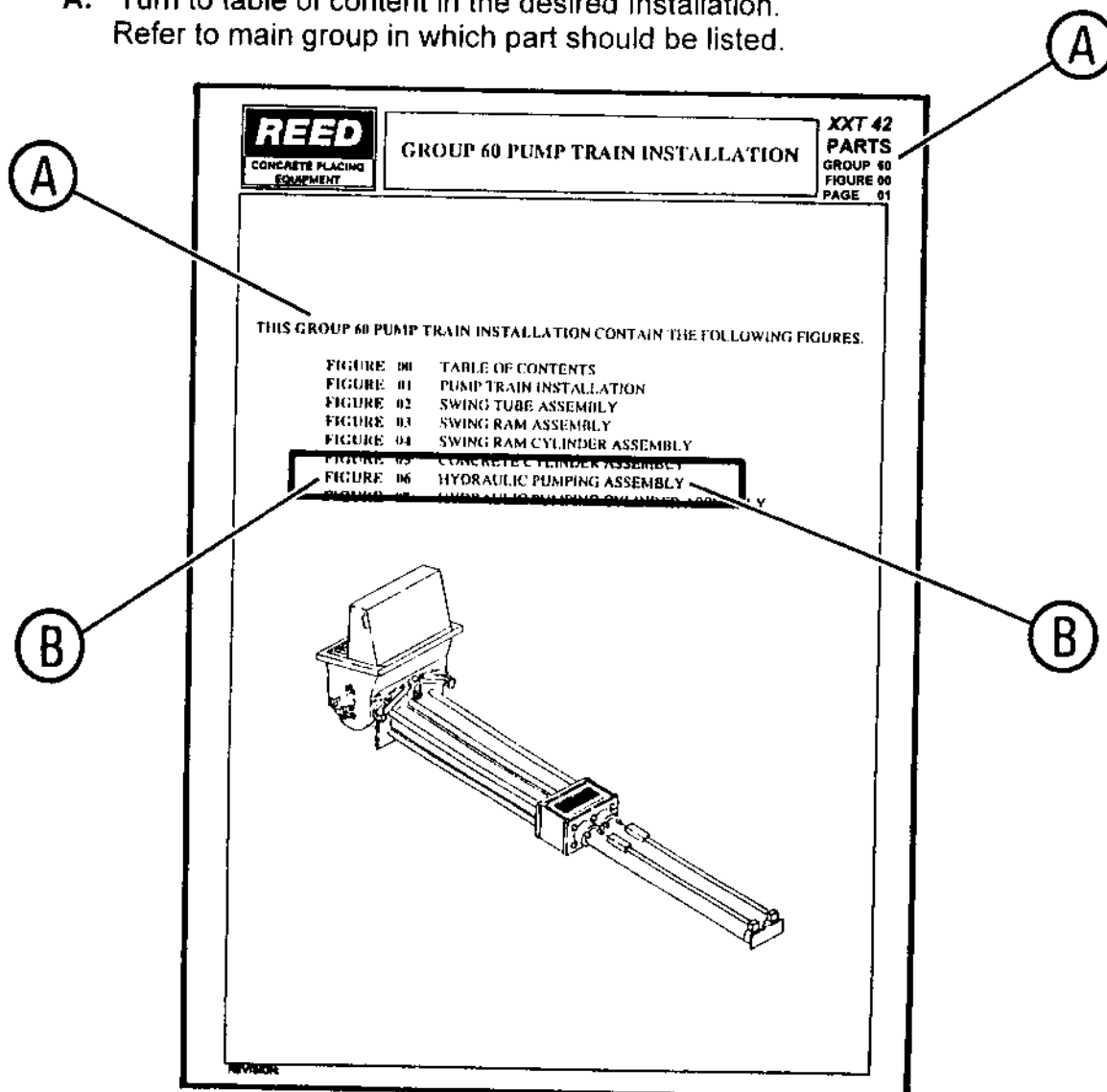

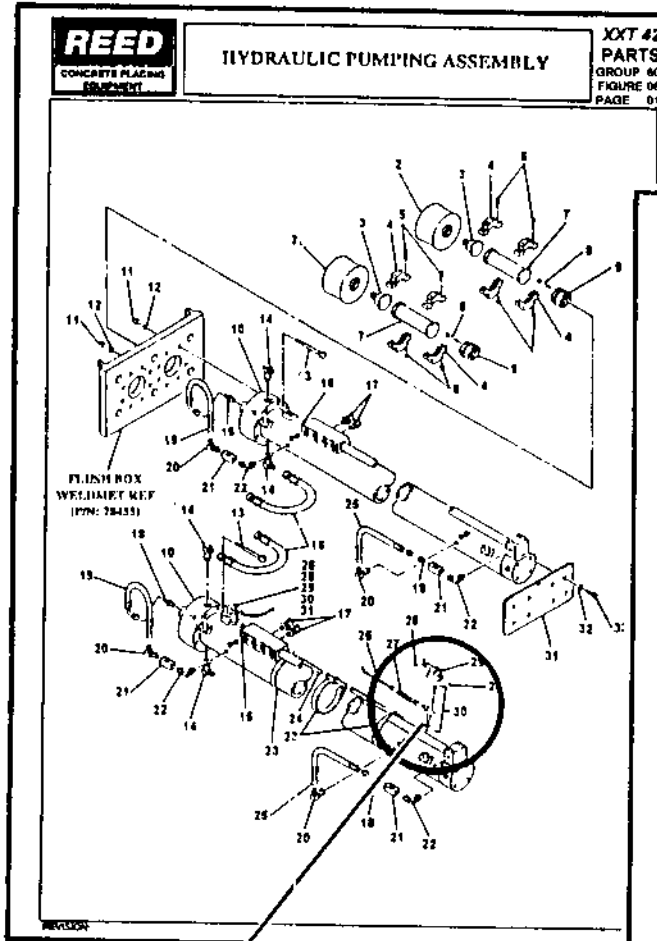

XXT 42
PARTS
GROUP 00
FIGURE 06
PAGE 01

ITEM NO.	REED'S PARTS NO.	DESCRIPTION	QTY
1	61106	Assembly, Hydraulic Pump (See Group 20, Figure 1 for NHA)	Ref
2	78154	* Cap, Piston	2
3	78212	* Coupler	2
4	78152	* Coupler, Day Use	4
5		* Nut, 1/2 x 4 (see attaching parts)	8
6		* Nut, 1/2 (attaching parts)	8
7	78411	* Hose, 1/2"	2
8		* Nut, 3/8 x 2	6
9	78412	* Coupler	2
10	78418	* Assembly, Hydraulic Cylinder (See Group 40, Figure D3 for DPT)	1
11		* Nut (attaching parts)	16
12		* Washer (attaching parts)	16
13	77677	* Bolt for (attaching parts)	16
14		* Flange, 3/4 FNAM12-16-16	4
15	79141	* Assy, 1/2" Hose	2
16	78571	* Flt, 1/2" Stud Bolt (Part)	2
17		* Flt, 1/2" FNAM12-16-16	2
18		* Flt, 1/2" STR 1/2-20-16-16	4
19	79142	* Assy, 1/2" Hose	2
20		* Flt, 1/2" FNAM12-16-16	4
21		* Flt, 1/2" Check	4
22		* Flt, 1/2" FNAM12-16-16	4
23		* Flt, 1/2" FNAM12-16-16	4
24	79126	* Clamp	1
25	79145	* Cable, Wire	1
26	78417	* Assembly, Tube	2
27	78417	* Cable	2
28	72010	* Flange, 1/2 Flange	A/R
29		* Flt, 1/4 x 20	4
30	79287	* Switch, Proximity	2
31	78276	* Switch, Proximity	2
32		* Washer, 1 Lock (attaching parts)	8
33		* Nut, 1/2 x 2 (attaching parts)	8

DASHED ITEM NOT ILLUSTRATED

- B. Find title of figure in which the part should be shown. Note figure number.
- C. Turn to corresponding page, find the group and figure.
- D. Check your required part and its attaching parts and match with illustration page.
- E. Refer to corresponding item number in the part list page. Part numbers are located in the part number column.
- F. When ordering variable or optional miscellaneous parts which are not found this in parts chapter, follow the above outlined procedure of how to order parts.
 - 1). When applicable, give model and serial number of the component for which parts are desired.
 - 2). In a specific, difficult to describe situation, a marked-up photograph or detailed sketch would be helpful.

3. Do not designate quantity by "set". State specifically how many parts are wanted.
4. Always give complete address and full shipping instructions. Specify shipping instructions, truck freight, air freight. United Parcel Service (UPS), or Air Borne Express and DHL are available in designated areas.

5. TO ORDER**A. BY MAIL**

Attention: Parts Department
REED
13822 Oaks Avenue
Chino, CA. 91710 - 7008

B. BY FAX

(909) 287 - 2141

C. BY PHONE

(909) 287 - 2100

6. Parts return without authorization will not be accepted. If it is necessary to return parts for any reason, written authorization may be obtained from **REED** Parts Department, Chino, CA. 91710-7008. A Parts Return Authorization form is provided when **REED** deems its necessary to have the part returned for evaluation. The form is issued by the Warranty of Parts Department of **REED**.
 - A. The form will be filled by **REED** unless requesting necessary information and you will receive a copy as well as shipping tag.
 - B. Attach shipping tag to part insert return original invoice.
 - C. Ship part to **REED PREPAID**.
 - D. Part must be returned to **REED** within 30 days from date of authorization.



REED TRUCK MOUNTED CONCRETE BOOM PUMP MODEL **XXT 42**
ILLUSTRATED PARTS MANUAL GROUP 10 FINAL INSTALLATION CONTAINS
THE FOLLOWING FIGURES:

- FIGURE 00** TABLE OF CONTENTS
- FIGURE 01** FINAL INSTALLATION
- FIGURE 02** DECAL ASSEMBLY

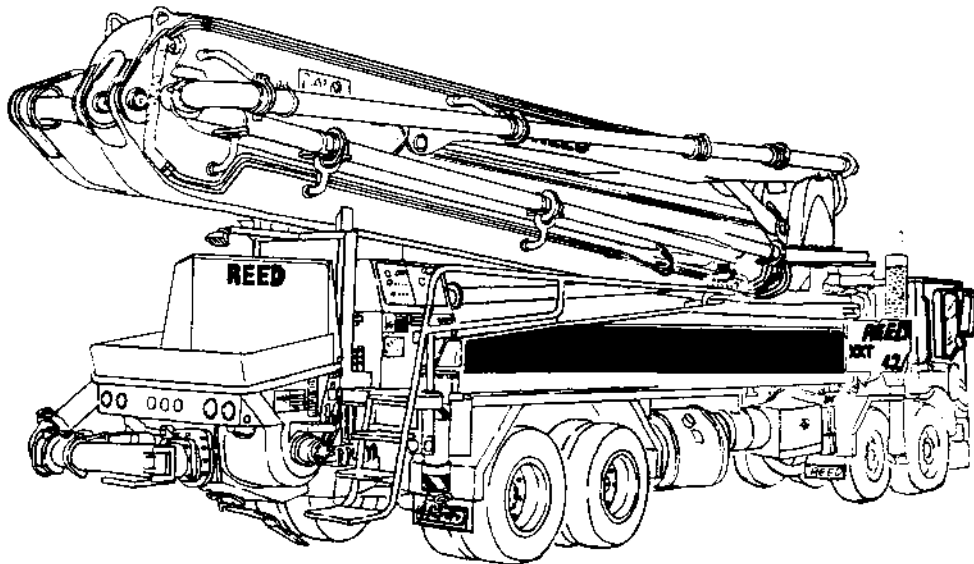

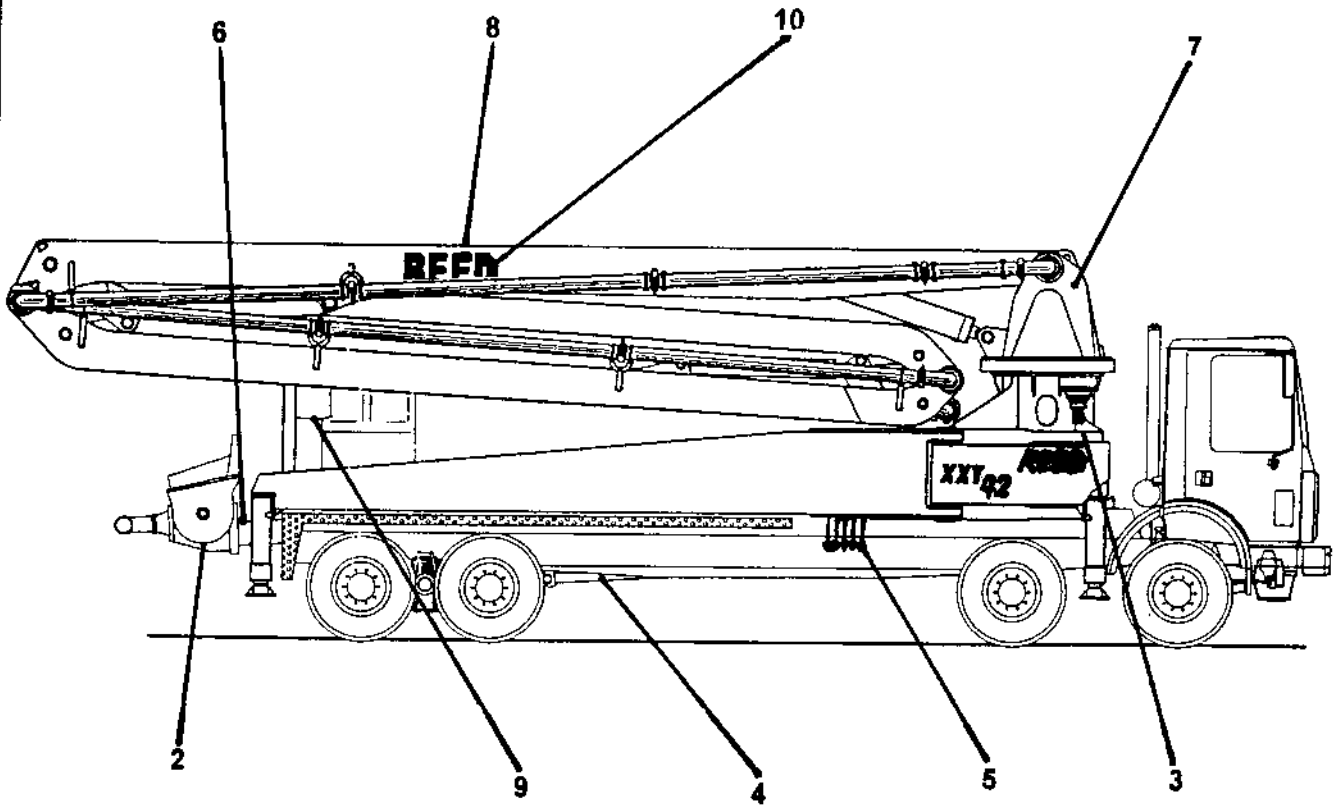

ITEM NO.	REED'S PARTS NO.	DESCRIPTION					QTY
		1	2	3	4	5	
-1	800523	Installation, XXT 42 Final					Ref
2	20-01	• Installation, Hopper (See Group 20, Figure 01 for DET)					1
3	30-01	• Installation, Tank (See Group 30, Figure 01 for DET)					1
4	40-01	• Installation, Power Train (See Group 40, Figure 01 for DET)					1
5	50-01	• Installation, Control (See Group 50, Figure 01 for DET)					1
6	60-01	• Installation, Pumping Train (See Group 60, Figure 01 for DET)					1
7	70-01	• Installation, Frame and Support (See Group 70, Figure 01 for DET)					1
8	80-01	• Installation, Optional (See Group 80, Figure 01 for DET)					1
9	90-01	• Installation, Boom (See Group 90, Figure 01 for DET)					1
10	10-02	• Assembly, Decal (See Group 10, Figure 02 for DET)					1

DASH (-) ITEM NOT ILLUSTRATED

REED

DECAL ASSEMBLY

XXT 42
PARTS
GROUP 10
FIGURE 02
PAGE 01

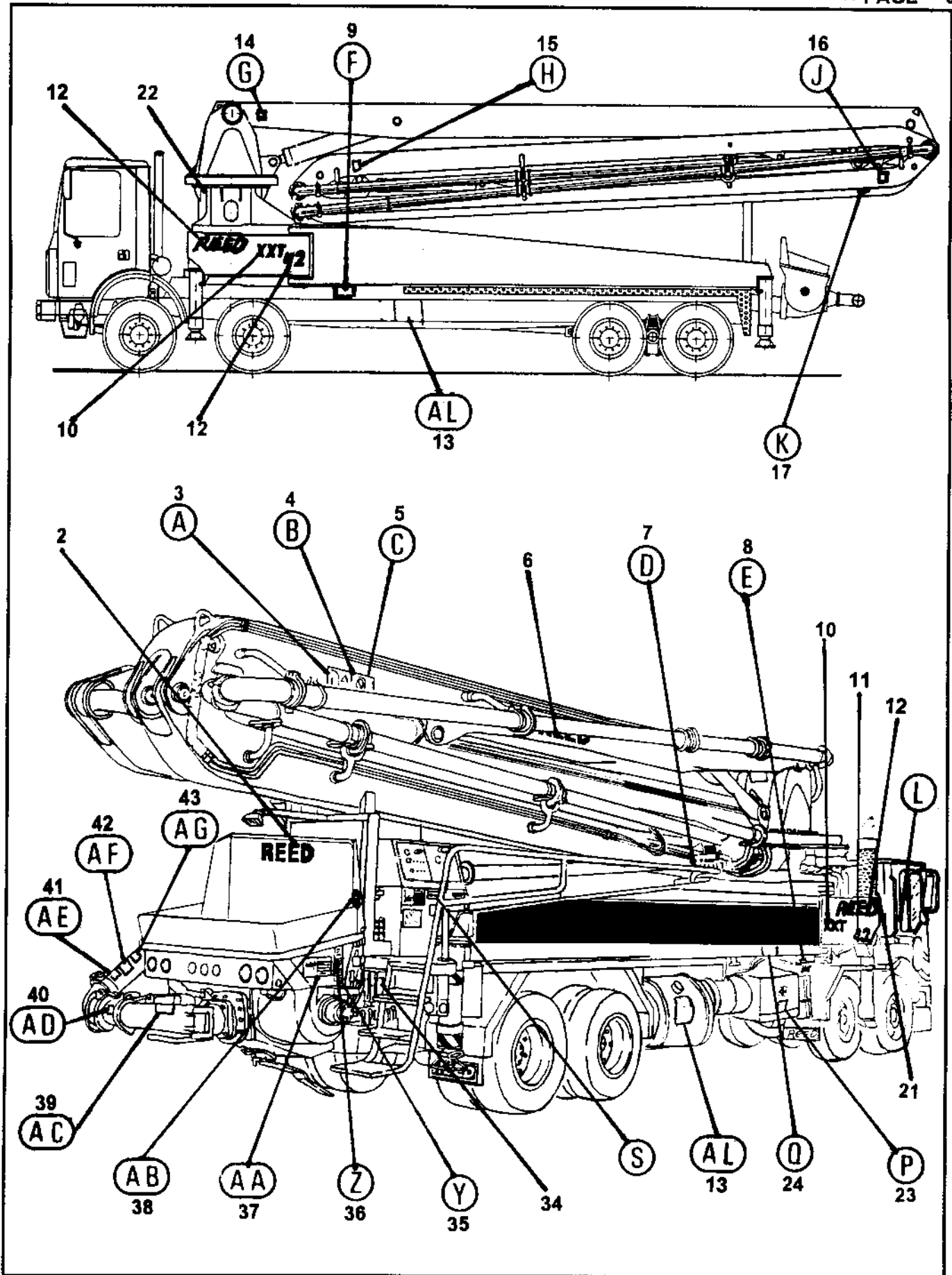

REVISION:

ITEM NO.	REED'S PARTS NO.	DESCRIPTION					QTY
		1	2	3	4	5	
-1	10-02	Assembly, Decal (See Group 10, Figure 01 for NHA)					Ref
2	800442	• Decal, REED , 6 Inch Black					1
3	C-4V107	• Plate, Danger Of Falling Object					1
4	C-4V106	• Plate, Never Use As Crane					1
5	C-4V105	• Plate, Death Hazard					1
6	801069	• Decal, REED , 12 Inch White					2
7	C-4V120	• Plate, Hydraulic Distributor					1
8	C-9V111	• Decal, Right Side Stabilizers					1
9	C-9V112	• Decal, Left Side Stabilizers					1
10		• Decal, XXT , 5 Inch Optional Color					2
11		• Decal, 32 , 8 Inch Optional Color					2
12		• Decal, REED , 8 Inch Optional Color					2
13	801441	• Decal, XXT Range					4
14	C-4V113	• Decal, A Letter Adhesive					1
15	C-4V115	• Decal, C Letter Adhesive					1
16	C-4V116	• Decal, D Letter Adhesive					1
17	C-4V114	• Decal, B Letter Adhesive					1
-18	800766	• Kit, XXT 42 Decal					1
19	800051	•• Nameplate, PTO					1
20	800059	•• Plate, PTO Operation					1
21	800034	•• Decal, Oil Level					2
22	800033	•• Decal, Water					1
23	800915	•• Decal, Danger, Stay Clear					3
24	800919	•• Decal, Warning, Stand Clear of Outriggers when activating					4
-25	800920	•• Decal, Warning, Clear Area Before Activating Outriggers					2
26	B-513013	•• Decal, Control Box Panel					1
27	801113	•• Decal, Gauge					1
28		•• Decal, A B					1
29	800926	•• Decal, Warning, Do Not Operate This Machine without					2
30	800929A	•• Decal, Warning					1
31	800925	•• Decal, Warning, Do Not Operate This Machine without					1
32	800930	•• Decal, ACPA Hand Signals					1
33	800913	•• Decal, Danger, Electrocution Hazard					1
34	800875	•• Nameplate, Agitator / Water					1
35	800918	•• Decal, Warning, Do Not Stand on Hopper Grate					2
36	800917	•• Decal, Warning, Keep Hand Out of Hopper and Valve					2
37	800924	•• Decal, Warning, This Machine is Remote Controlled and					1
38	800931	•• Decal, ACPA Member					1
39	800922	•• Decal, Warning, Before Opening a Blocked Pipeline,					1
40	800923	•• Decal, Warning, Use Retaining Pins in all Delivery					1
41	800928	•• Decal, Warning, Total Weight of all Hanging Hoses,					1
42	800927	•• Decal, Warning, Do Not Use the Boom as a Crane					1
43	800921	•• Decal, Warning, Do Not Operate at Pressures Exceeding					1
-44	800914	•• Decal, Danger, Electrocution Hazard					1
-45	800916	•• Decal, Warning, Keep Hand Out of Water Box					1
46	75009	•• Nameplate, REED , Serial No.					1

DASH (-) ITEM NOT ILLUSTRATED

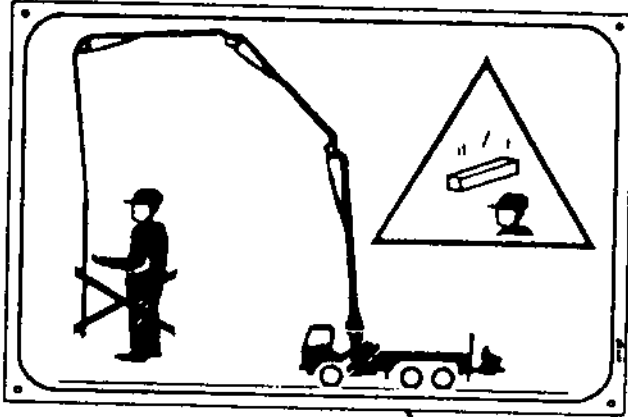

(A)

3

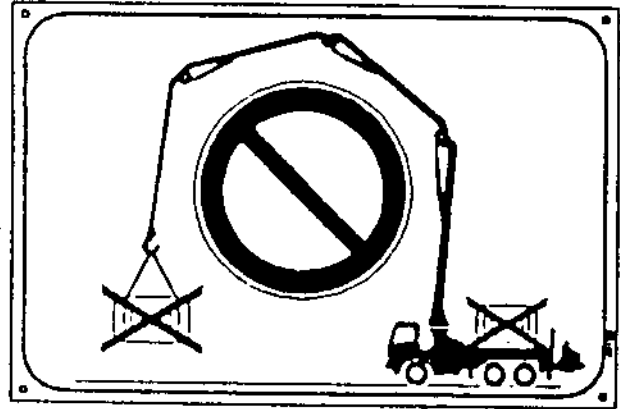

(B)

4

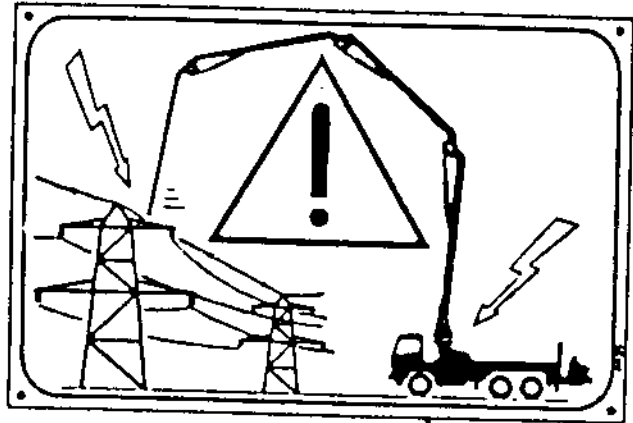

(C)

5

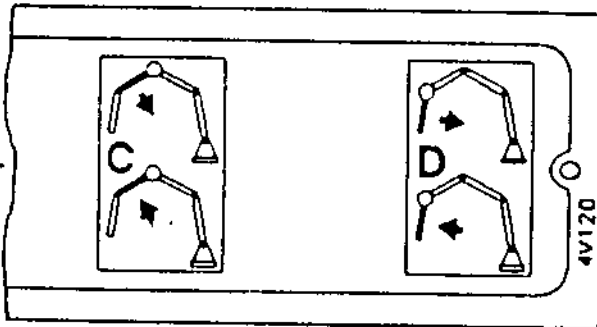

(D)

7

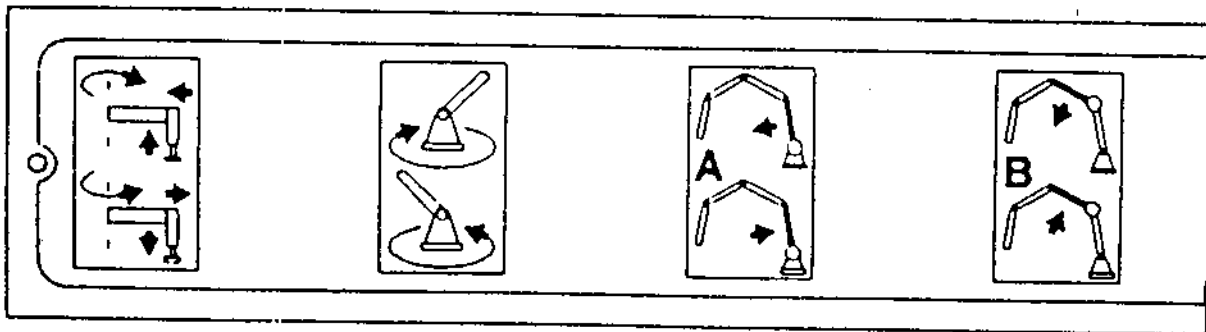

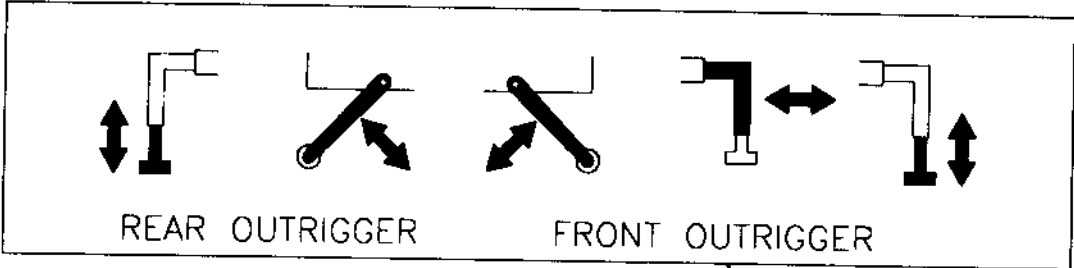

(E)

8

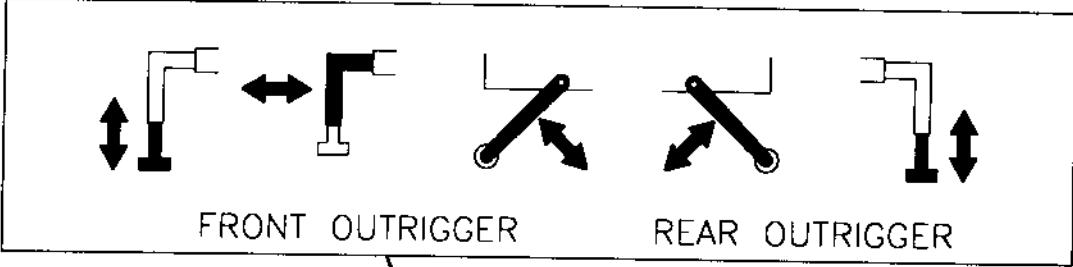

9

(F)

B

17

(K)

A

14

(G)

D

16

(J)

C

(H)

15

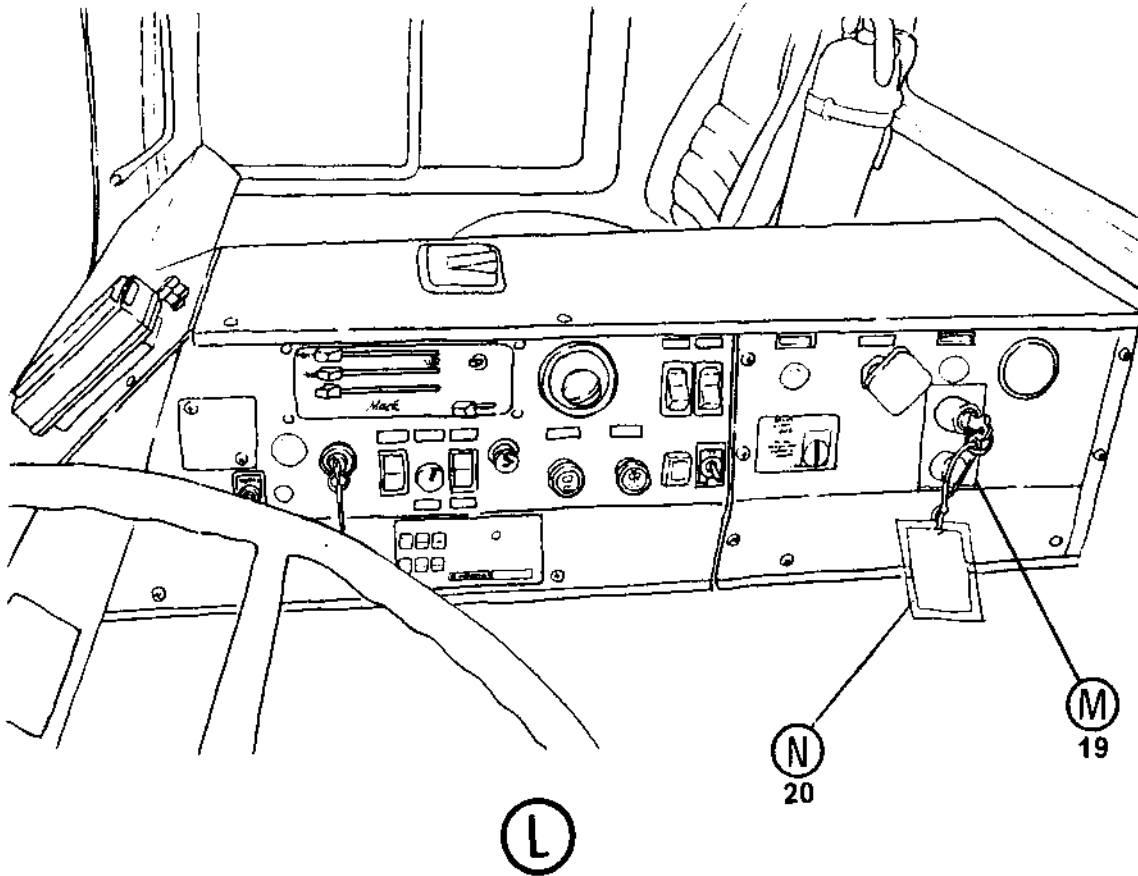

TO OPERATE PUMP AND BOOM

1. POSITION TRUCK AND SET PARKING BRAKE.
2. DEPRESS CLUTCH AND SHIFT TO 7TH GEAR HIGH.
3. TURN PTO ON.
4. RELEASE CLUTCH TO ENGAGE PUMPS.
5. SET THROTTLE AT 1600 RPM MAXIMUM.

TO RETURN TO DRIVING MODE

1. RETURN THROTTLE TO IDLE.
2. DEPRESS CLUTCH AND TURN PTO OFF.
3. SHIFT TO NEUTRAL AND RELEASE CLUTCH.

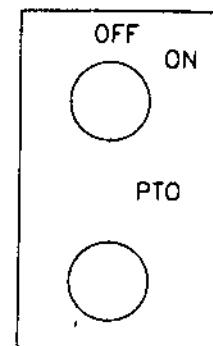

19

20



⚠ DANGER

Stay clear.
Contact will result in
death or serious injury
if the unit becomes
electrically charged.

800919

23

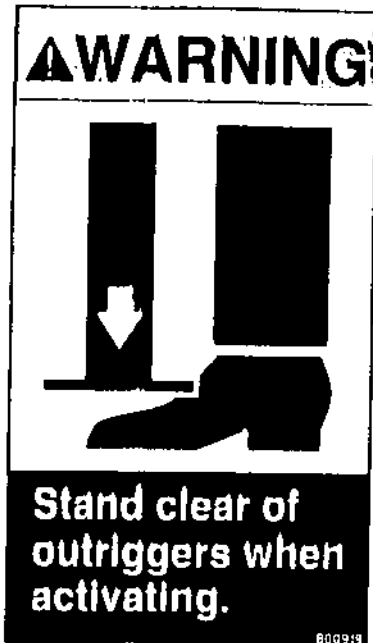

25

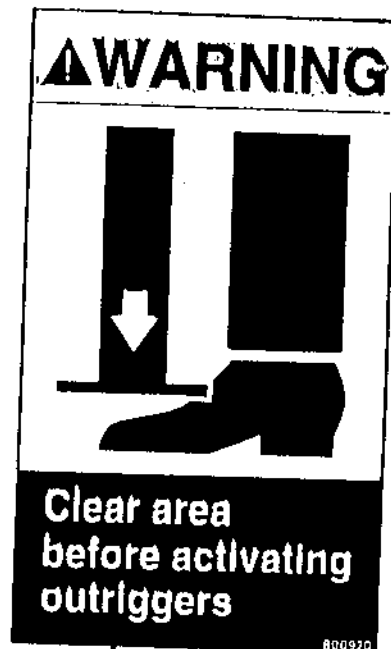

24



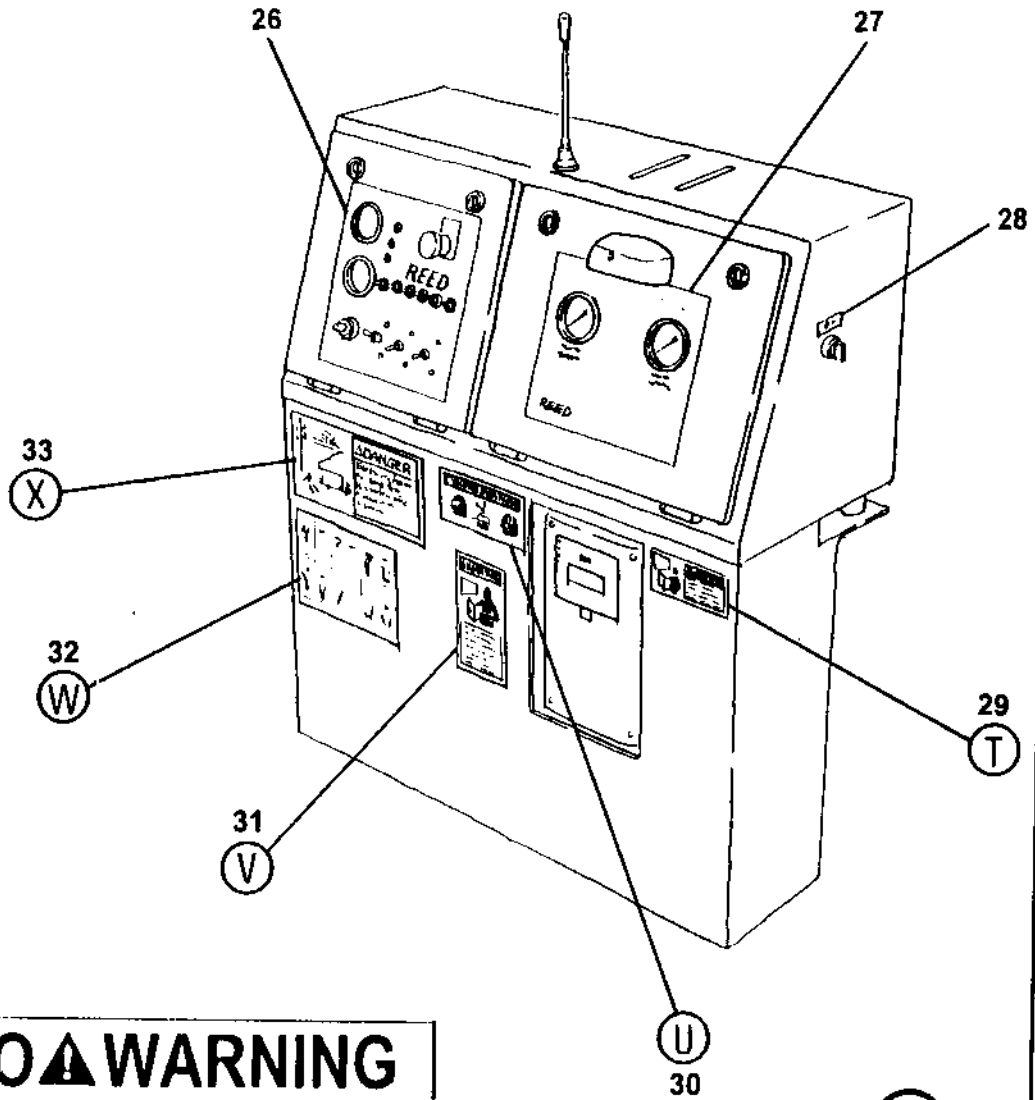

CUIDADO ⚠ WARNING

--	--	--

#00929

(U)

30

29

(T)

	<p>⚠ WARNING Do not operate this machine without training. Understand the warnings in safety manuals and on decals.</p>
--	--

#00929

▲ WARNING



Do not operate this machine without training. Understand the warnings in safety manuals and on decals.













000925

31



32



 1. BOOM UP	 2. BOOM DOWN	 3. BOOM LEFT	 4. BOOM RIGHT	 5. OPEN OR EXTEND BOOM	 6. CLOSE OR RETRACT BOOM	
 7. STOP BOOM	 8. START PUMP SPEED UP	 9. SLOW PUMP DOWN	 10. STOP PUMP	 11. LITTLE BIT	 12. ADD WATER 4-GALLONS	 13. ALL DONE CLEAN UP

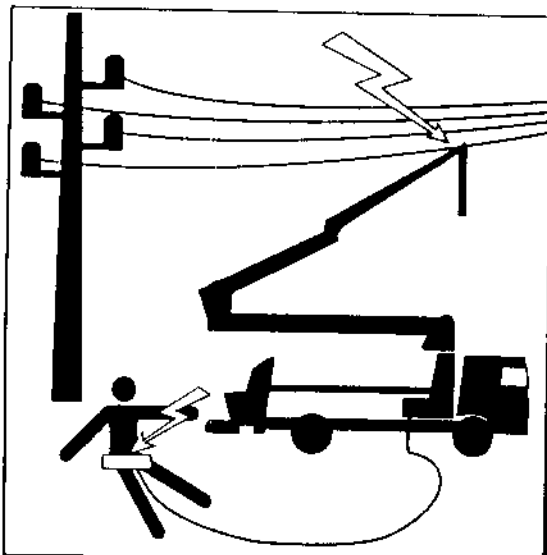

⚠ DANGER

Electrocution hazard.
Stay back from
high voltage wires
at least 17 feet
(5 meters).

800911

(X)

33

⚠ WARNING

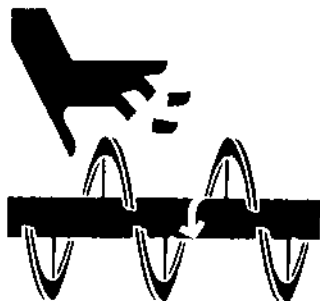

Keep hands out
of hopper and
valve assembly.
See operation
manual if access
is required.

800917

(Z)

36

⚠ WARNING



Do not stand on
hopper grates.

800918

(Y)

35

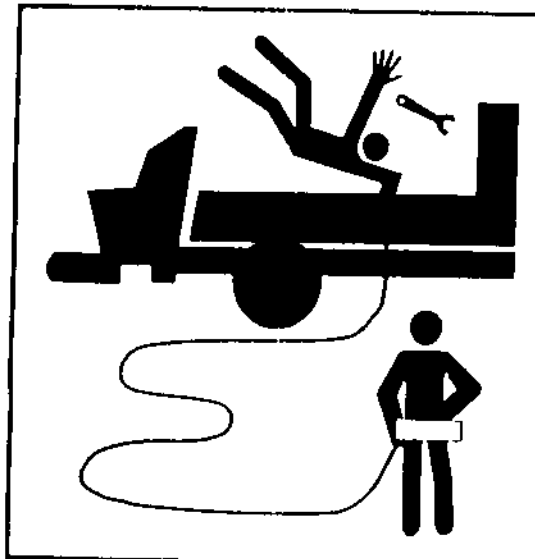

⚠ WARNING

This machine is remote controlled and may start at any time. Stop engine before servicing unit.

800924

AA

37

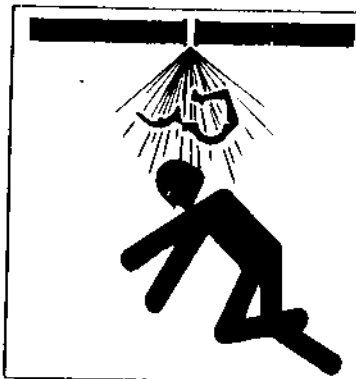

⚠ WARNING

Use retaining pins in all delivery system snap clamps.

800923

AD

40



38

AB

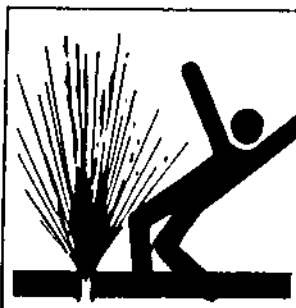

⚠ WARNING

Before opening a blocked pipeline, relieve pressure by reversing pump. See manual.

800922

AC

39

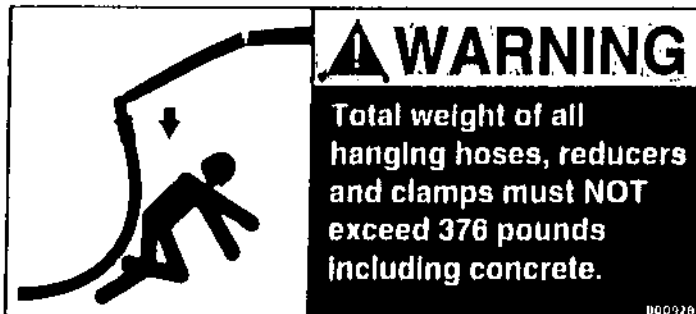

AE

41

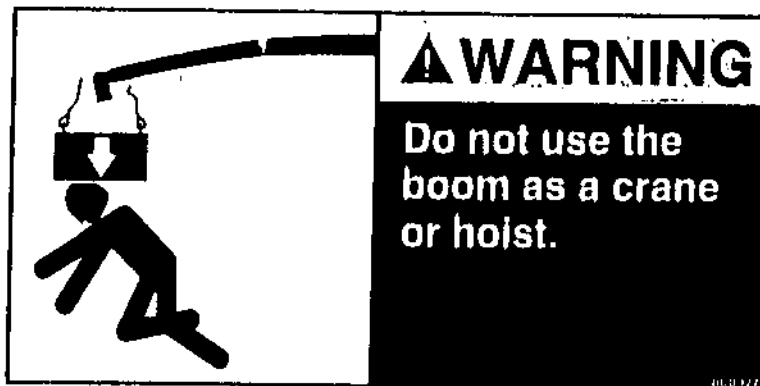

AF

42

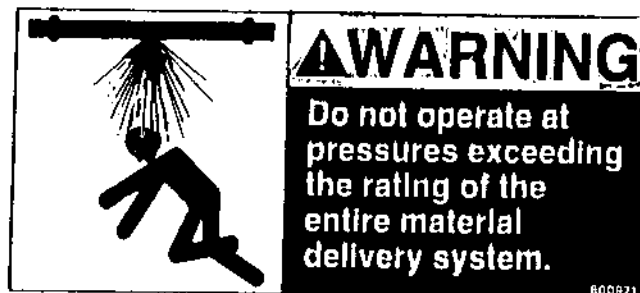

AG

43

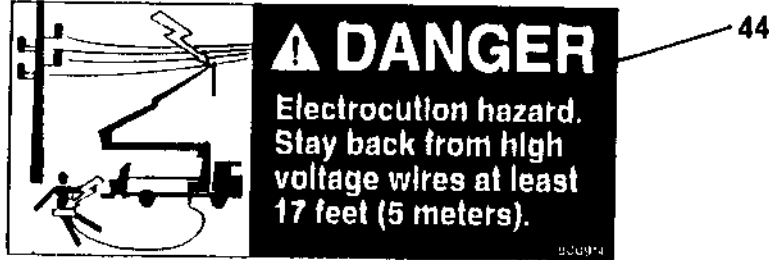

(AH)



(AJ)

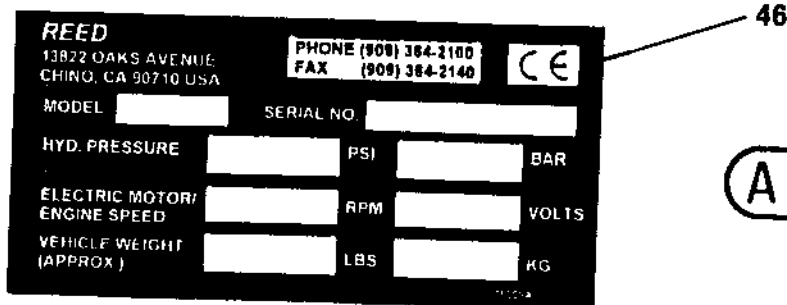

! WARNING

REED MODEL XXT42 DRAGONFLY

TYPICAL OPERATING CONFIGURATIONS

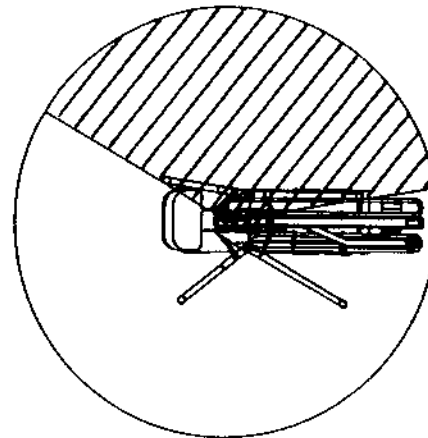
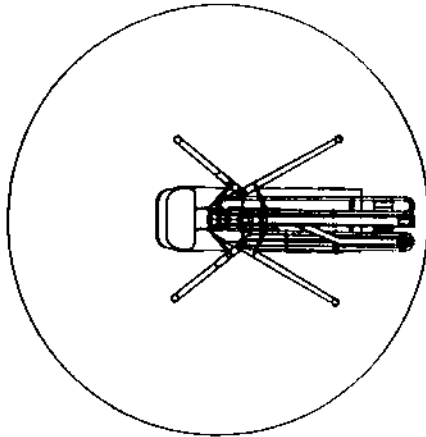
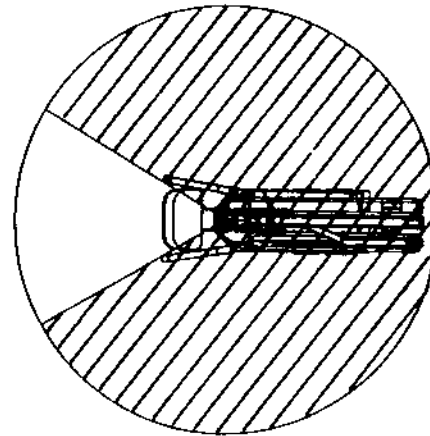
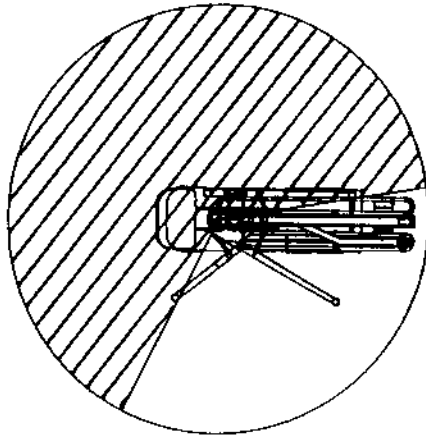

 NON-OPERATING AREA

Do not operate boom in this area due to danger of tipover.
Boom must be folded and vertical when rotating to operating area.

 OPERATING AREA

Outriggers must be fully extended and opened as shown.
All four outrigger jacks must be set on firm level ground.
Chassis must be level side to side and front to rear.

PN 801441

AL

13

ITEM NO.	REED'S PARTS NO.	DESCRIPTION					QTY
		1	2	3	4	5	
-1	10-02	Assembly, Decal (See Group 10, Figure 01 for NHA)					Ref
2	800442	• Decal, REED , 6 Inch Black					3
3	C-4V107	• Plate, Danger Of Falling Object					1
4	C-4V106	• Plate, Never Use As Crane					1
5	C-4V105	• Plate, Death Hazard					1
6	801069	• Decal, REED , 12 Inch White					2
7	C-4V120	• Plate, Hydraulic Distributor					1
8	C-9V111	• Decal, Right Side Stabilizers					1
9	C-9V112	• Decal, Left Side Stabilizers					1
10		• Decal, XXT , 5 Inch Optional Color					2
11		• Decal, 32 , 8 Inch Optional Color					2
12		• Decal, REED , 8 Inch Optional Color					2
13	801441	• Decal, XXT Range					4
14	C-4V113	• Decal, A Letter Adhesive					1
15	C-4V115	• Decal, C Letter Adhesive					1
16	C-4V116	• Decal, D Letter Adhesive					1
17	C-4V114	• Decal, B Letter Adhesive					1
-18	800766	• Kit, XXT 42 Decal					1
19	800051	•• Nameplate, PTO					1
20	800059	•• Plate, PTO Operation					1
21	800034	•• Decal, Oil Level					2
22	800033	•• Decal, Water					1
23	800915	•• Decal, Danger, Stay Clear					3
24	800919	•• Decal, Warning, Stand Clear of Outriggers when activating					4
-25	800920	•• Decal, Warning, Clear Area Before Activating Outriggers					2
26	B-513013	•• Decal, Control Box Panel					1
27	801113	•• Decal, Gauge					1
28		•• Decal, A B					1
29	800926	•• Decal, Warning, Do Not Operate This Machine without					2
30	800929A	•• Decal, Warning					1
31	800925	•• Decal, Warning, Do Not Operate This Machine without					1
32	800930	•• Decal, ACPA Hand Signals					1
33	800913	•• Decal, Danger, Electrocution Hazard					1
34	800875	•• Nameplate, Agitator / Water					1
35	800918	•• Decal, Warning, Do Not Stand on Hopper Grate					2
36	800917	•• Decal, Warning, Keep Hand Out of Hopper and Valve					2
37	800924	•• Decal, Warning, This Machine is Remote Controlled and					1
38	800931	•• Decal, ACPA Member					1
39	800922	•• Decal, Warning, Before Opening a Blocked Pipeline,					1
40	800923	•• Decal, Warning, Use Retaining Pins in all Delivery					1
41	800928	•• Decal, Warning, Total Weight of all Hanging Hoses,					1
42	800927	•• Decal, Warning, Do Not Use the Boom as a Crane					1
43	800921	•• Decal, Warning, Do Not Operate at Pressures Exceeding					1
-44	800914	•• Decal, Danger, Electrocution Hazard					1
-45	800916	•• Decal, Warning, Keep Hand Out of Water Box					1
46	75009	•• Nameplate, REED , Serial No.					1

DASH (-) ITEM NOT ILLUSTRATED



**MODEL XXT 42 TRUCK MOUNTED
CONCRETE BOOM PUMP
ILLUSTRATED PARTS MANUAL**

**XXT 42
PARTS
GROUP 10
FIGURE 03
PAGE 01**

THIS PAGE INTENTIONALLY LEFT BLANK.

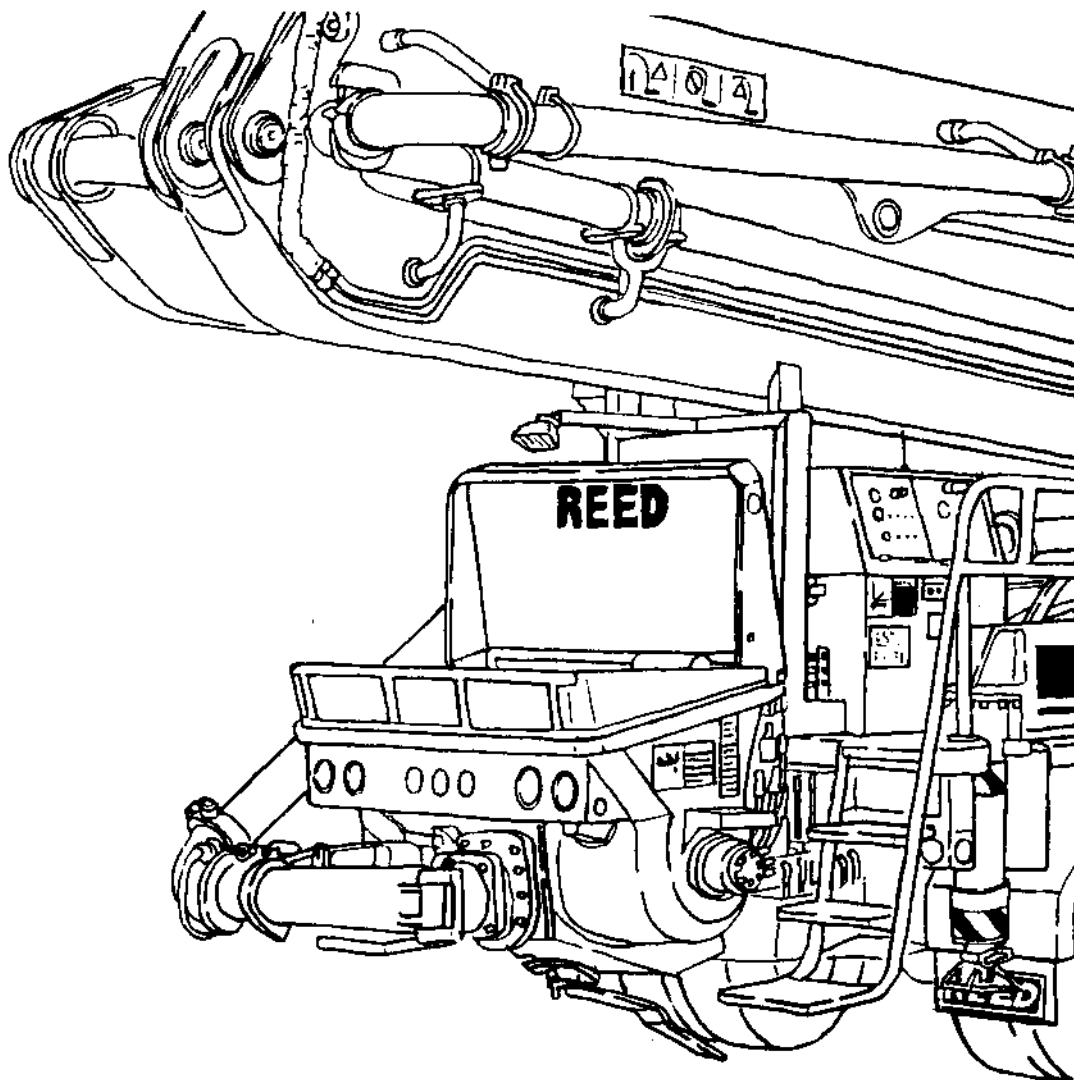

REED TRUCK MOUNTED CONCRETE BOOM PUMP MODEL XXT 42 ILLUSTRATED PARTS MANUAL GROUP 20 HOPPER INSTALLATION CONTAINS THE FOLLOWING FIGURES:

- | | |
|------------------|---|
| FIGURE 00 | TABLE OF CONTENTS |
| FIGURE 01 | HOPPER INSTALLATION |
| FIGURE 02 | HOPPER HOOK ASSEMBLY |
| FIGURE 03 | LUBRICATION PUMP ASSEMBLY |
| FIGURE 04 | HOPPER VIBRATION ASSEMBLY |
| FIGURE 05 | HOPPER GRID ASSEMBLY |
| FIGURE 06 | AGITATOR AND WASH CONTROL VALVE ASSEMBLY |
| FIGURE 07 | AGITATOR ASSEMBLY |
| FIGURE 08 | AGITATOR DRIVE MOTOR ASSEMBLY |
| FIGURE 09 | HOPPER OUTLET ASSEMBLY |
| FIGURE 10 | DRIVE CYLINDER LUBRICATION SYSTEM ASSEMBLY |
| FIGURE 11 | HOPPER LUBRICATION SYSTEM ASSEMBLY |
| FIGURE 12 | LUBRICATION DISTRIBUTOR ASSEMBLY |

REED

HOPPER INSTALLATION

XXT 42
PARTS
GROUP 20
FIGURE 01
PAGE 01

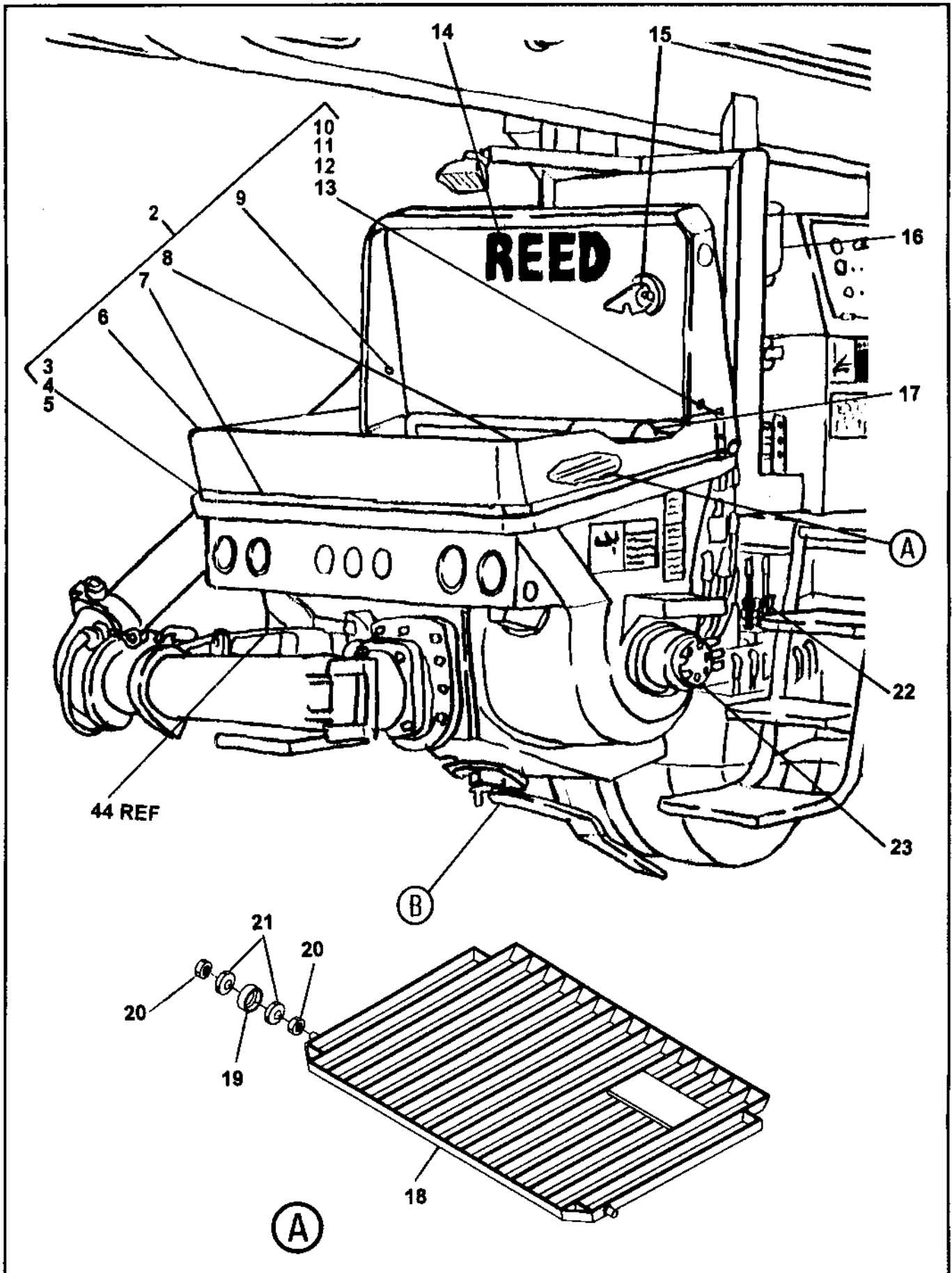

REVISION:

ITEM NO.	REED'S PARTS NO.	DESCRIPTION	QTY
-1	20-01	Installation, Hopper (See Group 10, Figure 01 for NHA)	Ref
2	B-224005	• Group, Splash Guard	1
3	W-103579	• • Screw, Flat	28
4	W-101627	• • Washer	28
5	W-101848	• • Nut, Cap	28
6	B-202007	• • Rubber Guard - Hopper	1
7	B-224014	• • Strip, Back Side	1
8	B-224015	• • Strip, Side	2
9	B-202009	• • Strip, Clamping	2
10	B-202004	• • Board, Splash	1
11	W-101621	• • Screw, Hex	11
12	W-101625	• • Washer	11
13	W-102111	• • Nut, Lock	11
14	800442	• Decal, REED Black 6 Inch	
15	B-224025	• Assembly, Hopper Hook (See Group 20, Figure 02 for DET)	1
16	800065	• Assembly, Central Lubrication Pump (See Group 20, Figure 03 for DET)	1
17	71429	• Assembly, Hopper Vibration (See Group 20, Figure 04 for DET)	1
18	B-224046	• Assembly, Hopper Grid (See Group 20, Figure 05 for DET)	1
19	W101849	• Buffer, Rubber	2
20	W-101559	• Washer	4
21	B-223011	• Nut, Cap	4
22	W-100124	• Assembly, Agitator/Wash Control Valve (See Group 20, Figure 06 for DET)	1
23	B-254120	• Assembly, Agitator (See Group 20, Figure 07 for DET)	1
-48	B-183005	• Assembly, Central Lubrication Pump System	1
-49	B-183006	• • Assembly, Drive Cylinder Lubrication System (See Group 20, Figure 10 for DET)	1
-50	B-183007	• • Assembly, Hopper Lubrication System (See Group 20, Figure 11 for DET)	1

DASH (-) ITEM NOT ILLUSTRATED

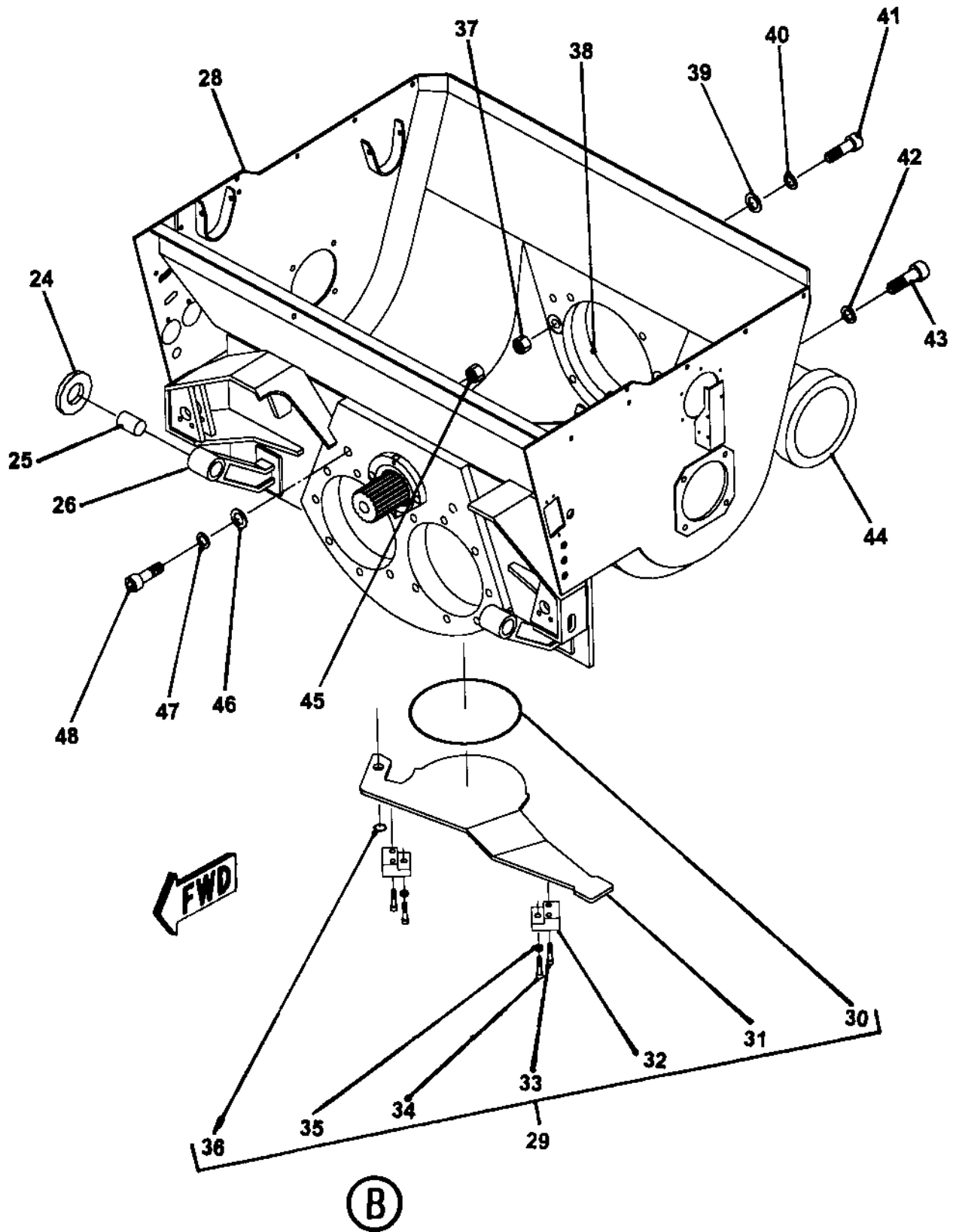

ITEM NO.	REED'S PARTS NO.	DESCRIPTION					QTY
		1	2	3	4	5	
24	W-114165	• Coupling, Holder					2
25	W-100940	• Pin					4
26	W-103411	• Washer					4
-27	B-114153	• Coupling, Bracket					2
28	B-173021	• Weldment, Hopper					1
29	B-173085	• Assembly, Cleaning Cover					1
30	W-102908A	• • O-Ring, Round Cord					1
31	B-172130	• • Cover, Cleaning					1
32	B-172126	• • Block, Clamping					2
33	W-102855	• • Screw, M20 (attaching parts)					4
34	B-172218	• • Screw, M20 (attaching parts)					2
35	W-102891	• • Nut, Hex M20 (attaching parts)					2
36	W-102864	• • Ring, Lock					1
37	W-102851	• Nut					2
38	B-174077	• Bracket, Rear					1
39	W-103298	• Washer					2
40	W-101786	• Washer, Spring					2
41	W-102853	• Screw, M24 Hex					2
42	W-100506	• Washer, Conical Spring					9
43	W-103282	• Bolt, M16 Hex					9
44	20-08	• Assembly, Hopper Outlet (See Group 20, Figure 08 for DET)					1
45	W-101555	• Nut					2
46	W-102893	• Washer					2
47	W-102072	• Washer, Spring					2
48	W-105047	• Bolt, M16 Cup Square Neck					2
-48	B-183005	• Assembly, Central Lubrication Pump System					1
-49	B-183006	• • Assembly, Drive Cylinder Lubrication System (See Group 20, Figure 10 for DET)					1
-50	B-183007	• • Assembly, Hopper Lubrication System (See Group 20, Figure 11 for DET)					1

DASH (-) ITEM NOT ILLUSTRATED

HOPPER HOOK ASSEMBLY

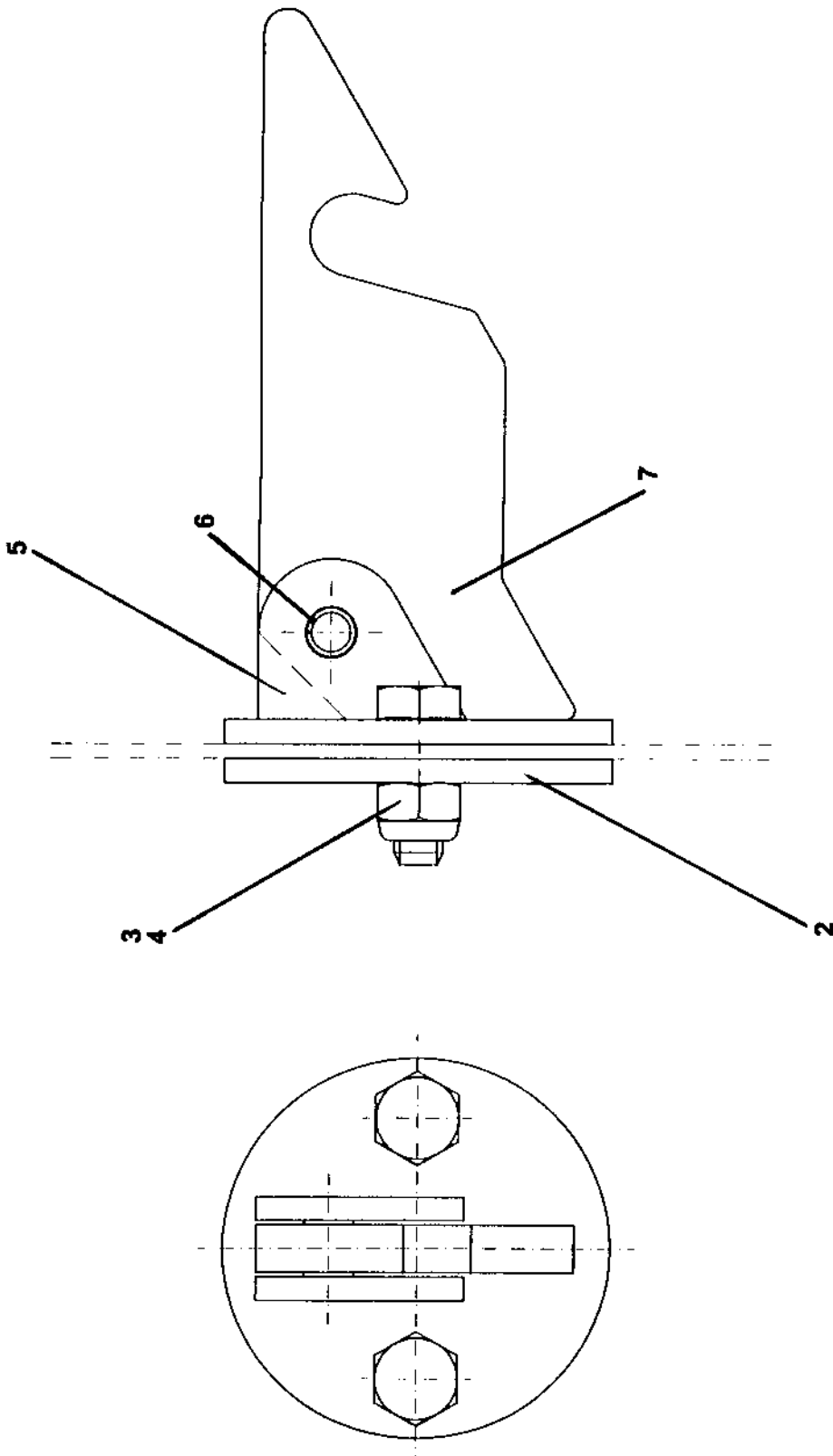



HOPPER HOOK ASSEMBLY

XXT 42
PARTS
GROUP 20
FIGURE 02
PAGE 02

ITEM NO.	REED'S PARTS NO.	DESCRIPTION					QTY
		1	2	3	4	5	
-1	B-224025	Assembly, Hopper Hook (See Group 20, Figure 01 for NHA)					Ref
2	B-224027	• Plate					1
3	W-101556	• Nut, M10					2
4	W-101553	• Bolt, Hex					2
5	B-224026	• Plate, Basic					1
6	W-102881	• Sleeve, Clamping					1
7	B-224030	• Plate					1

DASH (-) ITEM NOT ILLUSTRATED

REED

LUBRICATION PUMP ASSEMBLY

XXT 42
PARTS
GROUP 20
FIGURE 03
PAGE 01

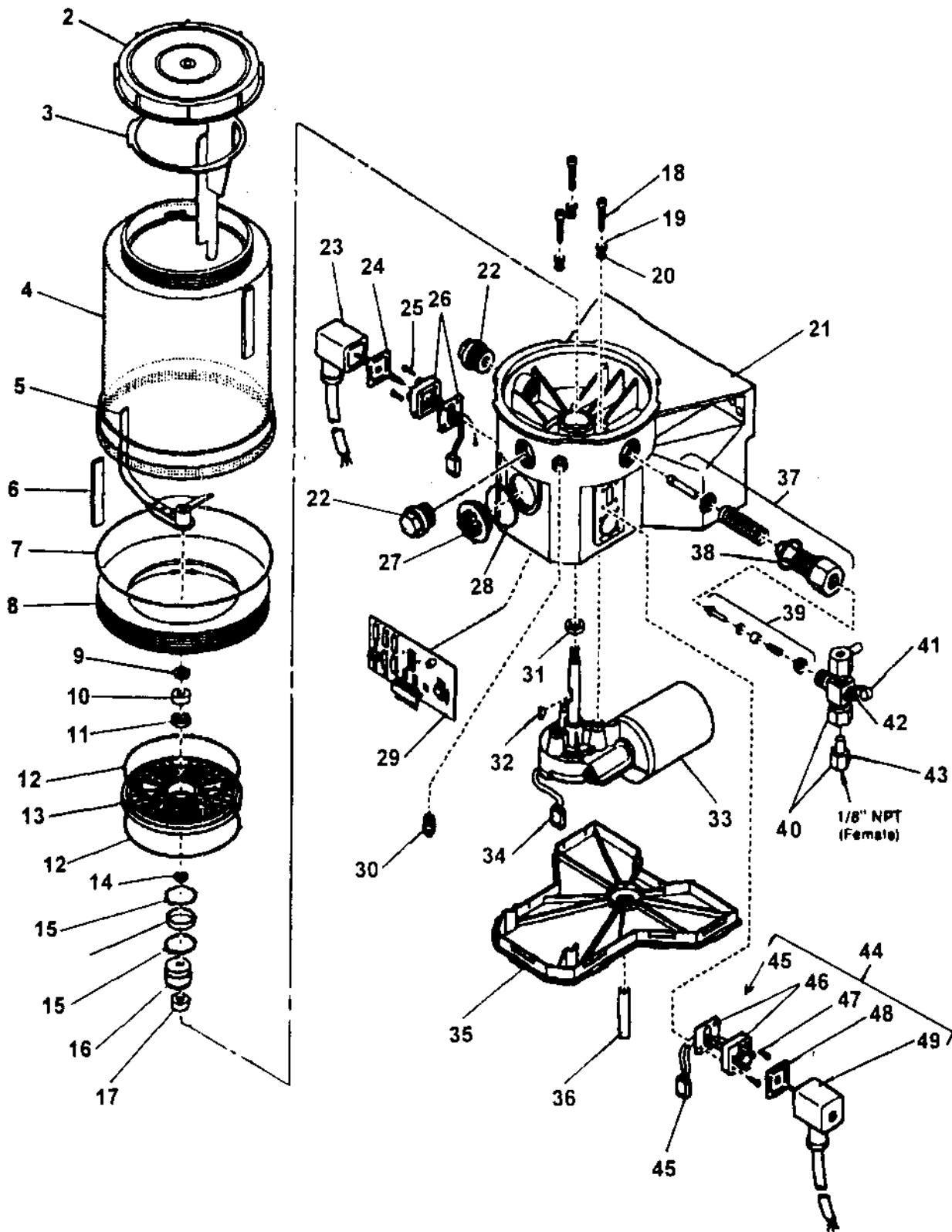

ITEM NO.	REED'S PARTS NO.	DESCRIPTION					QTY
		1	2	3	4	5	
-1	800065	Assembly, Lubrication Pump (See Group 20, Figure 01 for NHA)					Ref
2		• Lid					1
3		• Paddle, Fixed					1
4		• Reservoir					1
5		• Paddle, Stirring					1
6		• Hose					1
7		• O-Ring					1
8		• Adapter					1
9		• Washer					1
10		• Ring, Bearing					2
11		• Bearing					1
12		• O-Ring					2
13		• Plate, Intermediate					1
14		• Shim					1
15		• Ring, Snap					2
16		• Ring, Inner					1
17		• Cam, Eccentric					1
18		• Screw					3
19		• Washer					3
20		• O-Ring					3
21		• Housing, Pump					1
22		• Plug, Closure					2
23		• Socket with Cord					1
24		• Packing, Flat					1
25		• Screw					4
26		• Plug					1
27		• Plug, Sealing					1
28		• O-Ring					1
29		• Board, Printed Circuit					1
30		• Fitting, Grease					1
31		• Seal, Radial					1
32		• Key, Wood Ruff					1
33		• Motor, 12 VDC					1
34		• Plug, Motor					1
35		• Cover, Housing					1

DASH (-) ITEM NOT ILLUSTRATED

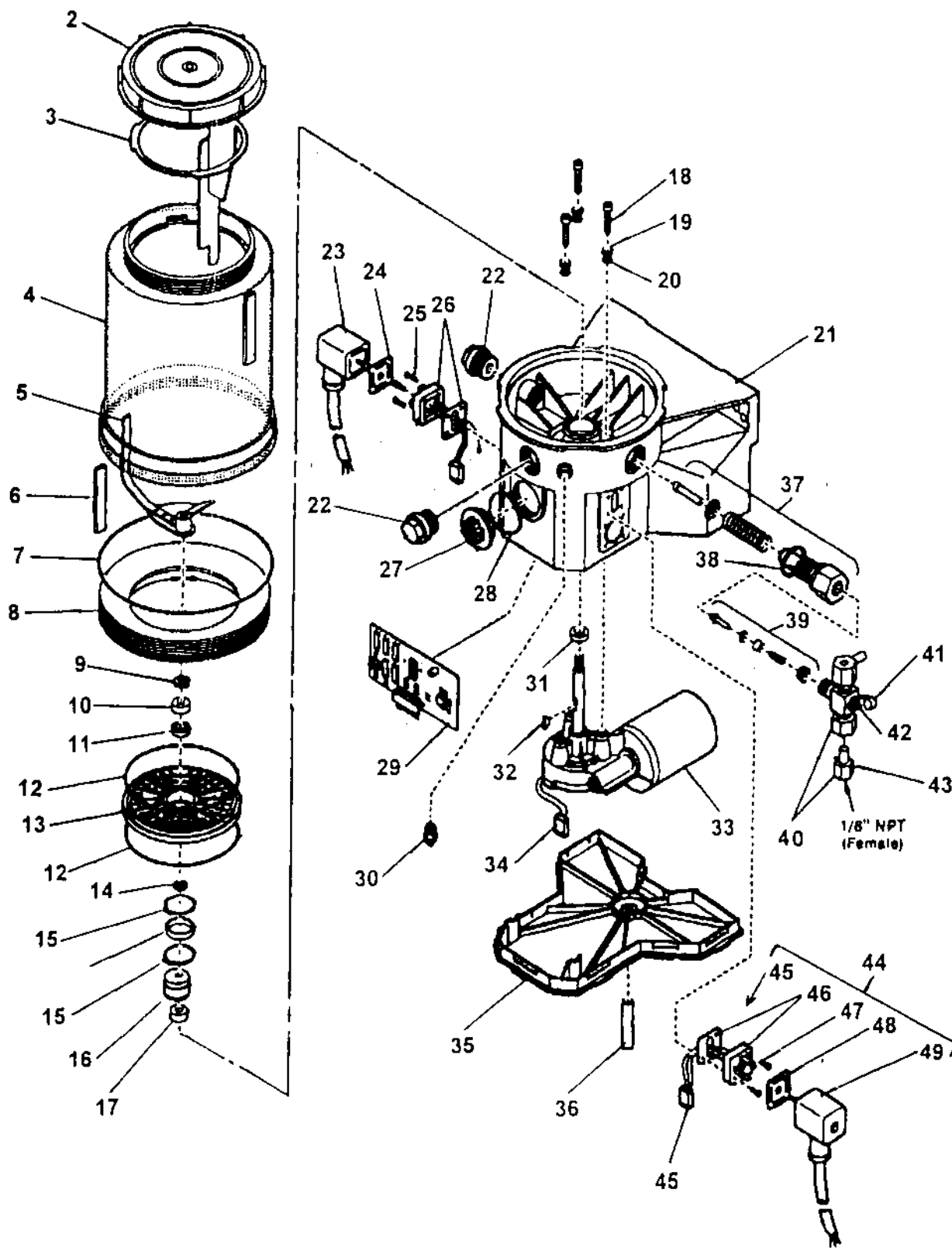



LUBRICATION PUMP ASSEMBLY

XXT 42
PARTS
GROUP 20
FIGURE 03
PAGE 04

ITEM NO.	REED'S PARTS NO.	DESCRIPTION					QTY
		1	2	3	4	5	
36					• Hose	1	
37					• Element, Pump	1	
38					• Gasket	1	
39					• Valve, Check	1	
40					• Assembly, Pressure Release	1	
41					• Cap, Grease	1	
42					• Fitting, Grease	1	
43					• Adapter for Relief	1	
44					• Assembly, Optional Pressure Relief Valve	1	
45					• • Cord, Optional Power	1	
46					• • Plug, Optional	1	
47					• • Screw, Optional	4	
48					• • Packing, Optional Flat	1	
49					• • Socket, Optional	1	

DASH (-) ITEM NOT ILLUSTRATED

REED

HOPPER VIBRATOR ASSEMBLY

XXT 42
PARTS
GROUP 20
FIGURE 04
PAGE 01

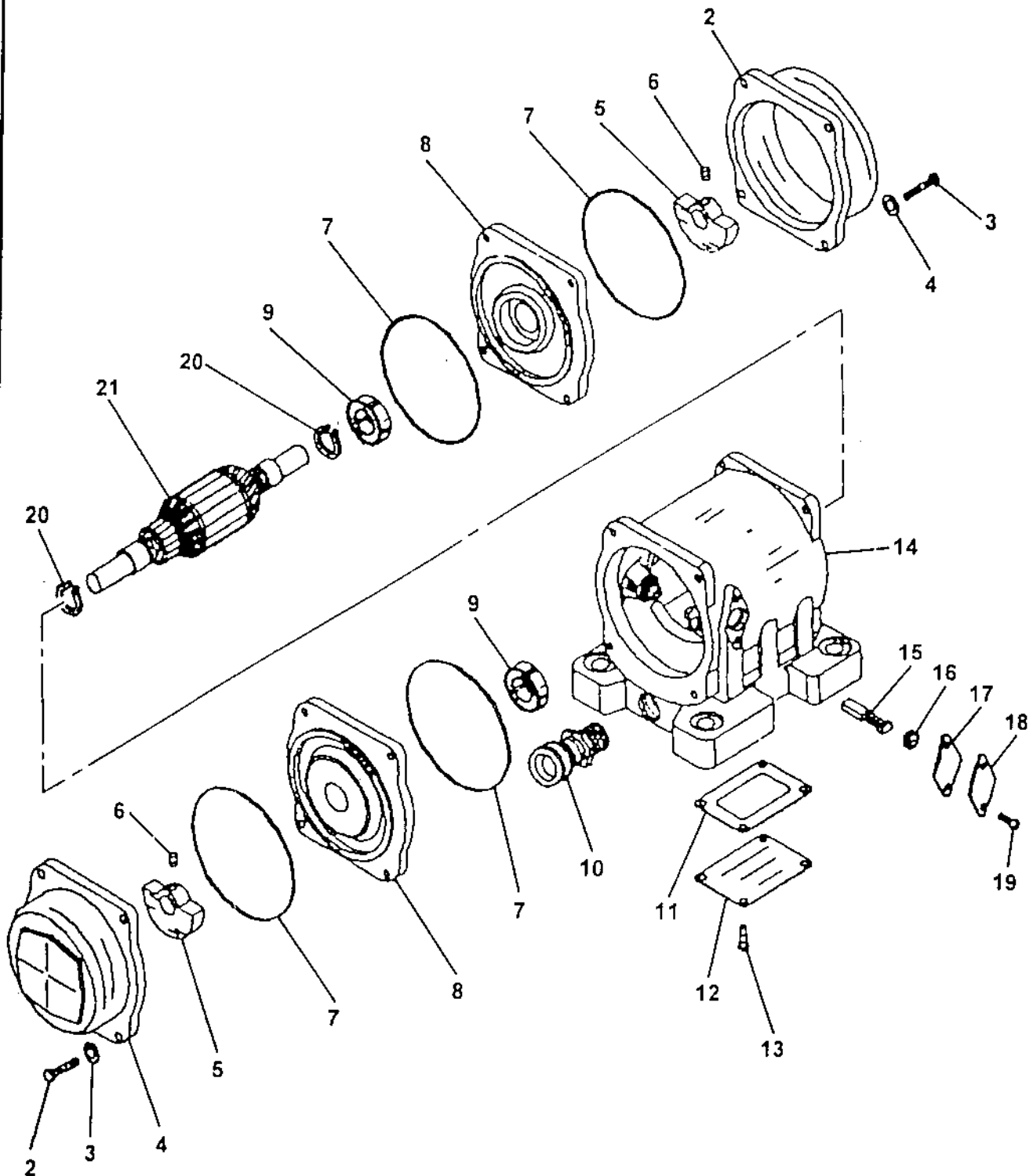

REVISION:

REED**HOPPER VIBRATOR ASSEMBLY****XXT 42**
PARTS
GROUP 20
FIGURE 04
PAGE 02

ITEM NO.	REED'S PARTS NO.	DESCRIPTION					QTY
		1	2	3	4	5	
-1	71429	Assembly, Hopper Vibrator (See Group 20, Figure 01 for NHA)					Ref
2		• Cap, End					2
3		• Bolt (attaching parts)					8
4		• Washer, Lock (attaching parts)					8
5		• Weight					2
6		• Screw, Set (attaching parts)					2
7		• O-Ring					4
8		• Bell, End					2
9		• Bearing					2
10		• Holder, Cord					1
11		• Gasket					1
12		• Cover, Box					1
13		• Screw (attaching parts)					4
14		• Sub-Assembly, Housing					1
15		• Brush					1
16		• Cap, Brush					2
17		• Gasket					2
18		• Cover, Brush					2
19		• Screw (attaching parts)					4
20		• Ring, Snap					2
21		• Assembly, Armature					1

DASH (-) ITEM NOT ILLUSTRATED



HOPPER GRID ASSEMBLY

XXT 42
PARTS
GROUP 20
FIGURE 05
PAGE 01

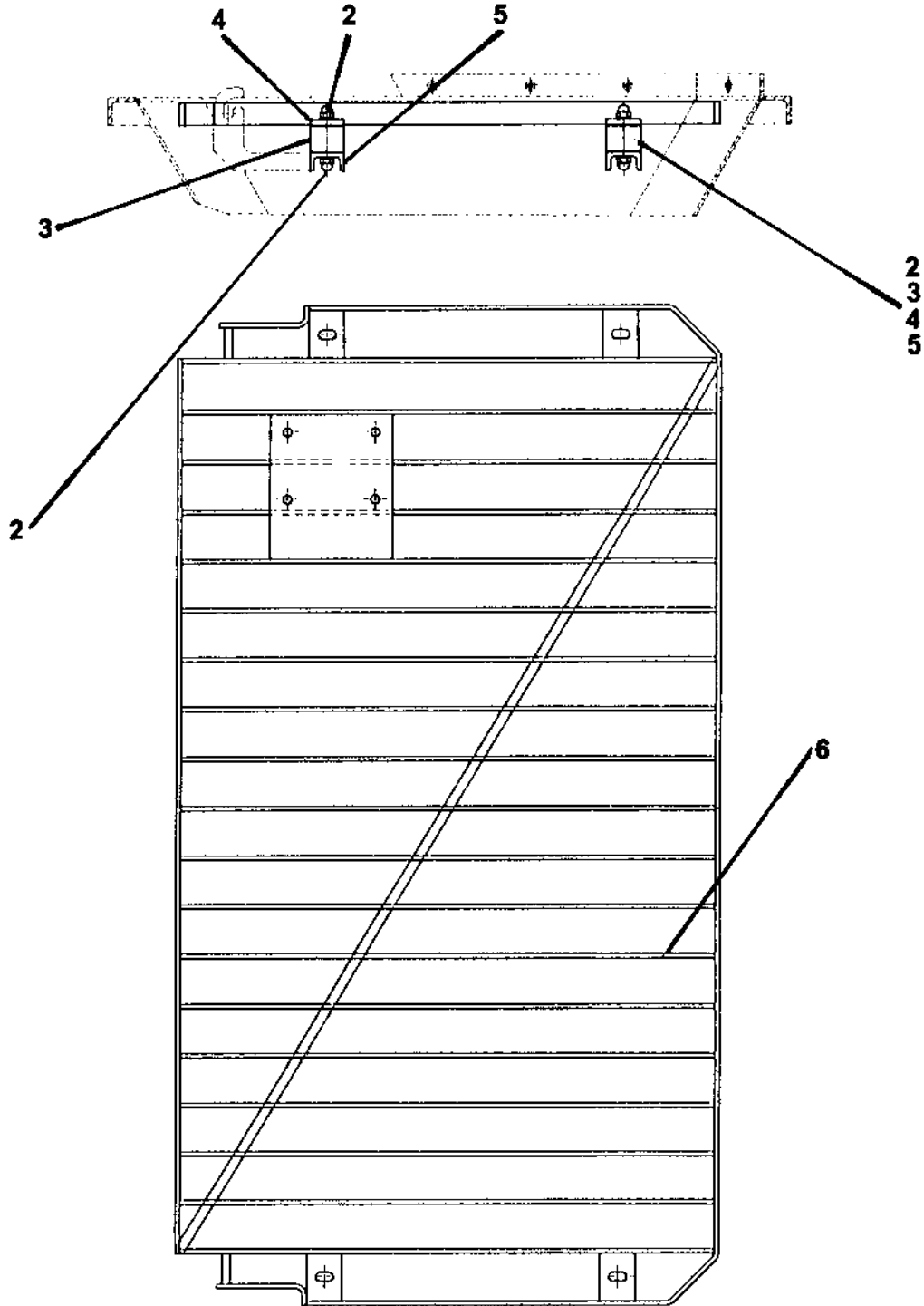



HOPPER GRID ASSEMBLY

XXT 42
PARTS
GROUP 20
FIGURE 05
PAGE 02

ITEM NO.	REED'S PARTS NO.	DESCRIPTION					QTY
		1	2	3	4	5	
-1	B-224046	Assembly, Hopper Grid (See Group 20, Figure 01 for NHA)					Ref
2	B-101847	• Nut, Cap					8
3	W-104067	• Cushion, Lover					4
4	W-103288	• Washer					4
5	W-103288	• Plate, Basic					4
6	B-224035	• Weldment, Grid					1

DASH (-) ITEM NOT ILLUSTRATED

AGITATOR AND WASH CONTROL VALVE ASSEMBLY

XXT 42
PARTS
GROUP 20
FIGURE 06
PAGE 01

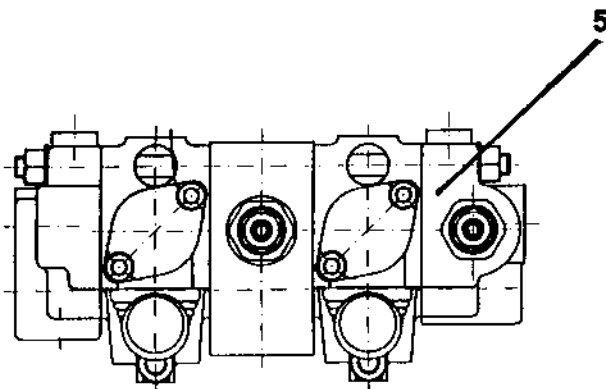
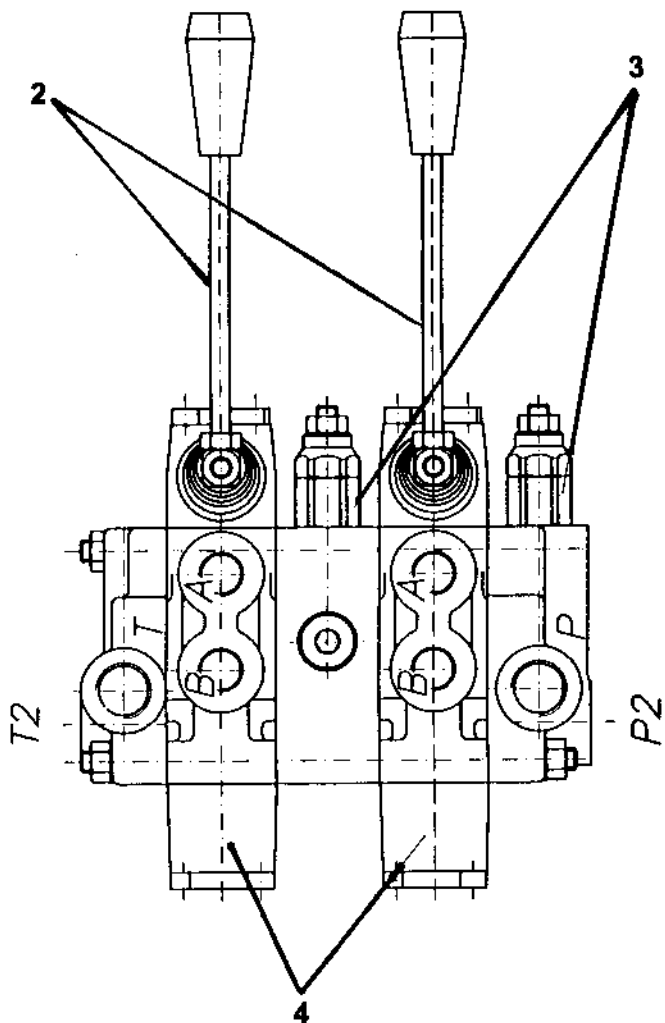



**AGITATOR AND WASH CONTROL
VALVE ASSEMBLY**

XXT42
PARTS
GROUP 20
FIGURE 06
PAGE 02

ITEM NO.	REED'S PARTS NO.	DESCRIPTION					QTY
		1	2	3	4	5	
-1	W-100124	Assembly, Agitator and Wash Control Valve (See Group 20, Figure 01 for NHA)					Ref
2	W-102747	• Lever, Control Valve					2
3	W-105559	• Cartridge, Control Valve					2
4	W-105644	• Element					2
5	W-101881	• Kit, seal					4

DASH (-) ITEM NOT ILLUSTRATED

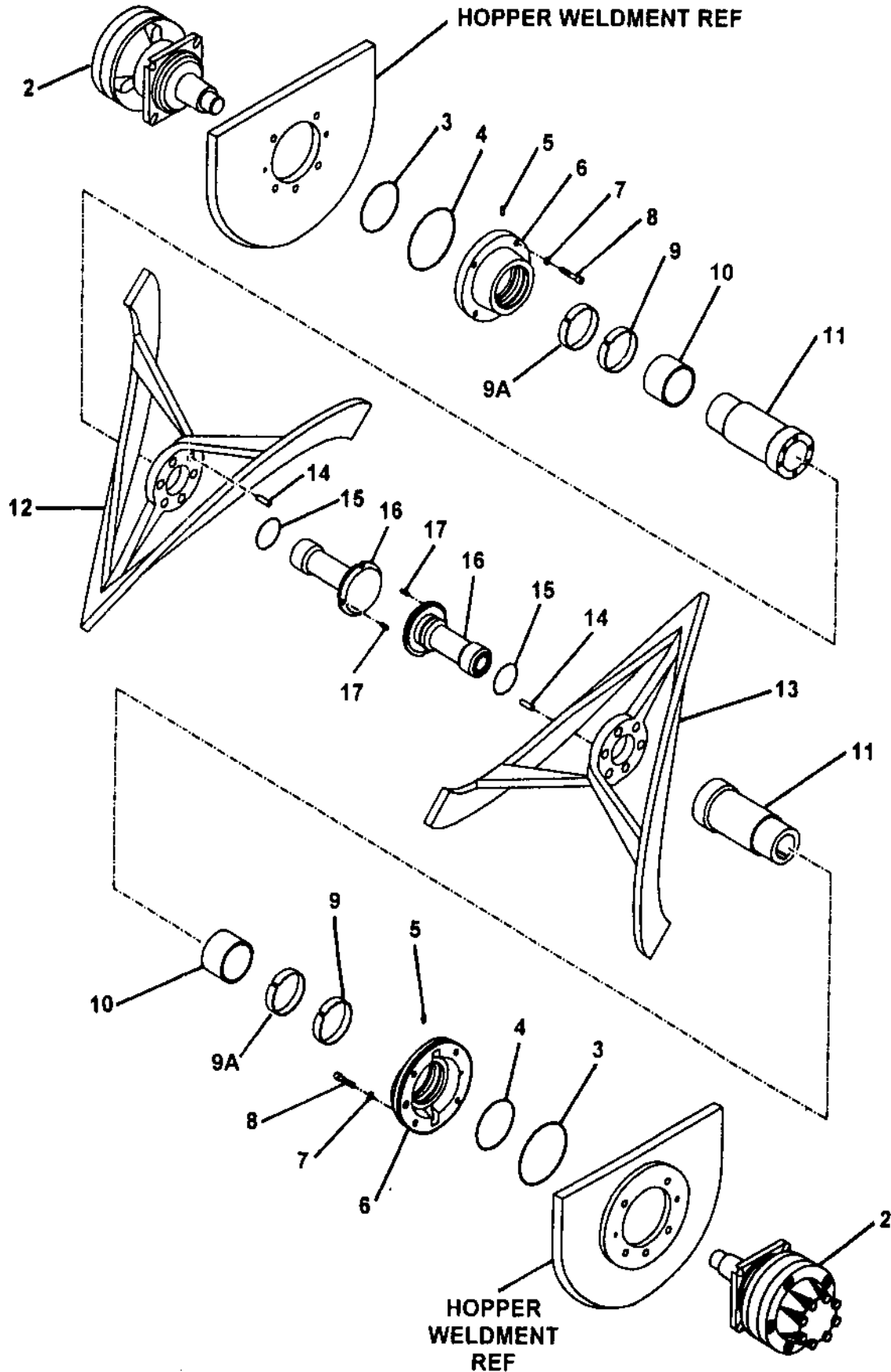



AGITATOR ASSEMBLY

XXT42
PARTS
GROUP 20
FIGURE 07
PAGE 02

ITEM NO.	REED'S PARTS NO.	DESCRIPTION					QTY
		1	2	3	4	5	
-1	B-254120	Assembly, Agitator (See Group 20, Figure 01 for NHA)					Ref
2	W-101240	• Assembly, Agitator Drive Motor (See Group 20, Figure 08 for DET)					1
3	W-103064	• O-Ring					2
4	W-103063	• O-Ring					2
5	W-1004909	• Screw, M5 Set					2
6	B-254101	• Assembly, Flange					2
7	W-102962	• Washer					8
8	W-103062	• Screw, M12 Hex					8
9	W-102544	• Ring, Groove-Outer					2
9A	B-253029	• Ring, Groove-Inner					2
10	B-254104	• Sleeve, Wear					2
11	B-254102	• Shaft					2
12	B-254105	• Agitator, Left					1
13	B-254106	• Agitator, Right					1
14	W-103065	• Pin 10m					12
15	W-103249	• O-Ring					2
16	B-254103	• Nut					2
17	W-103106	• Sleeve, Clamping					4

DASH (-) ITEM NOT ILLUSTRATED



AGITATOR DRIVE MOTOR ASSEMBLY

XXT 42
PARTS
GROUP 20
FIGURE 08
PAGE 01

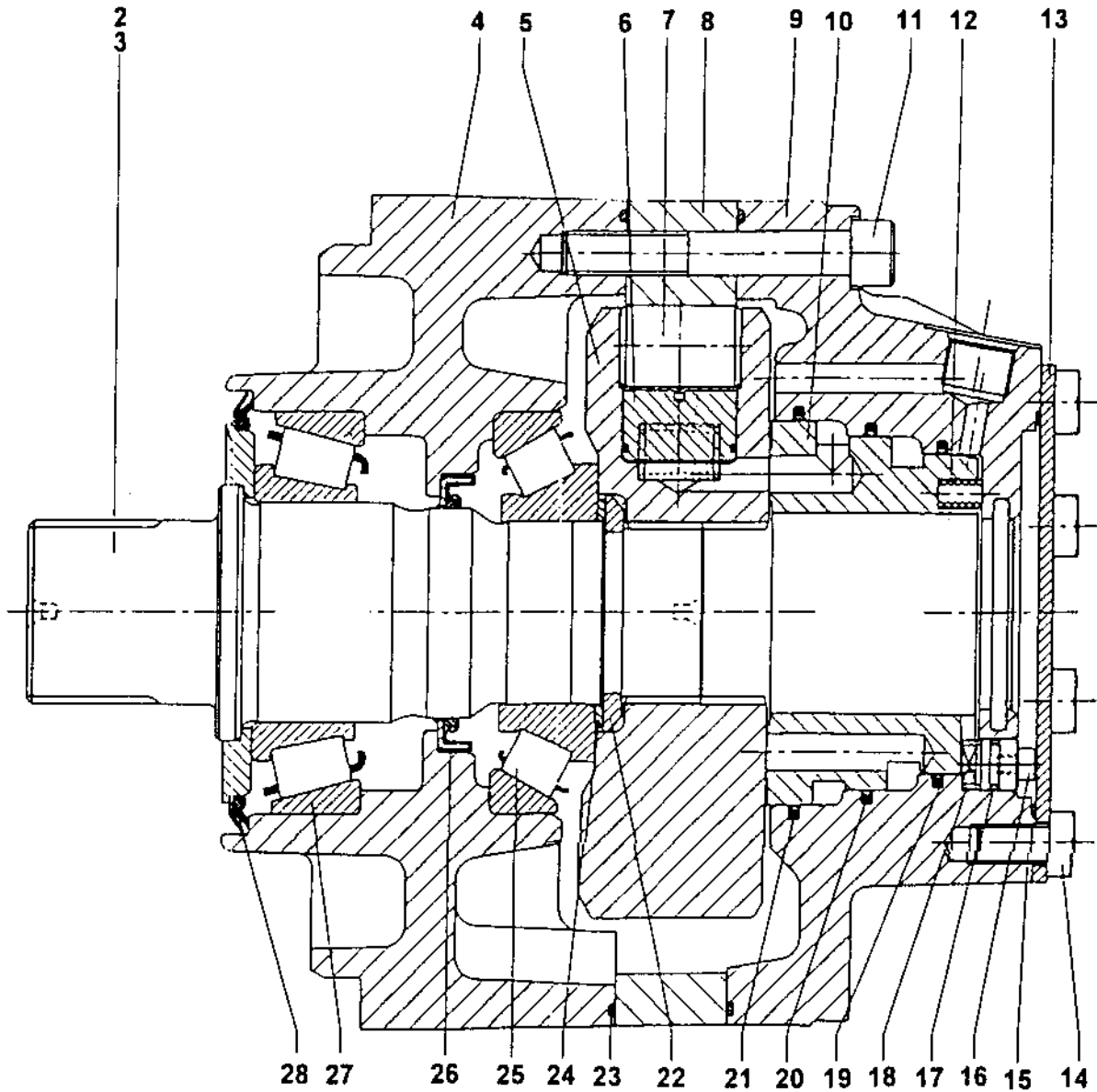

ITEM NO.	REED'S PARTS NO.	DESCRIPTION					QTY
		1	2	3	4	5	
-1	W-101240	Assembly, Agitator Drive Motor (See Group 20, Figure 07 for NHA)					Ref
2		• Assembly, Auger Drive Motor					1
3		• Shaft					1
4		• Case, Front					1
5		• Block, Cylinder					1
6		• Piston					8
7		• Roller					8
8		• Cam					1
9		• Case, Rear					1
10		• Ring, Distributor					1
11		• Screw, M12 Cap					12
12		• Spring					6
13	W-104755	• Plate, Cover					1
14		• Screw, M10 Hex					8
15		• O-Ring					1
16		• Screw, M5 Cap					1
17		• O-Ring					1
18		• Pin, Stop					1
19		• Seal, Rod					1
20		• Seal, Rod					1
21		• Seal, Rod					1
22	W-104395	• Ring, Split					1
23		• O-Ring					2
24		• Washer					1
25	W-105716	• Bearing					1
26		• Seal, Shaft					1
27	W-105715	• Bearing					1
28	W-101241	• Set, Sealing					1

DASH (-) ITEM NOT ILLUSTRATED

CONCRETE DECK PIPE LINE ASSEMBLY
(SEE GROUP 90, FIGURE 10 FOR REF)

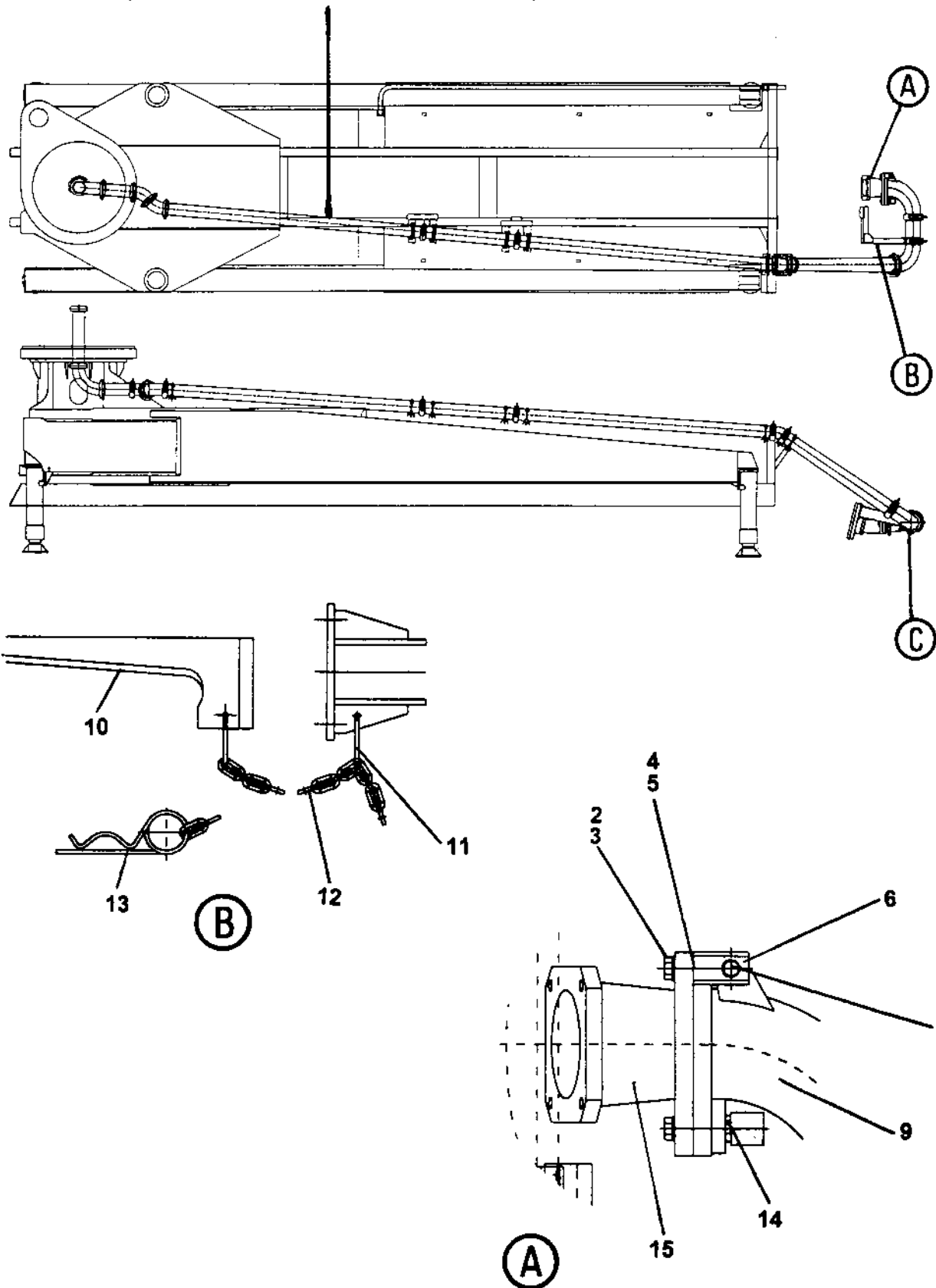



HOPPER OUTLET ASSEMBLY

XXT 42
PARTS
GROUP 20
FIGURE 09
PAGE 02

ITEM NO.	REED'S PARTS NO.	DESCRIPTION					QTY
		1	2	3	4	5	
-1	20-09	Assembly, Hopper Outlet (See Group 20, Figure 01 for NHA)					Ref
2	W-102848	• Screw, M24 Hex Head					3
3	W-102331	• Washer					3
4	B-194075	• Plate, Space					2
5	B-194076	• Plate, Space					2
6	B-194049	• Hinge					2
7	B-194050	• Bolt					1
8	W-100694	• Ring, Snap					2
9	W-104025	• O-Ring					1
10	B-194046	• Wedge, Locking					1
11	W-103731	• S-Hook					2
12	W-103732	• Chain, 1 Meter					1
13	W-101266	• Pin, Spring					3
14	B-194045	• Bolt, Locking					1
15	B-191010	• Reducer					1
16	801218	• Bracket, Hopper Elbow					1
17	801565	• Weldment, Cap					1
18	71530	• Coupling, Snap HD					1
19	800338	• Gasket, Coupling, Snap HD					1
20	W-100805	• Nipple, Grease					1
21	B-191015	• Elbow, Reducer					1
22	W-105165	• Coupling, Wedge					1
23	W105164	• O-Ring					1
24	B-193017	• Flange					1
25	801558	• Adapter, Hopper Elbow					1
26	B-194053	• Coupling, Snap					1
27	72242	• Coupling, Snap					2
28	800336	• Elbow, 90					1

DASH (-) ITEM NOT ILLUSTRATED

REVISION:

HOPPER OUTLET ASSEMBLY

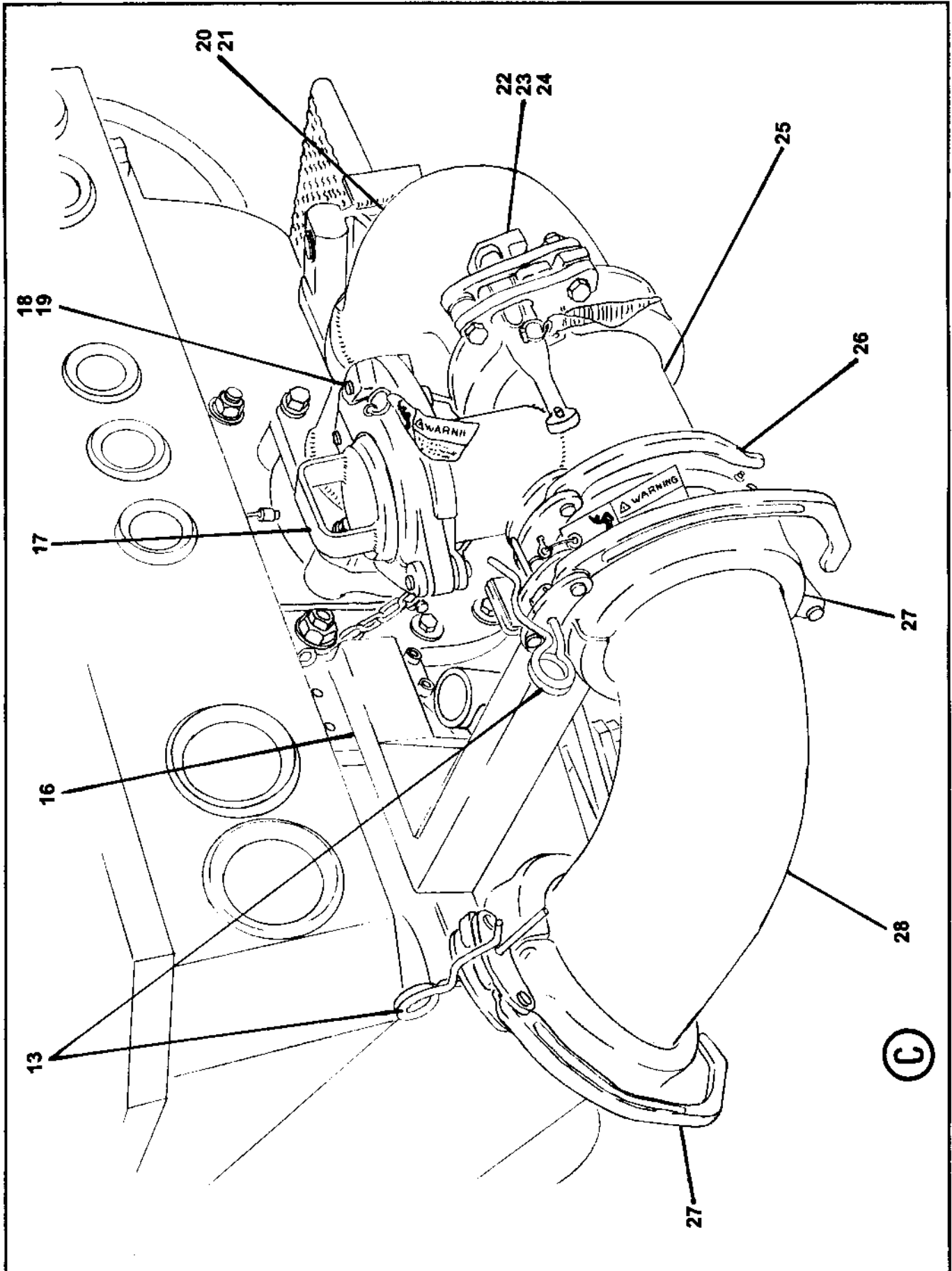



HOPPER OUTLET ASSEMBLY

XXT 42
PARTS
GROUP 20
FIGURE 09
PAGE 04

ITEM NO.	REED'S PARTS NO.	DESCRIPTION					QTY
		1	2	3	4	5	
-1	20-09	Assembly, Hopper Outlet (See Group 20, Figure 01 for NHA)					Ref
2	W-102848	• Screw, M24 Hex Head					3
3	W-102331	• Washer					3
4	B-194075	• Plate, Space					2
5	B-194076	• Plate, Space					2
6	B-194049	• Hinge					2
7	B-194050	• Bolt					1
8	W-100694	• Ring, Snap					2
9	W-104025	• O-Ring					1
10	B-194046	• Wedge, Locking					1
11	W-103731	• S-Hook					2
12	W-103732	• Chain, 1 Meter					1
13	W-101266	• Pin, Spring					3
14	B-194045	• Bolt, Locking					1
15	B-191010	• Reducer					1
16	801218	• Bracket, Hopper Elbow					1
17	801565	• Weldment, Cap					1
18	71530	• Coupling, Snap HD					1
19	800338	• Gasket, Coupling, Snap HD					1
20	W-100805	• Nipple, Grease					1
21	B-191015	• Elbow, Reducer					1
22	W-105165	• Coupling, Wedge					1
23	W105164	• O-Ring					1
24	B-193017	• Flange					1
25	801558	• Adapter, Hopper Elbow					1
26	B-194053	• Coupling, Snap					1
27	72242	• Coupling, Snap					2
28	800336	• Elbow, 90					1

DASH (-) ITEM NOT ILLUSTRATED

REVISION:

DRIVE CYLINDER LUBRICATION SYSTEM ASSEMBLY

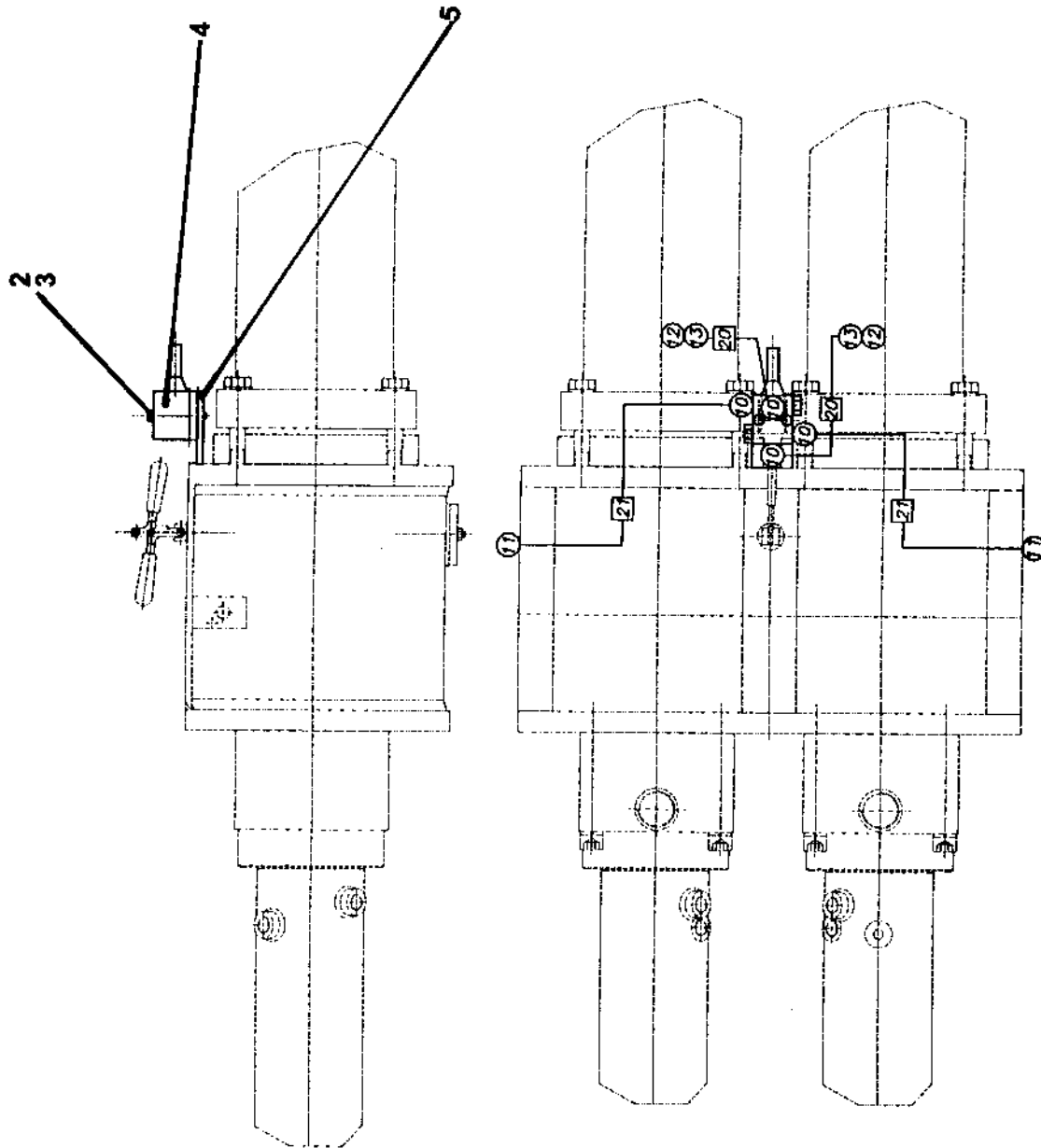



DRIVE CYLINDER LUBRICATION SYSTEM ASSEMBLY

XXT 42
PARTS
GROUP 20
FIGURE 10
PAGE 02

ITEM NO.	REED'S PARTS NO.	DESCRIPTION					QTY
		1	2	3	4	5	
-1	B-183006	Assembly, Drive Cylinder Lubrication System (See Group 20, Figure 01 for NHA)					Ref
2	W-105277	• Bolt, M8 Hex					2
3	W-102205	• Washer, Spring					2
4	W-104402	• Distributer (VSKH 2- D)					1
5	B-183008	• Bracket, Distributer					1
10	W-105202	• Coupling, STR Male Stud					4
11	W-101960	• Reducer, Pipe					2
12	W-102289	• Coupling, Straight Male Stud					2
13	W-100589	• Elbow, Adjustable					2
20	W-103515	• Hose, Hydraulic					2
21	W-105278	• Bar					2

DASH (-) ITEM NOT ILLUSTRATED



HOPPER LUBRICATION SYSTEM ASSEMBLY

XXT 42
PARTS
GROUP 20
FIGURE 11
PAGE 01

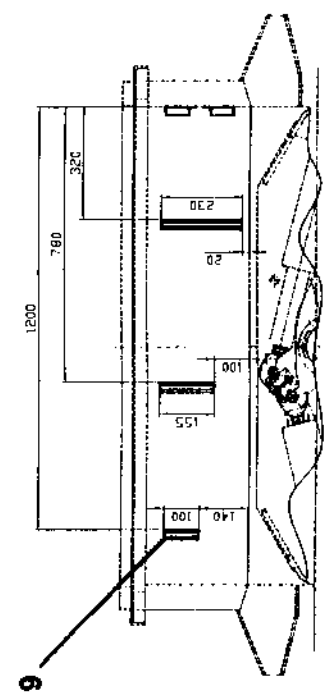
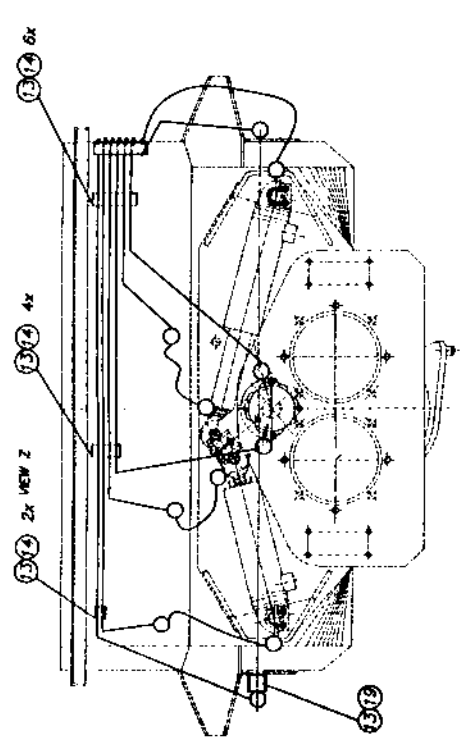
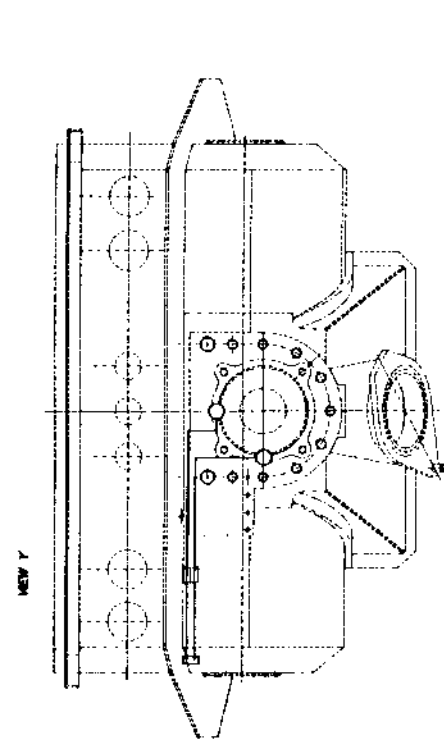
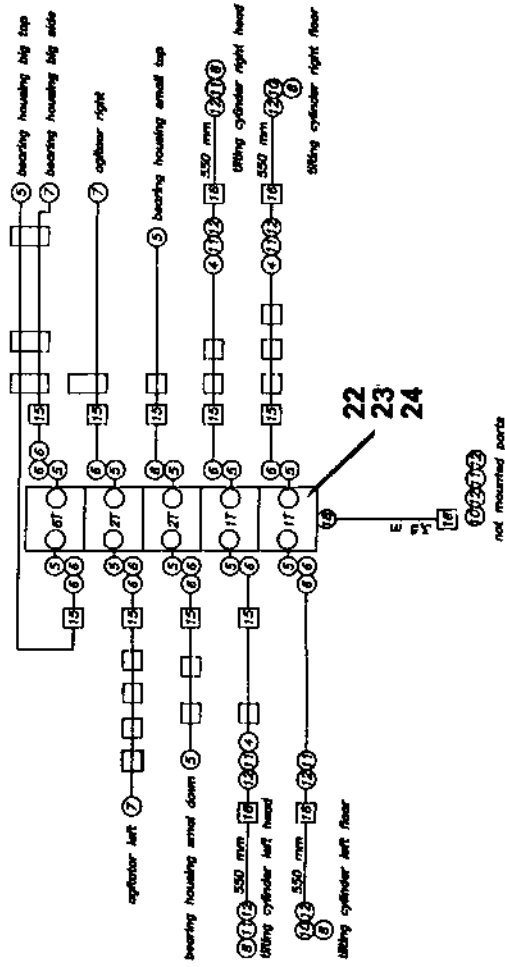
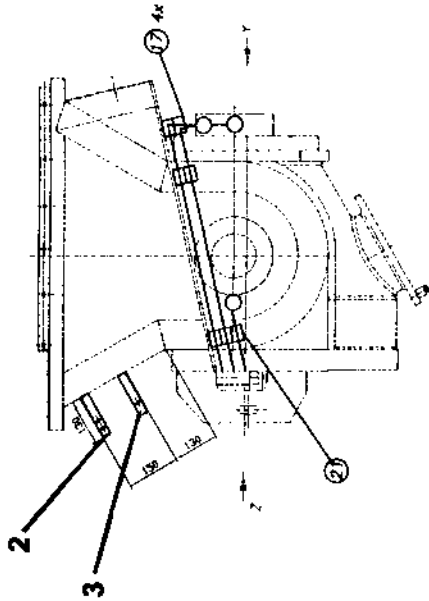

REVISION:

ITEM NO.	REED'S PARTS NO.	DESCRIPTION					QTY
		1	2	3	4	5	
-1	B-183007	Assembly, Hopper Lubrication System (See Group 20, Figure 01 for NHA)					Ref
2	B-184006	• Angle, Fixing					1
3	B-184007	• Angle, Fixing					1
4	W-105282	• Coupling, Straight					3
5	W-100546	• Coupling, Straight Male Stud					13
6	W-102664	• Elbow, Adjustable					15
7	W-102284	• Elbow, Throttle Free benjo					3
8	W-102603	• Stud, Male					4
9	W-102300	• Profile, Fixing					A/R
10	W-102643	• Sleeve, 90 Threaded					3
11	W-100253	• Piece, Hose Connection					7
12	W-100254	• Sleeve, Threaded					10
13	W-105144	• Clip, Pipe					13
14	W-105151	• Nut, Pipe Clamp Tee					24
15	W-105416	• Set, Pipe					1
16	W-100255	• Pipe, Plastic					6
17	W-105281	• Clip, Pipe					4
18	W-102665	• Coupling, Straight Male Stud					1
19	W-105422	• Plate, Welding					1
-20	W-103137	• Tie, Cable					10
21	W-104065	• Screw, M6 Hex					1
22	W-102602	• Assembly, Lubrication Distributor (See Group 20, Figure 12 for DET)					1
23	W-103512	• Screw, M6 Hex					3
24	W-102131	• Nut, Locking					3

DASH (-) ITEM NOT ILLUSTRATED



LUBRICATION DISTRIBUTOR ASSEMBLY

XXT 42
PARTS
GROUP 20
FIGURE 12
PAGE 01

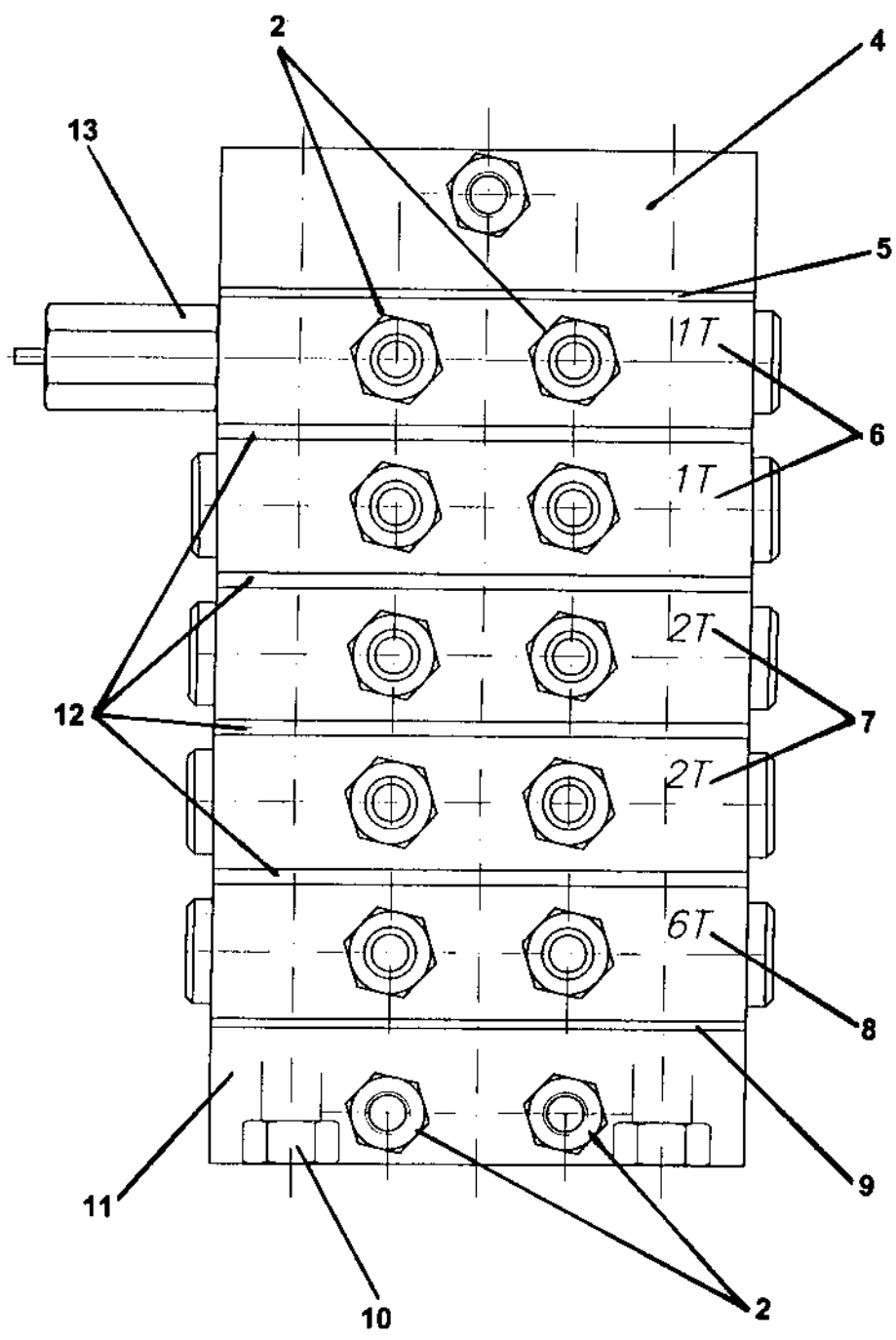

REVISION:



LUBRICATION DISTRIBUTOR ASSEMBLY

XXT 42

PARTS

GROUP 20

FIGURE 12

PAGE 02

ITEM NO.	REED'S PARTS NO.	DESCRIPTION					QTY
		1	2	3	4	5	
-1	W-102602	Assembly, Lubrication Distributor (See Group 20, Figure 11 for NHA)					Ref
2	W-100303	• Nipple, Grease					10
-3	W-102585	• Sub- Assembly, Lubrication Distributor					1
4	W-105757	•• Plate, End (VPM-4)					1
5	W-105763	•• Module, End (VP2-09)					1
6	W-105758	•• Plate, Distributor (VPM-K-1T)					2
7	W-105759	•• Plate, Distributor (VPM-K-2T)					2
8	W-105760	•• Plate, End (VPM-K-6T)					1
9	W-105761	•• Module, Input (VP2-07)					1
10	W-105765	•• Rod, Tension (VP-95)					2
11	W-105764	•• Plate, Input (VPM-E)					1
12	W-105762	•• Module, Distance (VP2-08)					4
13	W-102586	•• Indicator, Cycle) (VPM-ZY)					1

DASH (-) ITEM NOT ILLUSTRATED

REED

**MODEL XXT 42 TRUCK MOUNTED
CONCRETE BOOM PUMP
ILLUSTRATED PARTS MANUAL**

**XXT 42
PARTS
GROUP 20
FIGURE 13
PAGE 01**

THIS PAGE INTENTIONALLY LEFT BLANK.



REED TRUCK MOUNTED CONCRETE BOOM PUMP MODEL **XXT 42** ILLUSTRATED PARTS MANUAL GROUP 30 HYDRAULIC TANK INSTALLATION CONTAINS THE FOLLOWING FIGURES:

- FIGURE 00** TABLE OF CONTENTS
- FIGURE 01** TANK INSTALLATION
- FIGURE 02** WATER SYSTEM GROUP
- FIGURE 03** WATER PUMP MOTOR ASSEMBLY
- FIGURE 04** WASH WATER PUMP ASSEMBLY

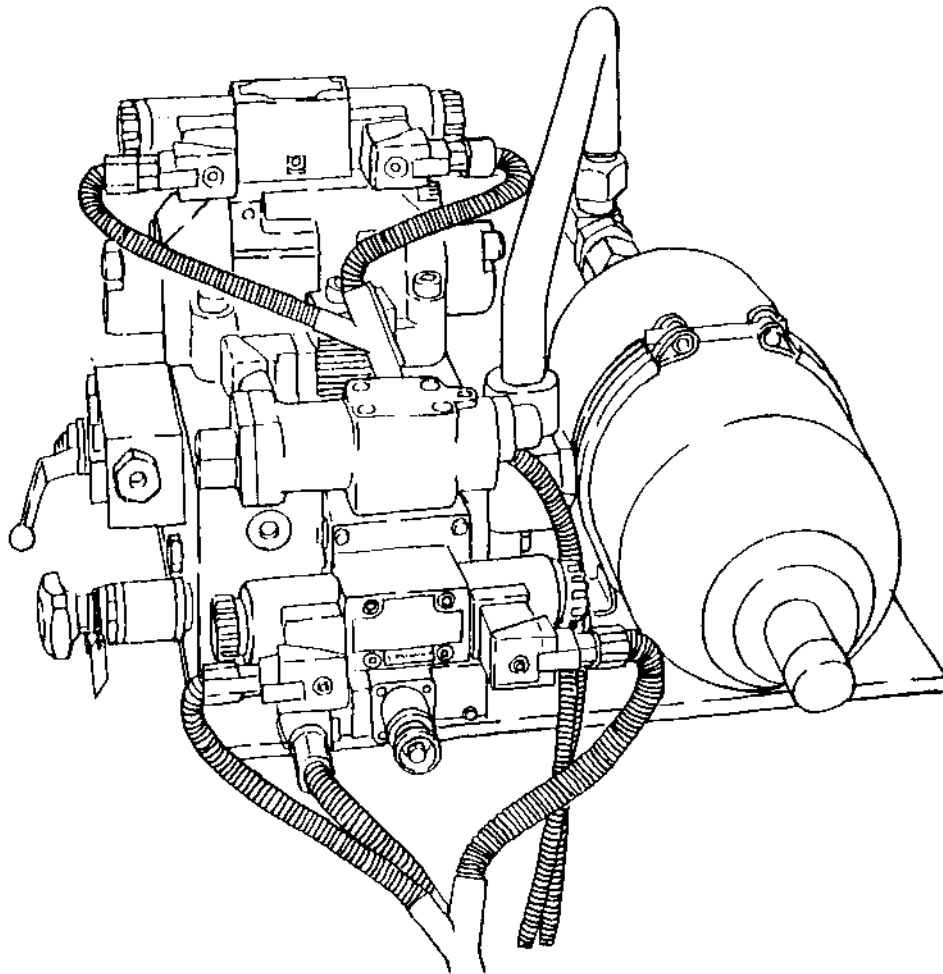

TANK INSTALLATION

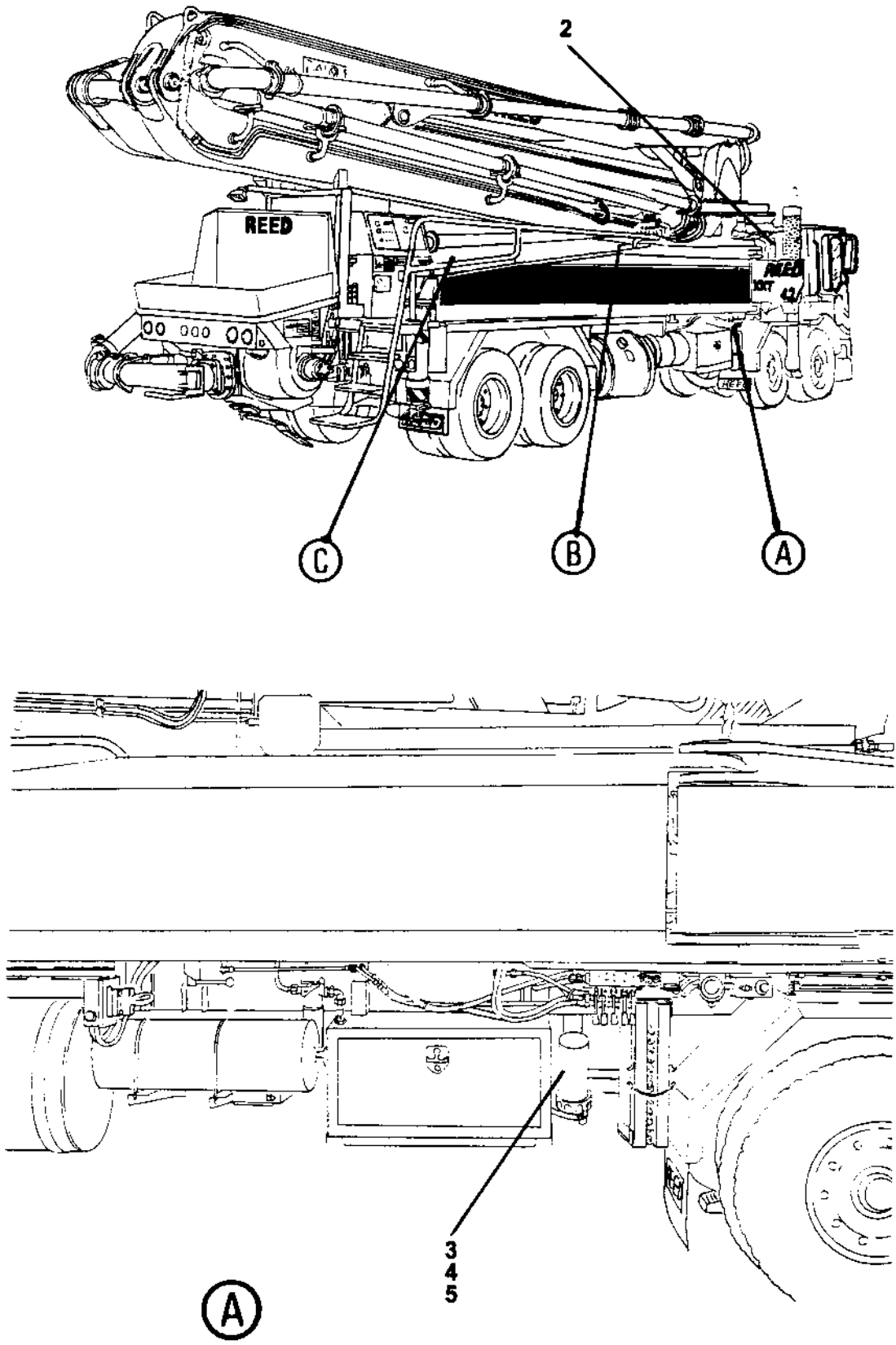

ITEM NO.	REED'S PARTS NO.	DESCRIPTION					QTY
		1	2	3	4	5	
-1	30-01	Installation, Tank (See Group 10, Figure 01 for NHA)					Ref
2	30-02	• Group, Water System (See Group 30, Figure 02 for DET)					1
3	W-105526	• Assembly, Boom High Pressure Filter					1
4	W-105527	• • Element, Boom High Pressure Filter					1
5	W-105556	• Indicator, Boom High Pressure Filter Visual Clogging					1
6	800654	• Assembly, Hydraulic Oil Cooler					1
7	801430	• • Modification, Hydraulic Oil Cooler					1
8	801629	• • Manifold, Hydraulic Oil Cooler					1
9	801496	• Assembly, Suction Filter					1
10	801498	• • Element, Suction Filter					2
11	W-105578	• Valve, Ball					1
12	W-104847	• Assembly, Swing Tube Manifold					1
13	W-105573	• Assembly, Swing Tube Circuit Solenoid Valve					1
-13A	W-105571	• • Kit, Seal					1
14	W-105581	• • Pilot, Solenoid Valve					1
15	W-105576	• • • Coil, Swing Tube Circuit Solenoid Valve					2
16	W-105572	• Cartridge, Solenoid Valve					1
17	W-105605	• • Coil					1
18	W-105579	• Valve, HP Limiter					1
-18A	W-105580	• • Kit, HP Limiter Valve Seal					1
19	W-103616	• Accumulator					1
20	71460	• Kit, Accumulator Charge (Optional Item) (See Group 80, Figure 02 for REF)					1
21	73171	• Bracket, Accumulator					A/R
22	W-105582	• Valve, Proportional Pilot					1
23	W-105606	• • Coil					1
24	W-105581	• Assembly, Pump Control Solenoid Valve					1
-24A	W-105575	• • Kit, Seal					1
25	W-105576	• • Coil, Pump Control Solenoid Valve					2
26	W-104846	• Assembly, Pump Control Manifold					1
27	W-105570	• Cartridge, Relief Valve					1
-27A	W-105571	• • Kit, Seal					1
28	W-105577	• Cartridge, Check Valve					1
29	W-104691	• Plug					4

DASH (-) ITEM NOT ILLUSTRATED

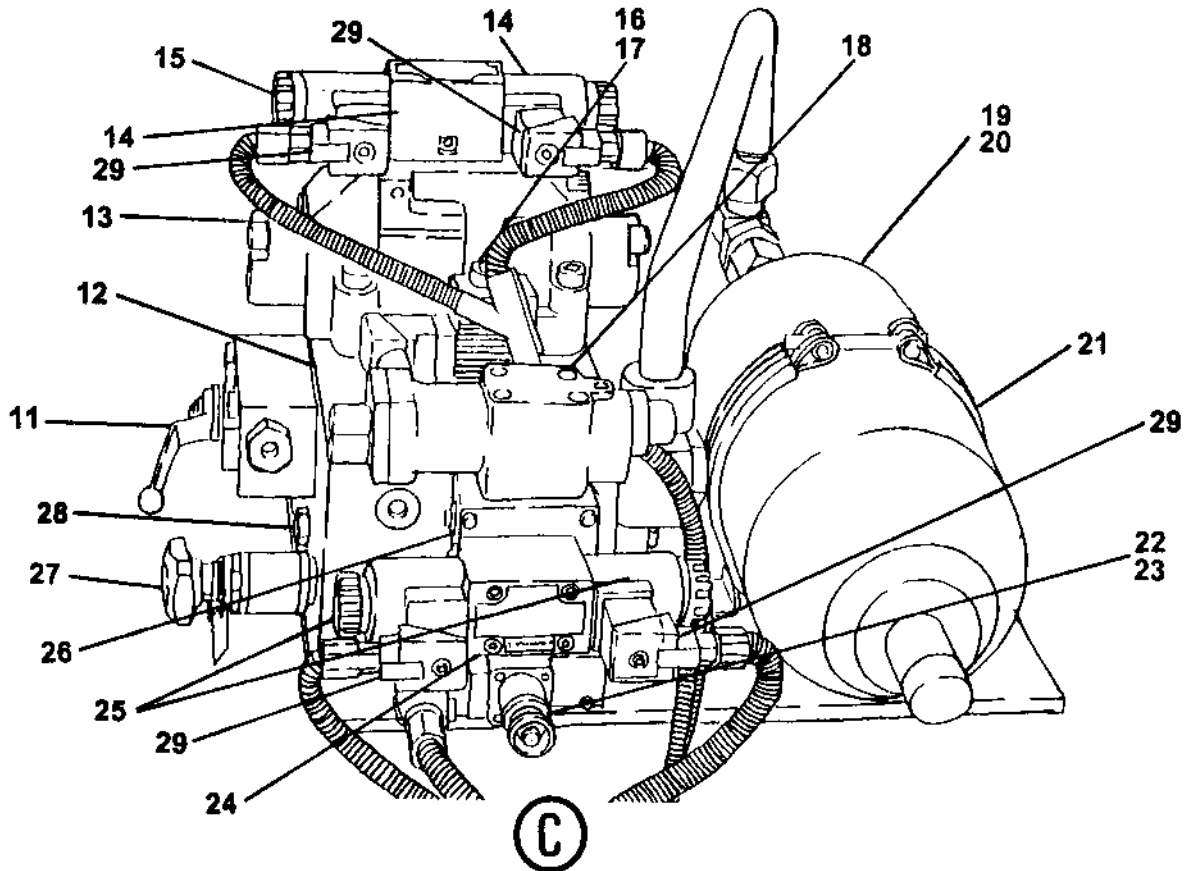
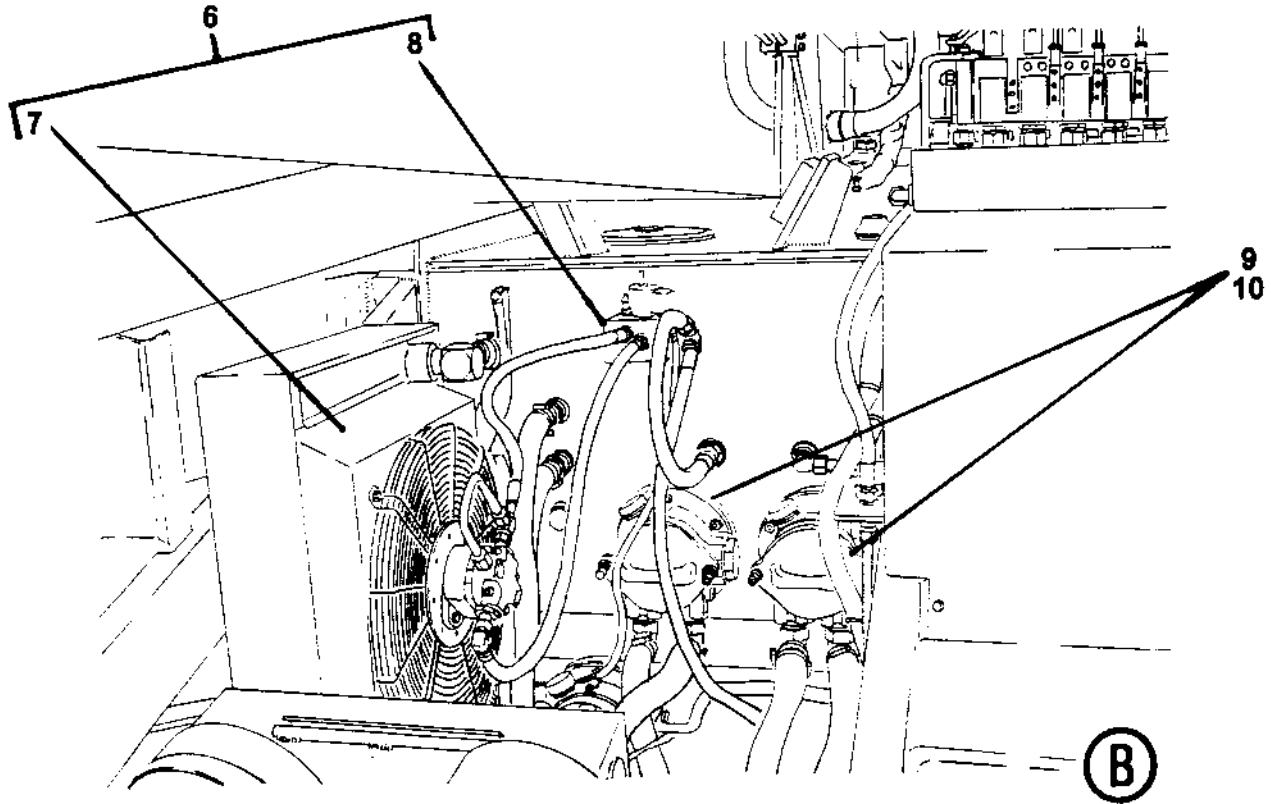

ITEM NO.	REED'S PARTS NO.	DESCRIPTION					QTY
		1	2	3	4	5	
-1	30-01	Installation, Tank (See Group 10, Figure 01 for NHA)					Ref
2	30-02	• Group, Water System (See Group 30, Figure 02 for DET)					1
3	W-105526	• Assembly, Boom High Pressure Filter					1
4	W-105527	• • Element, Boom High Pressure Filter					1
5	W-105556	• Indicator, Boom High Pressure Filter Visual Clogging					1
6	800654	• Assembly, Hydraulic Oil Cooler					1
7	801430	• • Modification, Hydraulic Oil Cooler					1
8	801629	• • Manifold, Hydraulic Oil Cooler					1
9	801496	• Assembly, Suction Filter					1
10	801498	• • Element, Suction Filter					2
11	W-105578	• Valve, Ball					1
12	W-104847	• Assembly, Swing Tube Manifold					1
13	W-105573	• Assembly, Swing Tube Circuit Solenoid Valve					1
-13A	W-105571	• • Kit, Seal					1
14	W-105581	• • Pilot, Solenoid Valve					1
15	W-105576	• • • Coil, Swing Tube Circuit Solenoid Valve					2
16	W-105572	• Cartridge, Solenoid Valve					1
17	W-105605	• • Coil					1
18	W-105579	• Valve, HP Limiter					1
-18A	W-105580	• • Kit, HP Limiter Valve Seal					1
19	W-103616	• Accumulator					1
20	71460	• Kit, Accumulator Charge (Optional Item) (See Group 80, Figure 02 for REF)					1
21	73171	• Bracket, Accumulator					A/R
22	W-105582	• Valve, Proportional Pilot					1
23	W-105606	• • Coil					1
24	W-105581	• Assembly, Pump Control Solenoid Valve					1
-24A	W-105575	• • Kit, Seal					1
25	W-105576	• • Coil, Pump Control Solenoid Valve					2
26	W-104846	• Assembly, Pump Control Manifold					1
27	W-105570	• Cartridge, Relief Valve					1
-27A	W-105571	• • Kit, Seal					1
28	W-105577	• Cartridge, Check Valve					1
29	W-104691	• Plug					4

DASH (-) ITEM NOT ILLUSTRATED

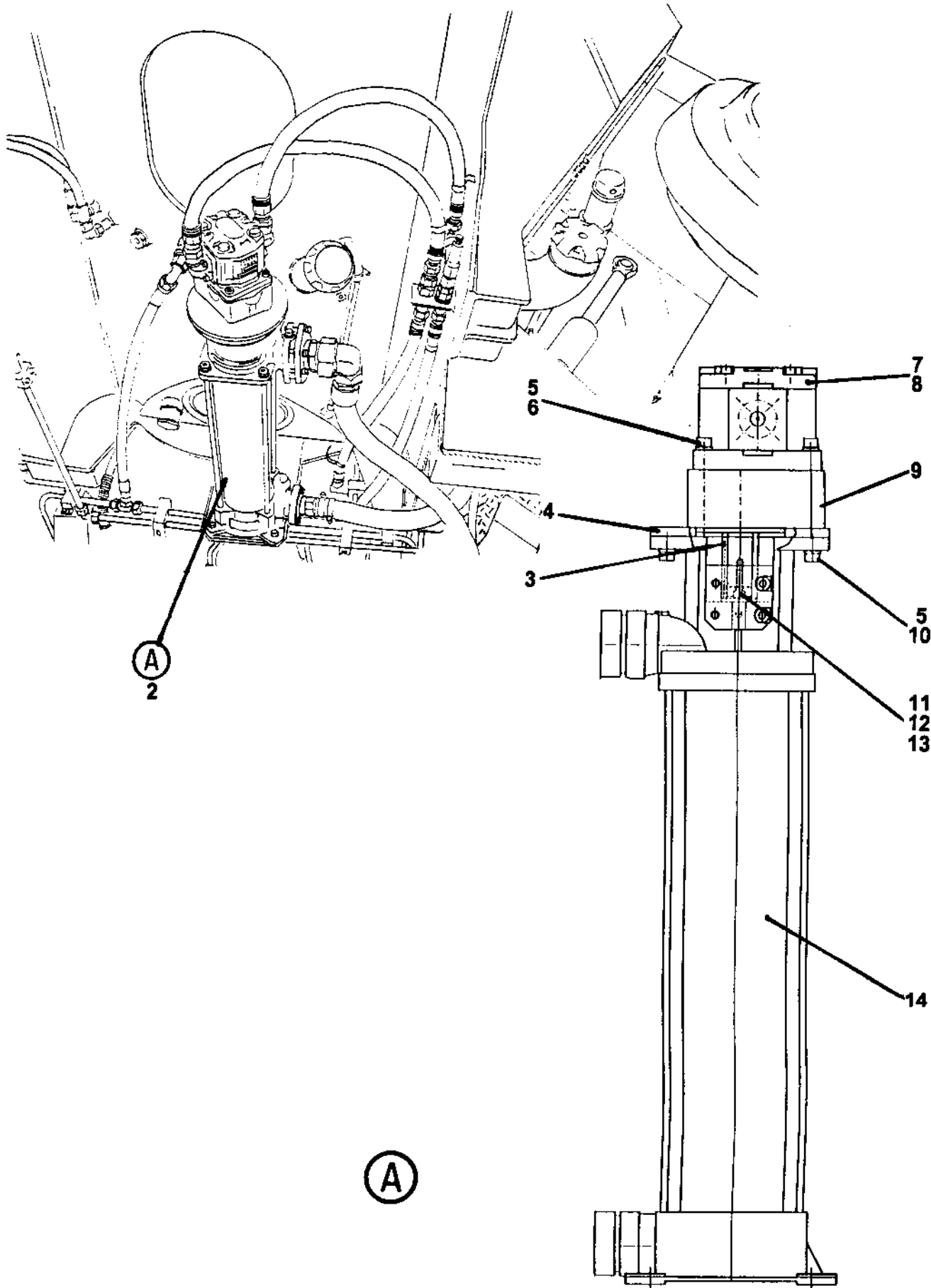

ITEM NO.	REED'S PARTS NO.	DESCRIPTION					QTY
		1	2	3	4	5	
-1	30-01	Group, Water System (See Group 30, Figure 01 for NHA)					Ref
2	B-323030	• Assembly, Water Pump And Drive					1
3	B-323019	• • Coupling					1
4	B-323016	• • Flange					1
5	W-105929	• • Screw, M8					4
6	W-100235	• • Washer, Spring					8
7	W-105922	• • Assembly, Water Pump Motor (See Group 30, Figure 03 for DET)					1
8	W-102916	• • Coupling, Splined					1
9	W-102915	• • Support, Belt Pulley					1
10	W-105930	• • Screw, M8					4
11	W-103673	• • Bolt, M6 Alien					1
12	W-105931	• • Ring, Locking					1
13	B-323021	• • Washer					1
14	W-101126	• • Assembly, Wash Water Pump (See Group 30, Figure 04 for DET)					1

DASH (-) ITEM NOT ILLUSTRATED

REED

WATER PUMP MOTOR ASSEMBLY

XXT 42
PARTS
GROUP 30
FIGURE 03
PAGE 01

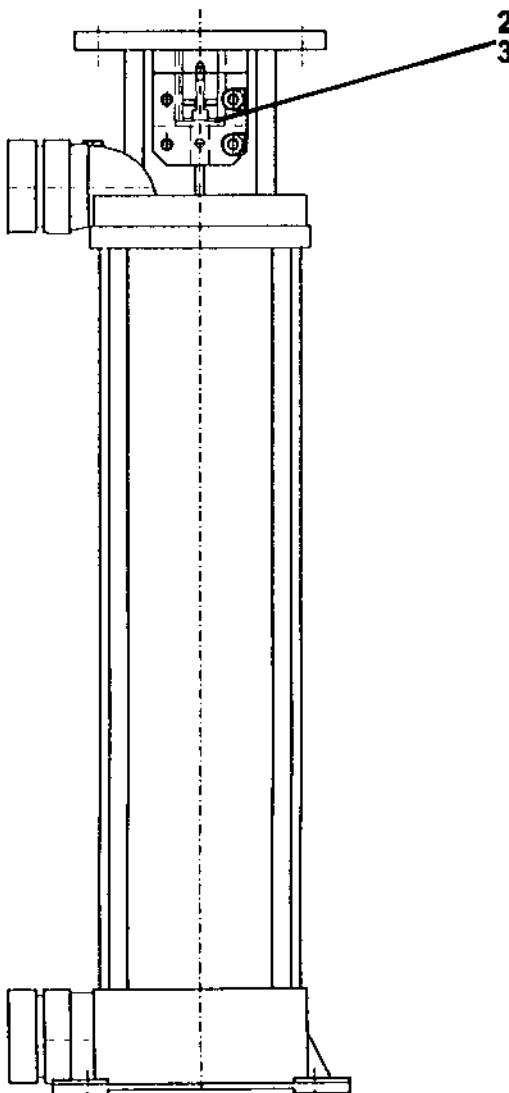

REED**WATER PUMP MOTOR ASSEMBLY****XXT 42****PARTS**

GROUP 30

FIGURE 03

PAGE 02

ITEM NO.	REED'S PARTS NO.	DESCRIPTION	QTY
-1	W-101126	1 2 3 4 5 Assembly, Water Pump Motor (See Group 30, Figure 02 for NHA)	Ref
2	W-105988	• Coupling	1
3	W-106043	• Kit, Seal	1

DASH (-) ITEM NOT ILLUSTRATED

REED

WASH WATER PUMP ASSEMBLY

XXT 42

PARTS

GROUP 30

FIGURE 04

PAGE 01

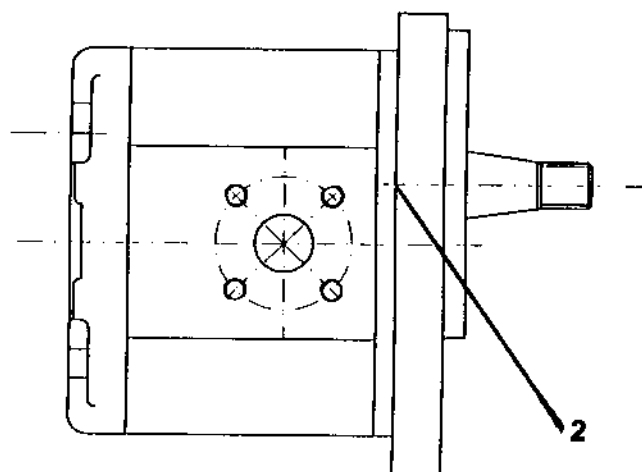

REED**WASH WATER PUMP ASSEMBLY****XXT 42**
PARTS
GROUP 30
FIGURE 04
PAGE 02

ITEM NO.	REED'S PARTS NO.	DESCRIPTION					QTY
		1	2	3	4	5	
-1	W-105922	Assembly, Wash Water Pump (See Group 30, Figure 02 for NHA)					Ref
2	W-106044	• Kit, Seal					1

DASH (-) ITEM NOT ILLUSTRATED

REED

**MODEL XXT 42 TRUCK MOUNTED
CONCRETE BOOM PUMP
ILLUSTRATED PARTS MANUAL**

**XXT 42
PARTS
GROUP 30
FIGURE 06
PAGE 01**

THIS PAGE INTENTIONALLY LEFT BLANK.





**MODEL XXT 42 TRUCK MOUNTED
CONCRETE BOOM PUMP
GROUP 40 POWER TRAIN INSTALLATION**

**XXT 42
PARTS
GROUP 40
FIGURE 00
PAGE 01**

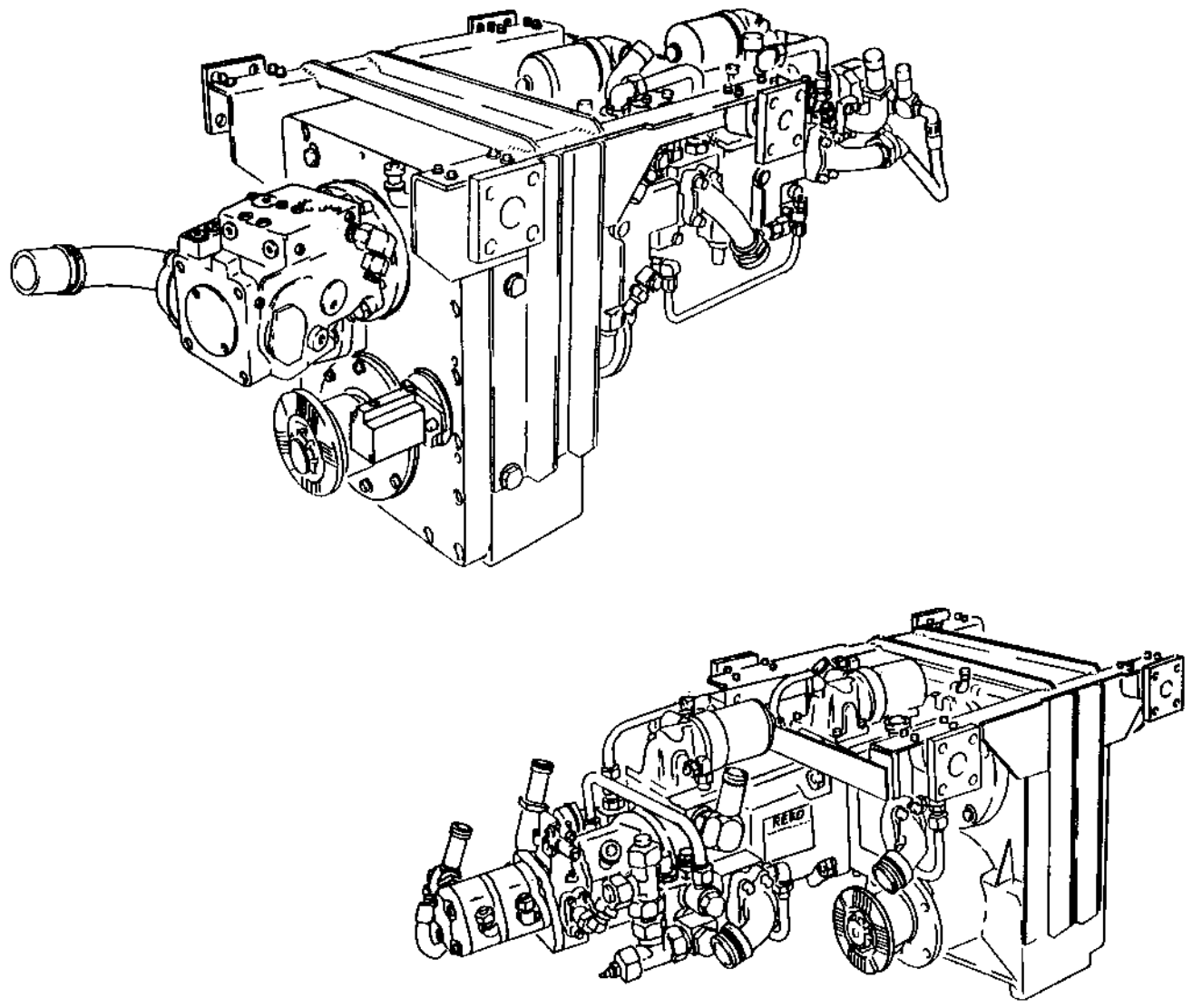

SHOWN MODEL: AFTER MARCH 2001

REED TRUCK MOUNTED CONCRETE BOOM PUMP MODEL XT 36 ILLUSTRATED PARTS MANUAL GROUP 40 POWER TRAIN INSTALLATION CONTAINS THE FOLLOWING FIGURES:

- FIGURE 00** TABLE OF CONTENTS
- FIGURE 01** POWER TRAIN INSTALLATION
- FIGURE 02** GEAR PUMP ASSEMBLY
- FIGURE 03** PTO GEARBOX ASSEMBLY

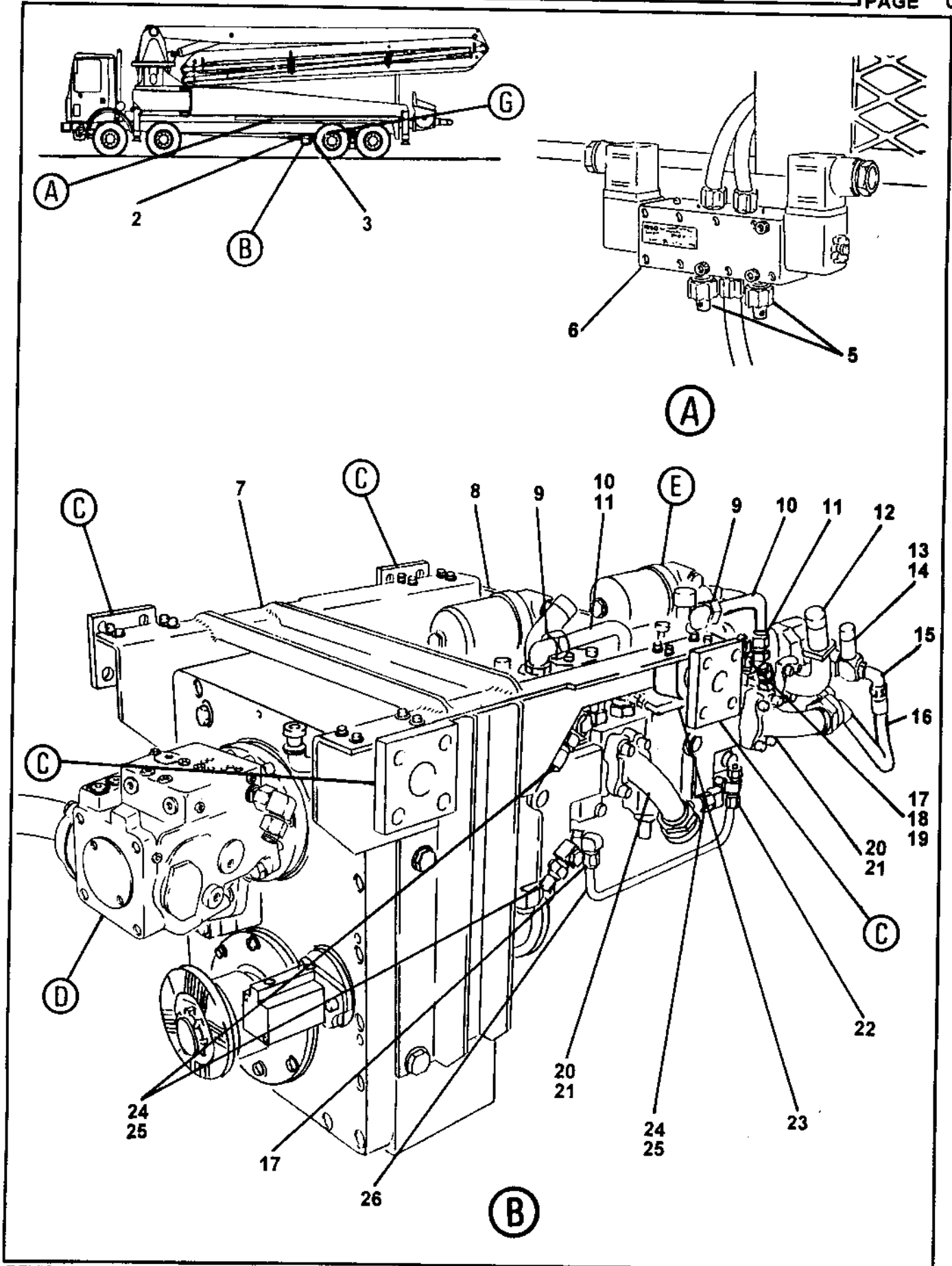

ITEM NO.	REED'S PARTS NO.	DESCRIPTION	QTY
-1	40-01	Installation, Power Train (See Group 10, Figure 01 for NHA)	Ref
2	801480	• Shaft, Front Drive	1
3	801481	• Shaft, Rear Drive	1
-4	800610	• Installation, XXT 42 PTO Gearbox	1
5	800064	• • Muffler, Air Valve	2
6	800063	• • Valve, Air	1
7	801788	• • Mount, PTO Gearbox with Rexroth	1
8	801792	• • Brace, PTO Mount	1
9	801888-005	• • Swivel, Elbow	7
10	801793	• • Assembly, Tube	2
11		• • Adapter, STR	2
12	801512	• • Adapter, 90L	1
13	801510	• • Adapter, 90L	1
14	801516	• • Adapter, STR	1
15	801888-014	• • Swivel, Elbow	3
16	801486-005	• • Assembly, Hose	1
17	801888-003	• • Swivel, Elbow	3
18	801890-003	• • Swivel, Tee	1
19	W-105076	• • Port, Pressure Test	3
20	801778	• • Manifold, Pump	2
21	801503	• • Adapter, 90L	4
22	801889-003	• • Swivel, Tee	1
23	802339	• • Assembly, Tube	1
24	801874-003	• • Banjo, Elbow	4
25	W-104831	• • Port, Pressure Test	4
26	801797	• • Assembly, Tube	1
27	W-104346	• • Assembly, Boom Pump	1
28A	W-105927	• • • Kit, Boom Pump Seal	1
28B	W-105928	• • • Seal, Boom Pump Shaft	1
29		• • Bolt, Hex	16
30		• • Washer	32
31		• • Nut, Lock	16
32	W-103414	• • Buffer, Rubber	4
33	800125	• • Axle, PTO Mount	4
34	800128	• • Plate, PTO Axle Mount	4
36	800061	• • • O-Ring, 4/4CC Pump	1
37	W-105650	• • Assembly, Gear Pump (See Group 40, Figure 02 for DET)	1

DASH (-) ITEM NOT ILLUSTRATED

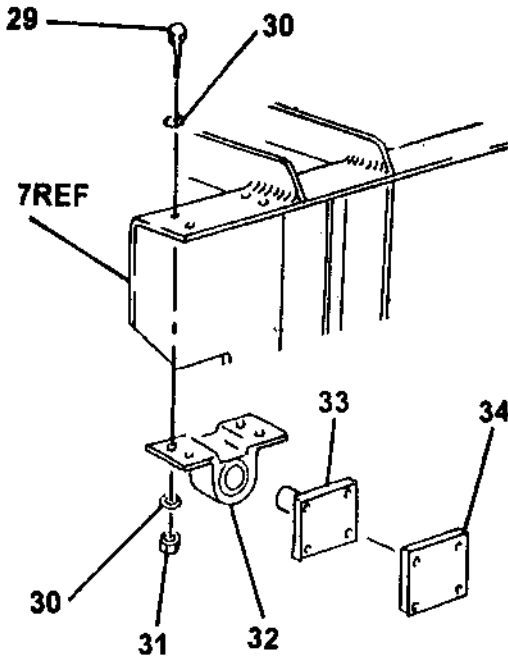

(C)

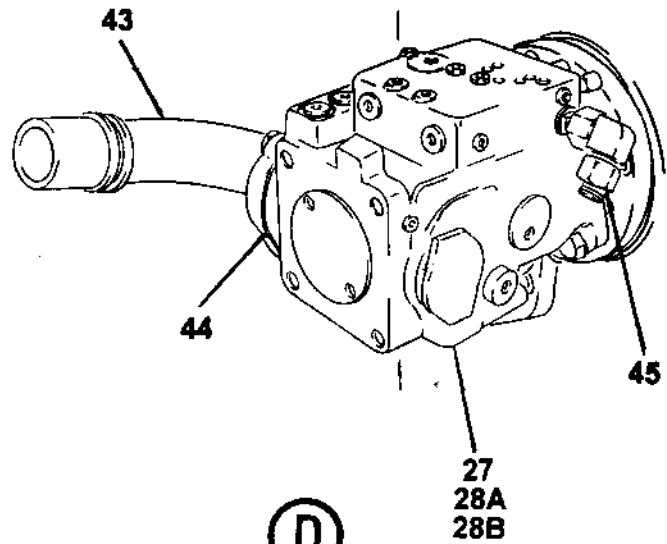

(D)

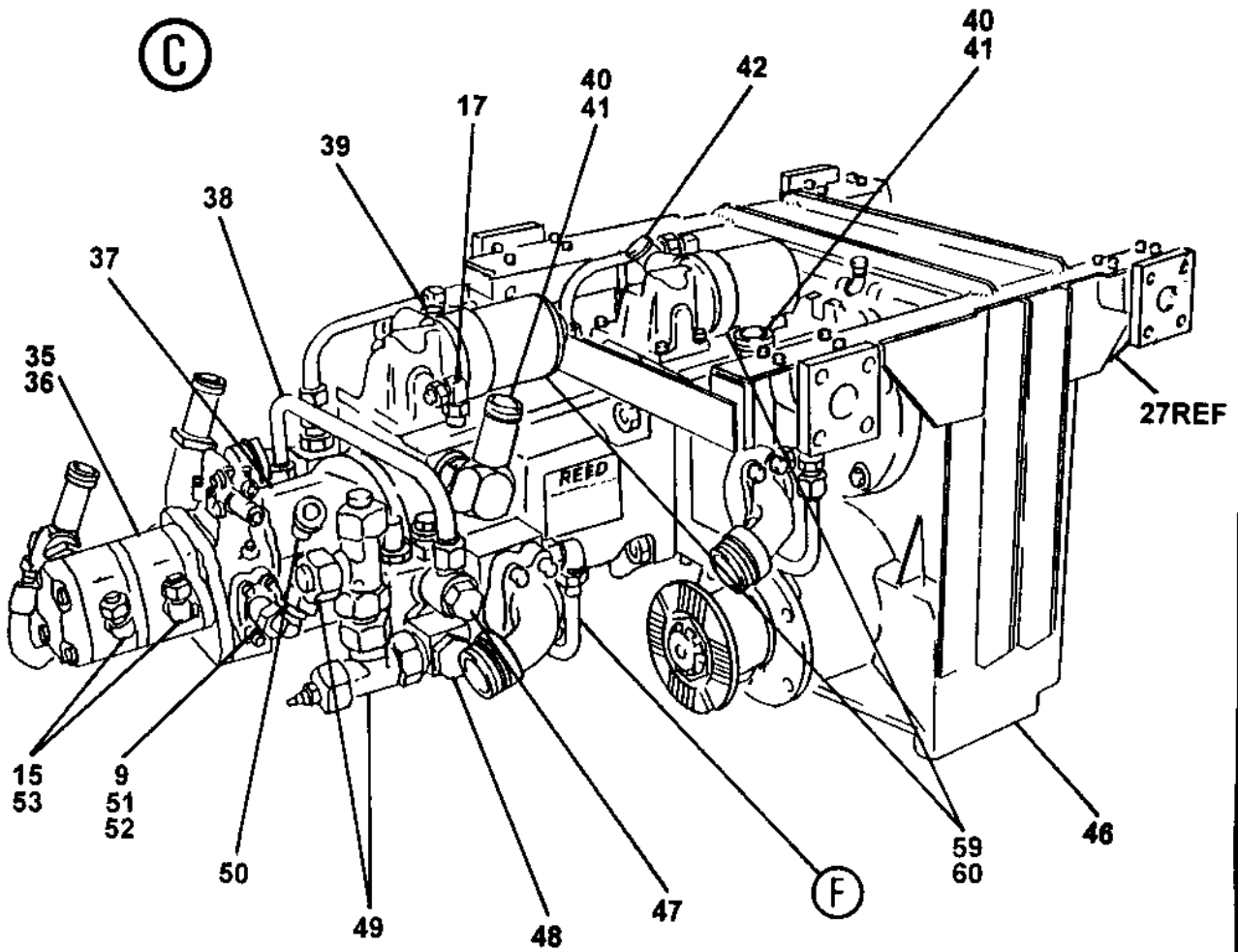

(E)

ITEM NO.	REED'S PARTS NO.	DESCRIPTION	QTY
24	801874-003	•• Banjo, Elbow	4
25	W-104831	•• Port, Pressure Test	4
26	801797	•• Assembly, Tube	1
27	W-104346	•• Assembly, Boom Pump	1
28A	W-105927	••• Kit, Boom Pump Seal	1
28B	W-105928	••• Seal, Boom Pump Shaft	1
29		•• Bolt, Hex	16
30		•• Washer	32
31		•• Nut, Lock	16
32	W-103414	•• Buffer, Rubber	4
33	800125	•• Axle, PTO Mount	4
34	800128	•• Plate, PTO Axle Mount	4
35	801684	•• Assembly, 4/4CC Pump	1
36	800061	••• O-Ring, 4/4CC Pump	1
37	W-105650	•• Assembly, Gear Pump (See Group 40, Figure 02 for DET)	1
38	801796	•• Assembly, Tube	1
39	W-105170	•• Adapter, STR	1
40	801506	•• Adapter, 90L	2
41	801526	•• Adapter, STR	2
42	W-105169	•• Adapter, 45	1
43	W-106581	•• Adapter, 90	1
44	86264-006	•• Flange, Split	1
45	801888-003	•• Swivel, Elbow	1
46	802242	•• Assembly, PTO Gear Box (See Group 40, Figure 03 for DET)	1
47	801527	•• Adapter, STR	1
48		•• Banjo	1
49	801890-006	•• Swivel, Tee	2
50	801876-005	•• Adapter, STR	1
51	86264-002	•• Flange, Split	1
52	W-105075	•• Adapter, STR	1
53	801876-003	•• Adapter	2
54	801057	•• Manifold, Pump	2
55	801794	•• Assembly, Tube	1
56	801795	•• Assembly, Tube	1
57	W-105567	•• Sensor, Thermal	1
58	801927	•• Adapter, Thermal Sensor	1
59	801499	•• Filter, A4VG125 Charge Pump	2
60	801500	••• Element, A4VG125 Charge Pump Filter	2

DASH (-) ITEM NOT ILLUSTRATED

REED

PTO GEAR BOX ASSEMBLY

XXT 42
PARTS
GROUP 40
FIGURE 01
PAGE 05

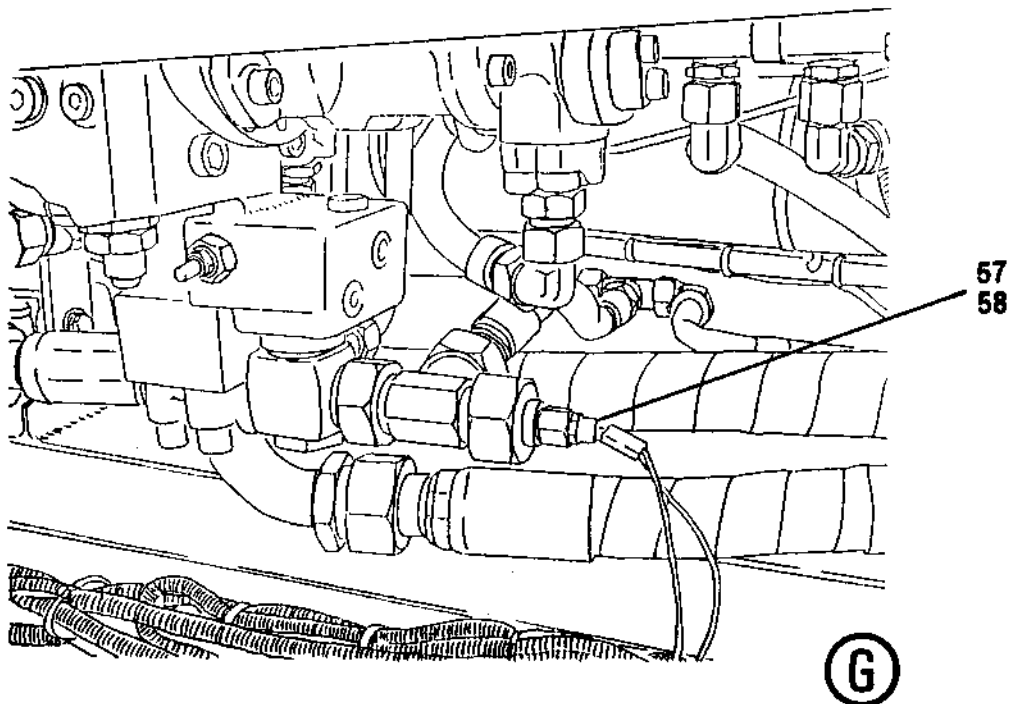
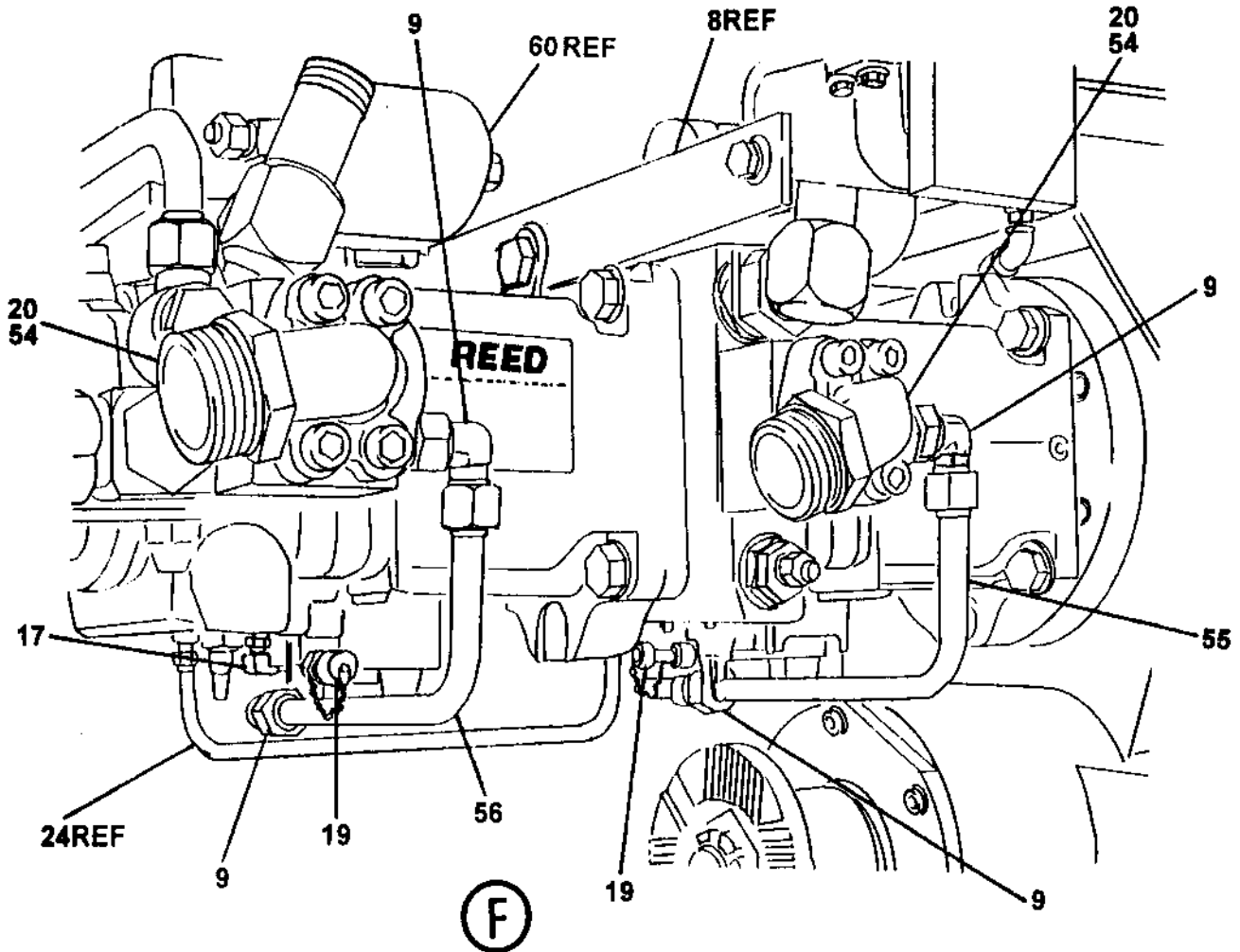

ITEM NO.	REED'S PARTS NO.	1 2 3 4 5	DESCRIPTION	QTY
24	801874-003	••	Banjo, Elbow	4
25	W-104831	••	Port, Pressure Test	4
26	801797	••	Assembly, Tube	1
27	W-104346	••	Assembly, Boom Pump	1
28A	W-105927	•••	Kit, Boom Pump Seal	1
28B	W-105928	•••	Seal, Boom Pump Shaft	1
29		••	Bolt, Hex	16
30		••	Washer	32
31		••	Nut, Lock	16
32	W-103414	••	Buffer, Rubber	4
33	800125	••	Axle, PTO Mount	4
34	800128	••	Plate, PTO Axle Mount	4
35	801684	••	Assembly, 4/4CC Pump	1
36	800061	•••	O-Ring, 4/4CC Pump	1
37	W-105650	••	Assembly, Gear Pump (See Group 40, Figure 02 for DET)	1
38	801796	••	Assembly, Tube	1
39	W-105170	••	Adapter, STR	1
40	801506	••	Adapter, 90L	2
41	801526	••	Adapter, STR	2
42	W-105169	••	Adapter, 45	1
43	W-106581	••	Adapter, 90	1
44	86264-006	••	Flange, Split	1
45	801888-003	••	Swivel, Elbow	1
46	802242	••	Assembly, PTO Gear Box (See Group 40, Figure 03 for DET)	1
47	801527	••	Adapter, STR	1
48		••	Banjo	1
49	801890-006	••	Swivel, Tee	2
50	801876-005	••	Adapter, STR	1
51	86264-002	••	Flange, Split	1
52	W-105075	••	Adapter, STR	1
53	801876-003	••	Adapter	2
54	801057	••	Manifold, Pump	2
55	801794	••	Assembly, Tube	1
56	801795	••	Assembly, Tube	1
57	W-105567	••	Sensor, Thermal	1
58	801927	••	Adapter, Thermal Sensor	1
59	801499	••	Filter, A4VG125 Charge Pump	2
60	801500	•••	Element, A4VG125 Charge Pump Filter	2

DASH (-) ITEM NOT ILLUSTRATED

GEAR PUMP ASSEMBLY

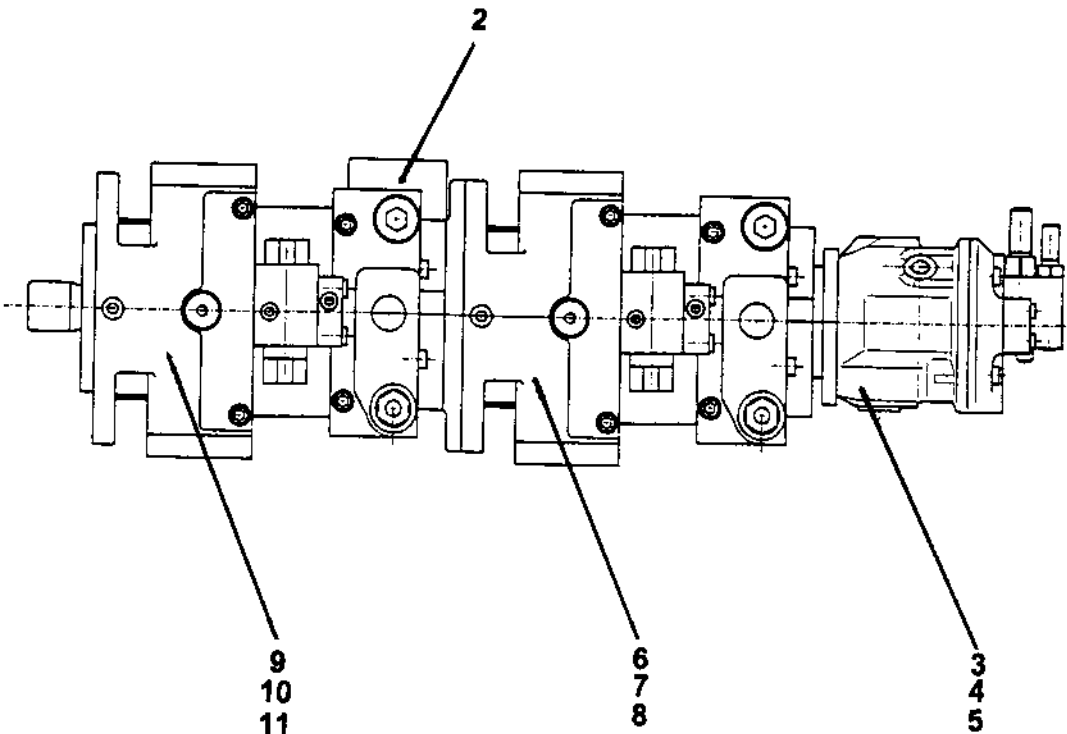

ITEM NO.	REED'S PARTS NO.	DESCRIPTION					QTY
		1	2	3	4	5	
-1	W-105650	Assembly, Gear Pump (See Group 40, Figure 01 for NHA)					1
2	W-104949	• Valve, Flushing					1
3	W-105651	• Assembly, A10VO28 Gear Pump					1
4	W-105789	• • Kit, A10VO28 Gear Pump Seal					1
5	W-105001	• Seal, Shaft					1
6	W-105592	• Assembly, A4VG125 Gear Pump					1
7	W-105787	• • Kit, A4VG125 Gear Pump Seal					1
8	W-105788	• Seal, Shaft					1
9	W-105591	• Assembly, A4VG125 Gear Pump					1
10	W-105785	• • Kit, A4VG125 Gear Pump Seal					1
11	W-105786	• Seal, Shaft					1

DASH (-) ITEM NOT ILLUSTRATED

ITEM NO.	REED'S PARTS NO.	DESCRIPTION					QTY
		1	2	3	4	5	
-1	802243	Assembly, XXT 42 PTO Gear Box (See Group 40, Figure 01 for NHA)					Ref
10	802160	• Cylinder, PTO Shift					1
20	802161	• Adapter, Shaft					1
30	802163	• Cap, Packing Ring					2
35	802164	• Flange, Mounting					1
40	802165	• Flange, Mounting					1
50	802166	• Cover					1
55	802332	• Cover					1
60	802168	• Gear, Coupling					1
70	802169	• Gear					1
80	802170	• Gear					1
90	802171	• Gear					1
100	802172	• Shaft, Toothed					1
110	802333	• Shaft, Coupling					1
120	802174	• Shaft, Toothed					1
130	802175	• Shaft, Splined Hollow					1
140	802176	• Flange, Mounting					1
150	802177	• Coupling					1
160	802178	• Spacer					1
170	802179	• Adapter, Shaft					1
175	802180	• Ring, Running					2
180	802181	• Flange					2
190	802182	• Housing, Gearbox					1
200	802183	• Fork, Gear					10
210	802184	• Bearing, Ball					1
220	802185	• Bearing, Ball					1
230	802186	• Bearing, Ball					1
240	802187	• Bearing, Ball					2
245	802188	• Bearing, Ball					1
250	802189	• Bearing					1
260	802190	• Bearing, Roller					1
270	802191	• Bearing, Roller					1
280	802192	• Seal, Radial Oil					1
290	802193	• Seal, Radial Oil					1
300	802194	• Seal, Radial Oil					2
310	802195	• O-Ring					1
315	802196	• O-Ring					1
320	802197	• O-Ring					1
330	802198	• O-Ring					1
335	802199	• O-Ring					2
340	802200	• O-Ring					1

DASH (-) ITEM NOT ILLUSTRATED

PTO GEARBOX ASSEMBLY

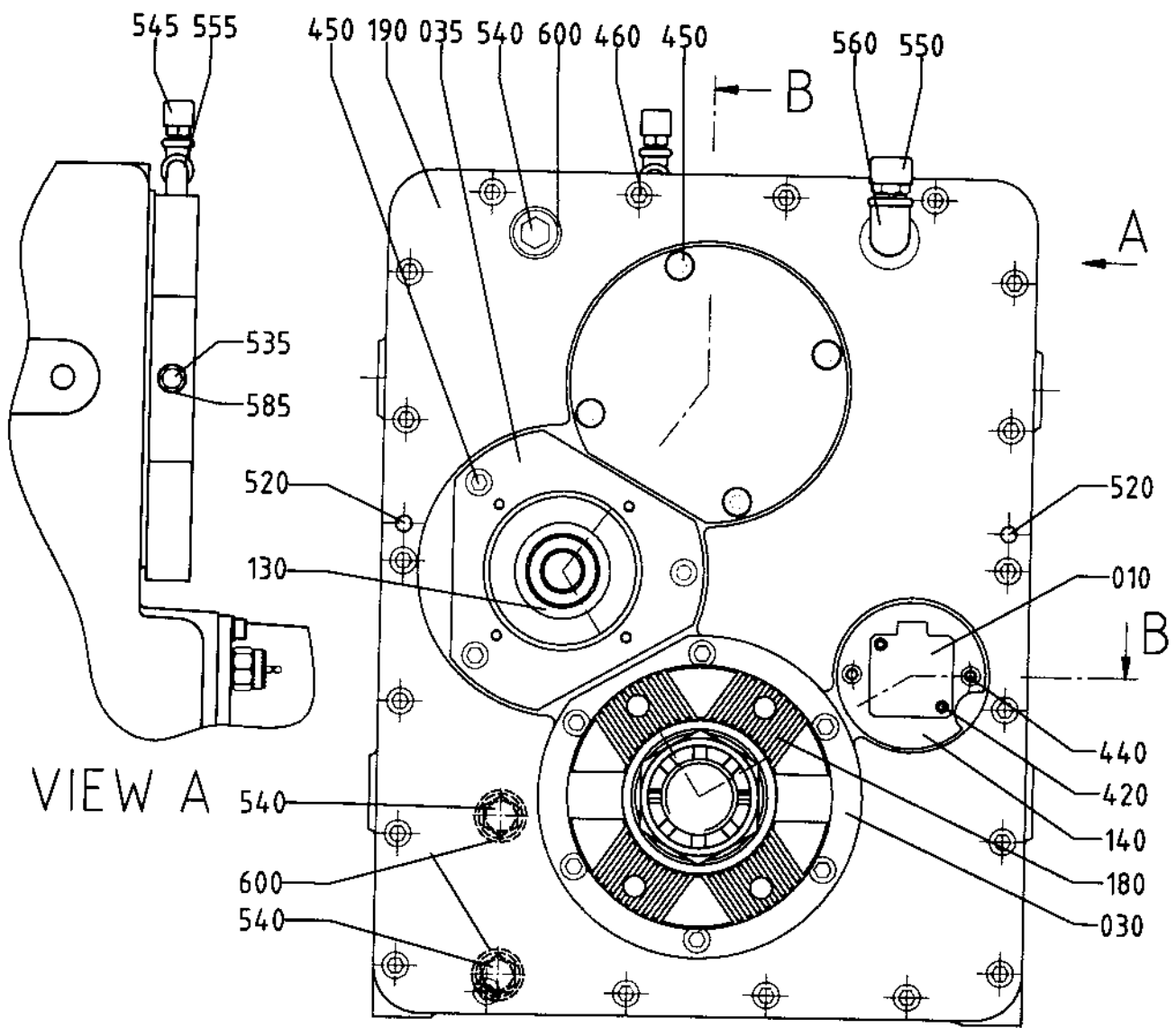

VIEW A



PTO GEARBOX ASSEMBLY

XXT42
PARTS
GROUP 40
FIGURE 03
PAGE 03

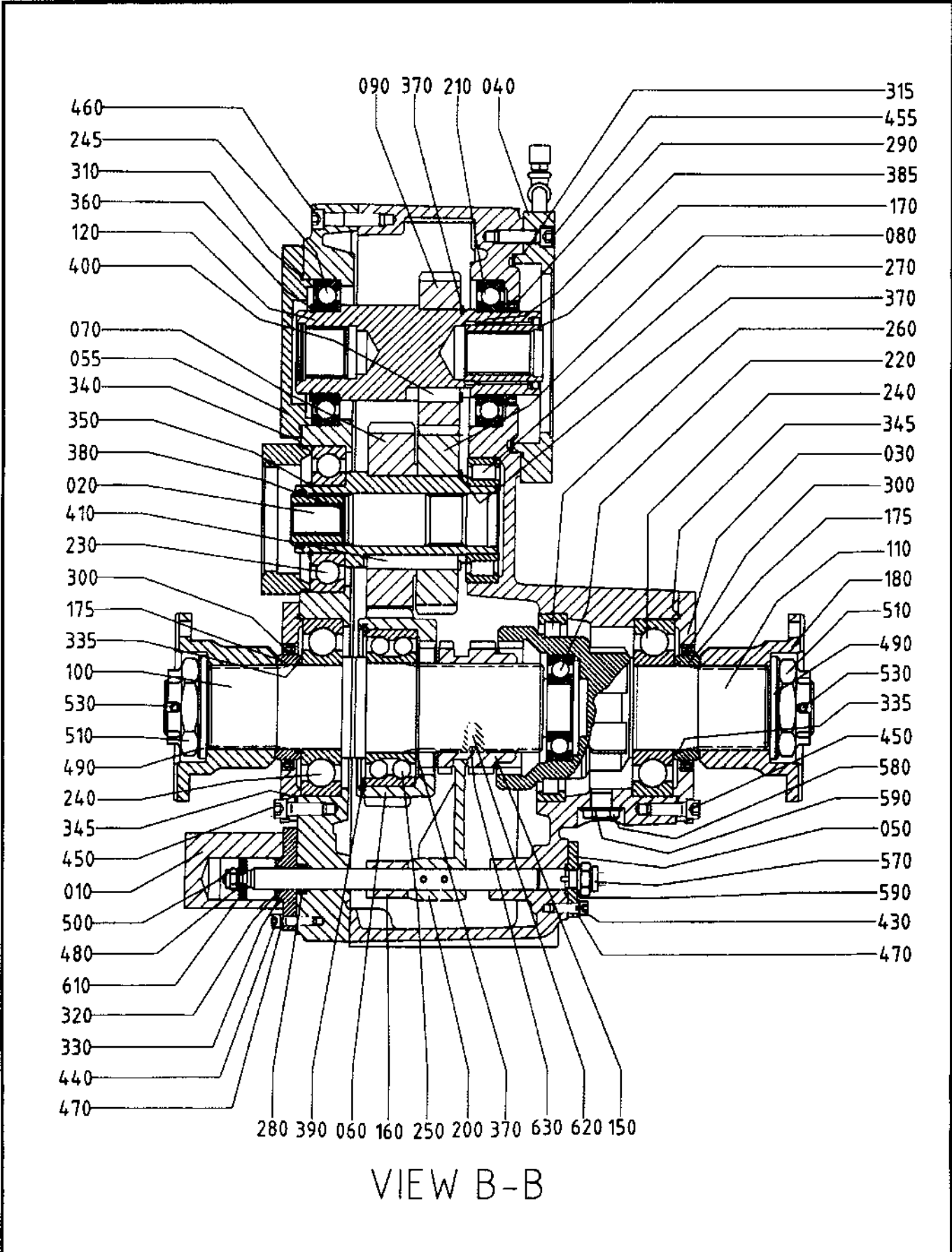

REED**PTO GEAR BOX ASSEMBLY****XXT 42
PARTS
GROUP 40
FIGURE 03
PAGE 04**

ITEM NO.	REED'S PARTS NO.	DESCRIPTION					QTY
		1	2	3	4	5	
340	802200	• O-Ring					1
345	802201	• O-Ring					2
350	802202	• Ring, Retaining					1
360	802203	• Ring, Retaining					1
370	802204	• Ring, Retaining					3
380	802205	• Ring, Retaining					2
385	802206	• Ring, Retaining					1
390	802207	• Ring, Retaining					1
392	802208	• Ring, Retaining					1
395	802209	• Disk, Support					1
398	802210	• Disk, Support					1
400	802211	• Key					2
410	802212	• Key					2
420	802213	• Screw, Socket Head Cap					2
430	802214	• Screw, Socket Head Cap					2
440	802215	• Screw, Socket Head Cap					2
450	802216	• Screw, Socket Head Cap					19
455	802217	• Screw, Socket Head Cap					8
460	802218	• Screw, Socket Head Cap					18
470	802219	• Washer, Lock					4
480	802220	• Disk					1
490	802221	• Disk					2
500	802222	• Nut, Hex					1
510	802223	• Nut, Castle					2
520	802224	• Pin					2
530	802225	• Pin, Spring					2
535	802226	• Plug, Hex Head					1
540	802227	• Plug, Hex Head					3
545	802228	• Filter, Vent					1
550	802229	• Filter, Vent					1
555	802230	• Elbow					2
560	802231	• Elbow					1
570	802232	• Switch, Limit					1
580	802233	• Plug, Hex Head					1
-585	802234	• Ring, Sealing					1
590	802235	• Ring, Sealing					2
600	802236	• Ring, Sealing					3
-605	802237	• Plug, Screw					2
610	802238	• Assembly, Piston					1
-615	802239	• Plug, Screw					1
620	802240	• Spring					1
630	802241	• Ball, 1/4 IN					1

DASH (-) ITEM NOT ILLUSTRATED

REED

**MODEL XXT 42 TRUCK MOUNTED
CONCRETE BOOM PUMP
ILLUSTRATED PARTS MANUAL**

**XXT 42
PARTS
GROUP 40
FIGURE 04
PAGE 01**

THIS PAGE INTENTIONALLY LEFT BLANK.



REED TRUCK MOUNTED CONCRETE BOOM PUMP MODEL **XXT 42** ILLUSTRATED PARTS MANUAL GROUP 50 CONTROLS INSTALLATION CONTAINS THE FOLLOWING FIGURES:

- FIGURE 00 TABLE OF CONTENTS
- FIGURE 01 CONTROLS INSTALLATION
- FIGURE 02 CAB CONTROLS ASSEMBLY
- FIGURE 03 MAIN CONTROLS ASSEMBLY
- FIGURE 04 DRIVER (L. H.) SIDE OUTRIGGER CONTROLS ASSEMBLY
- FIGURE 05 PASSENGER (R. H.) SIDE OUTRIGGER CONTROLS ASSEMBLY
- FIGURE 06 STATIONARY BOOM CONTROLS ASSEMBLY
- FIGURE 07 CABLED REMOTE CONTROL ASSEMBLY
- FIGURE 08 RADIO REMOTE CONTROL ASSEMBLY
- FIGURE 09 SHUNT ASSEMBLY

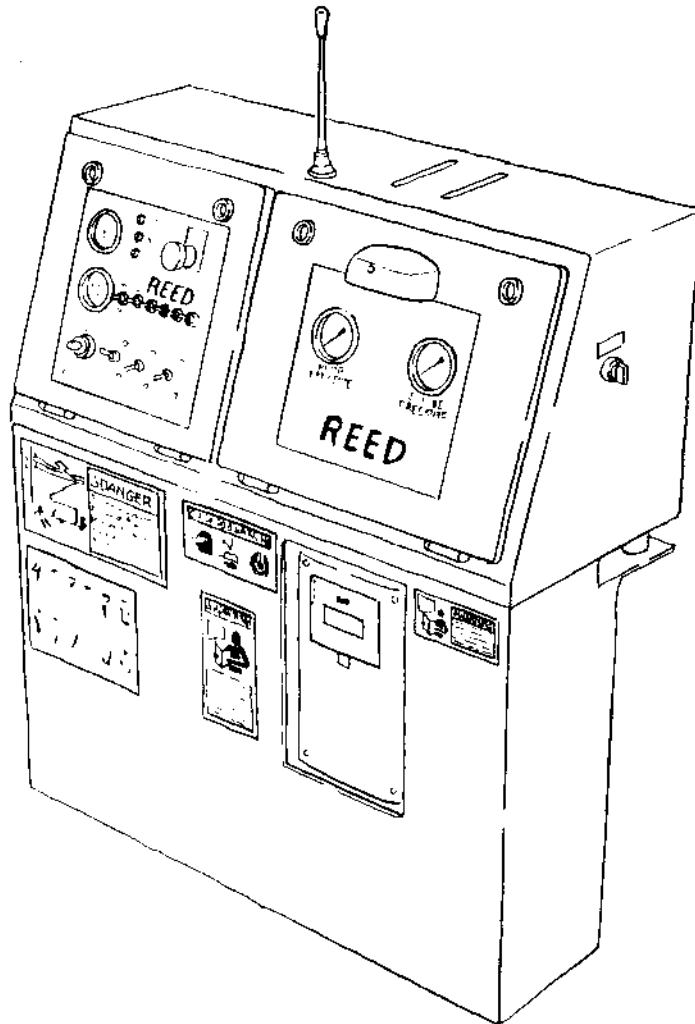



CONTROLS INSTALLATION

XXT 42
PARTS
GROUP 50
FIGURE 01
PAGE 01

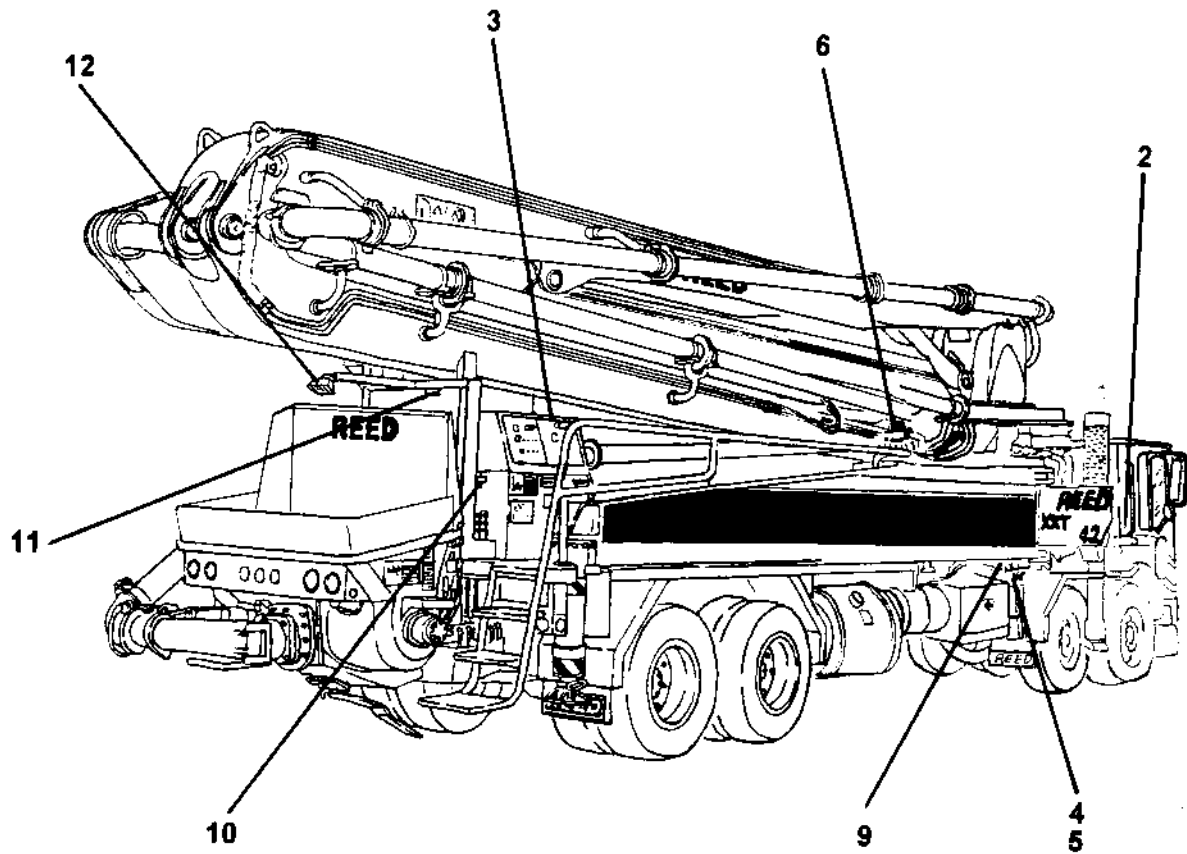

ITEM NO.	REED'S PARTS NO.	DESCRIPTION					QTY
		1	2	3	4	5	
-1	50-01	Installation, XXT 42 Controls (See Group 10, Figure 01 for NHA)					Ref
2	800710	• Assembly, Cab Controls (See Group 50, Figure 02 for DET)					1
3	50-03	• Assembly, Main Controls (See Group 50, Figure 03 for DET)					1
4	50-04	• Assembly, Driver (L. H.) Side Outrigger Controls (See Group 50, Figure 04 for DET)					1
5	50-05	• Assembly, Passenger (R. H.) Side Outrigger Controls (See Group 50, Figure 05 for DET)					1
6	C-DD103	• Assembly, Stationary Boom Controls (See Group 50, Figure 06 for DET)					1
-7	W-105565	• Assembly, Cabled Remote Control (See Group 50, Figure 07 for DET)					1
-8	W-105566	• Assembly, Radio Remote Control (See Group 50, Figure 08 for DET)					1
9	C-VW00587	• Assembly, Shunt (See Group 50, Figure 09 for DET)					1
10	800347	• Horn, 12V					1
11	800072	• Switch, Limit					1
12	800095	• Light, Floor Work					1

DASH (-) ITEM NOT ILLUSTRATED



CAB CONTROLS ASSEMBLY

XXT 42
PARTS
GROUP 50
FIGURE 02
PAGE 01

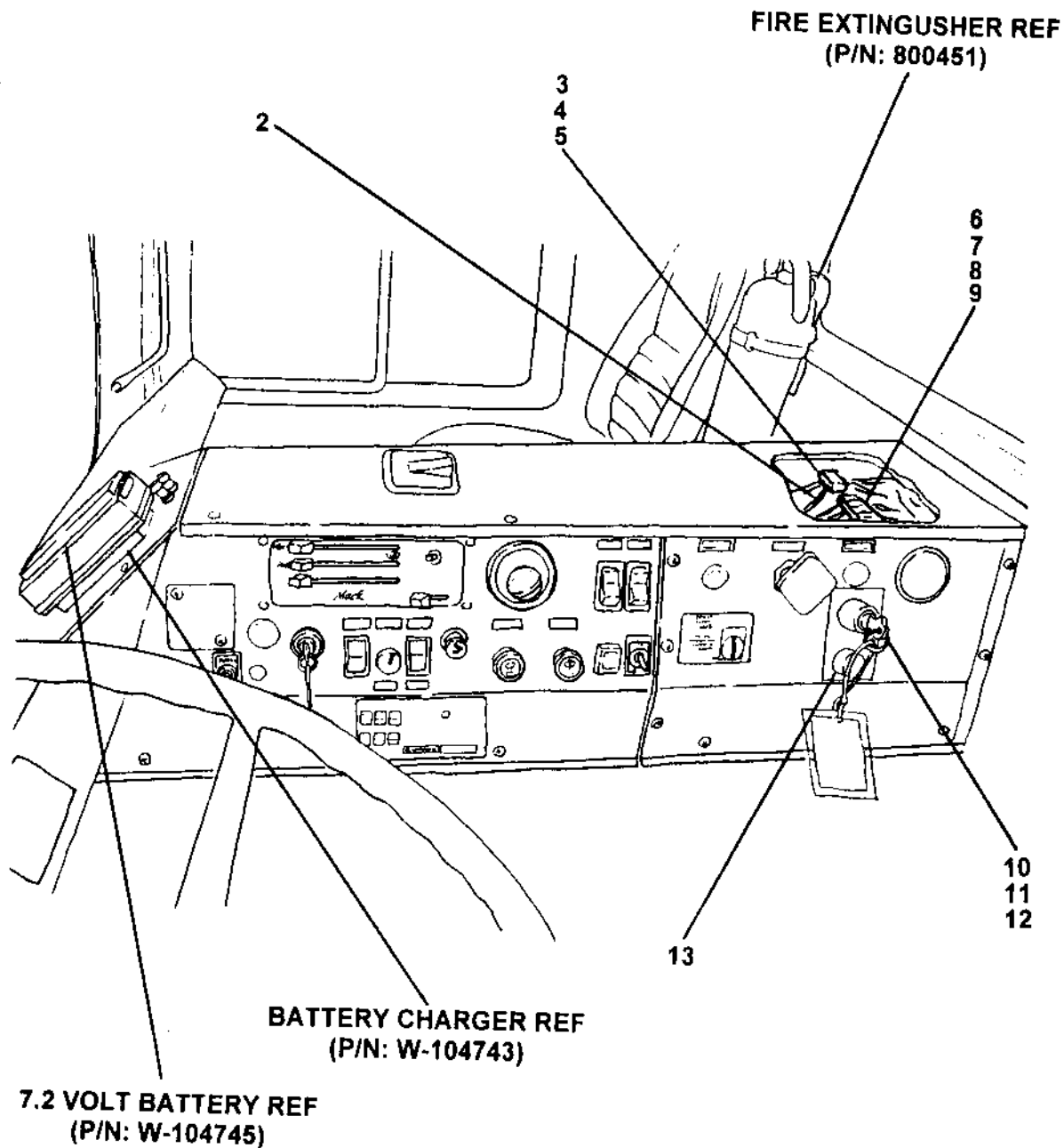

REED**CAB CONTROLS ASSEMBLY****XXT 42**
PARTS
GROUP 50
FIGURE 02
PAGE 02

ITEM NO.	REED'S PARTS NO.	DESCRIPTION					QTY
		1	2	3	4	5	
-1	800710	Assembly, Cab Controls (See Group 50, Figure 01 for NHA)					1
2	10194	• Cable, 50 FT					1
3	800433	• Block, Fuse					1
4	800448	• Fuse, ATO 20					2
5	90392	• Fuse, ATO 5					1
6	72820	• Terminal					13
7	75654	• End, Barrier					1
8	72821	• Rail, Terminal					1
9	72824	• Jumper					3
10	800369	• Operator, Key					1
11	800370	• Block, Contact					1
12	800864	• Block, Contact					2
13	800414	• Light, Green Pilot					1
-14	800965	• Switch, Pressure (Located Near Engine)					1
-15	800909	• Switch, Clutch Limit (Located under Clutch Pedal)					1

DASH (-) ITEM NOT ILLUSTRATED

MAIN CONTROLS ASSEMBLY

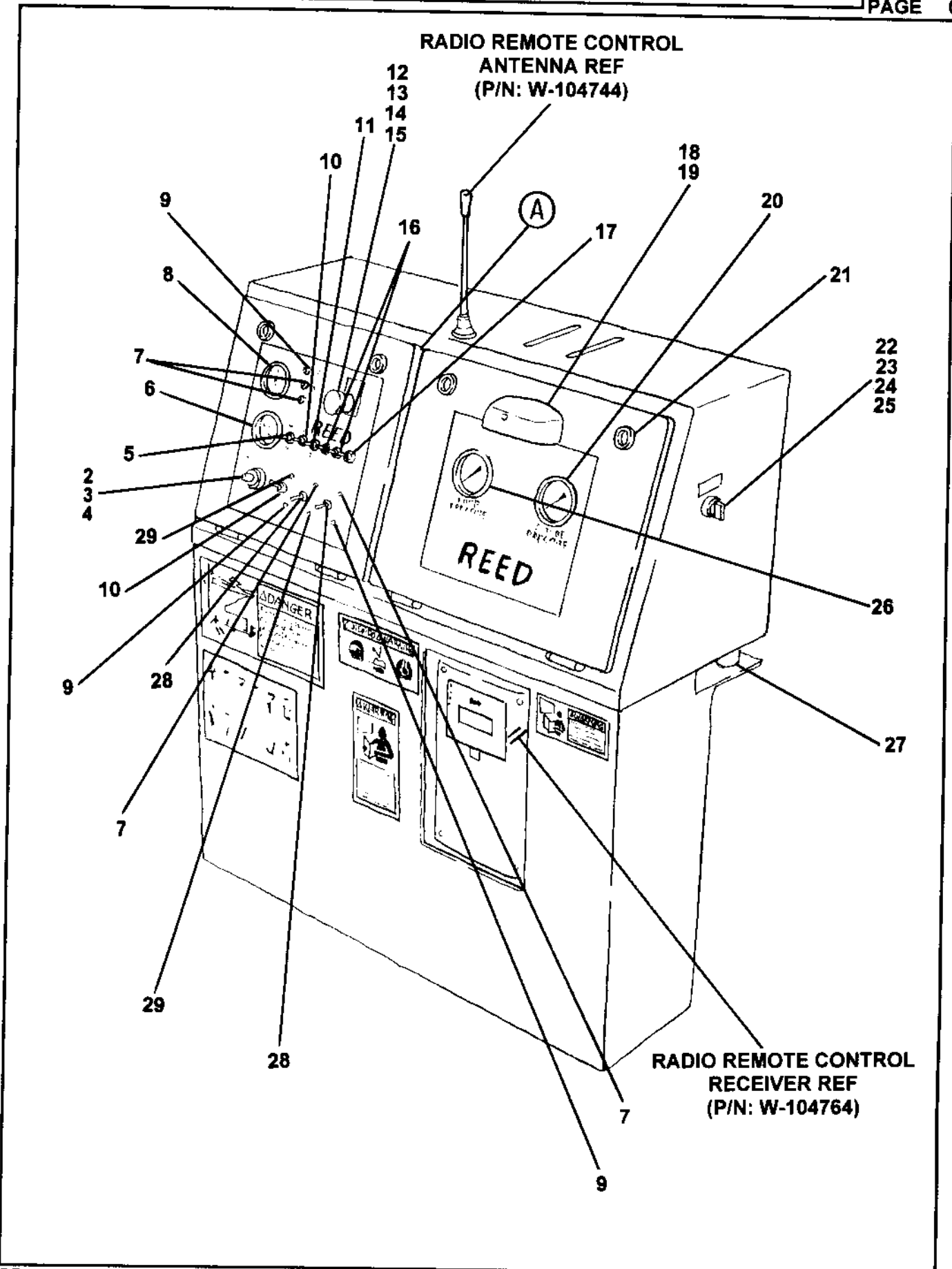



MAIN CONTROLS ASSEMBLY

XXT 42
PARTS
GROUP 50
FIGURE 03
PAGE 02

ITEM NO.	REED'S PARTS NO.	DESCRIPTION					QTY
		1	2	3	4	5	
-1	50-03	Assembly, Main Controls (See Group 50, Figure 01 for NHA)					Ref
2		• Assembly, Volume Control					1
3	W-104103	• • Potentiometer					1
4	W-104104	• • Body, Mounting					1
5	W-103976	• Switch, RPM Toggle					1
6	W-100900	• Meter, Hour					1
7	W-105811	• Light, Red Indicator					4
8	W-105823	• Thermometer					1
9	W-105813	• Light, Green Indicator					3
10	W-104090	• Switch, Vibrator / Pump Rev Toggle					2
11	W-104089	• Switch, Light / S-Tube / Pump Rev Toggle					3
12	W-105094	• Button, Emergency Stop					1
13	W-105095	• Element, Emergency Stop Contact					1
14	W-102278	• Nameplate, Emergency Stop					1
15	W-104083	• Light, Emergency					1
16	W-104091	• Switch, Lube / Horn Toggle					1
17	W-104089	• Switch, Lever					1
18	W-101033	• Assembly, Light					1
19	W-104101	• • Bulb, Replacement					1
20	70366	• Gauge, 3000 PSI Pressure					1
21		• Lock, Twist					4
22	W-100968	• Switch, A & B Momentary Rotary					1
23	W-100969	• Contact, A & B Switch					3
24	W-103735	• Bridge, A & B Switch					1
25	W-100287	• Base, A & B Switch					1
26	79831	• Gauge, 6000 PSI Pressure					1
27		• Mount, Rubber					A/R
28	72826	• Switch, On - On					1
29	W-105812	• Light, Yellow Indicator					2

DASH (-) ITEM NOT ILLUSTRATED

MAIN CONTROLS ASSEMBLY

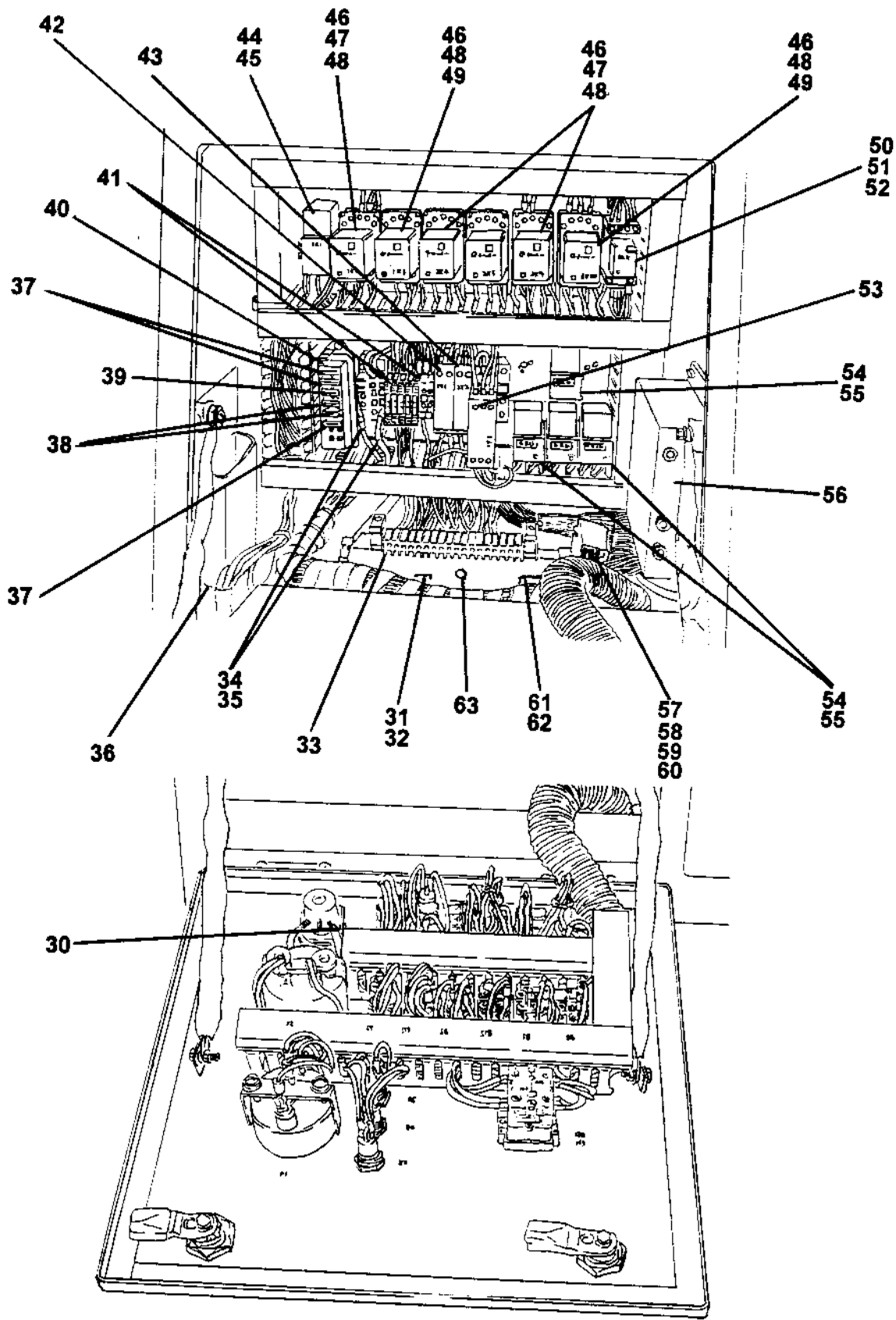

ITEM NO.	REED'S PARTS NO.	DESCRIPTION					QTY
		1	2	3	4	5	
30	W-104118	• Resistor, 100 OHM					1
31	W-100710	• Contact, 24 Pin Female (A)					1
32	W-101553	• Contact, 24 Pin Housing (A)					1
33	W-102577	• Block, Terminal					1
34	W-105817	• Clamp					2
35	W-105818	• Plate, End					2
36	W-104099	• Bag, Circuit Diagram					1
37	W-101921	• Fuse, 10 AMP					3
38	W-104096	• Fuse, 20 AMP					2
39	W-101922	• Fuse, 5 AMP					1
40	W-101577	• Holder, 8 Type Fuse					1
41	W-104185	• Diode					4
42	W-105331	• Relay, Time					1
43	W-105815	• Relay					1
44	W-105619	• Socket, Relay					1
45	W-104122	• Relay					1
46	W-104094	• Clip					6
47	W-100178	• Clip					4
48	W-104093	• Relay					6
49	W-104895	• Clip					2
50	W-103974	• Socket, Relay					1
51	W-105046	• Relay, Type 55.34					1
52	W-104860	• Clip					1
53	W-105814	• Element, Emergency Stop					1
54	W-100986	• Socket, Relay Bosch					4
55	W-104117	• Relay, Bosch					4
56	800461	• Box, Black					1
57	W-103693	• Contact, 8 Pin Female (C)					1
58	W-105816	• Contact, 8 Pin Housing (C)					1
59	W-103695	• Contact, Crimp (C)					1
60	W-103697	• Contact, Crimp (C)					1
61	W-104022	• Contact, 16 Pin Female (B)					1
62	W-104097	• Contact, 16 Pin Housing (B)					1
63	W-104669	• Condenser					1

DASH (-) ITEM NOT ILLUSTRATED

REED

DRIVER SIDE (LEFT HAND) OUTRIGGER CONTROLS ASSEMBLY

XXT 42
PARTS
GROUP 50
FIGURE 04
PAGE 01

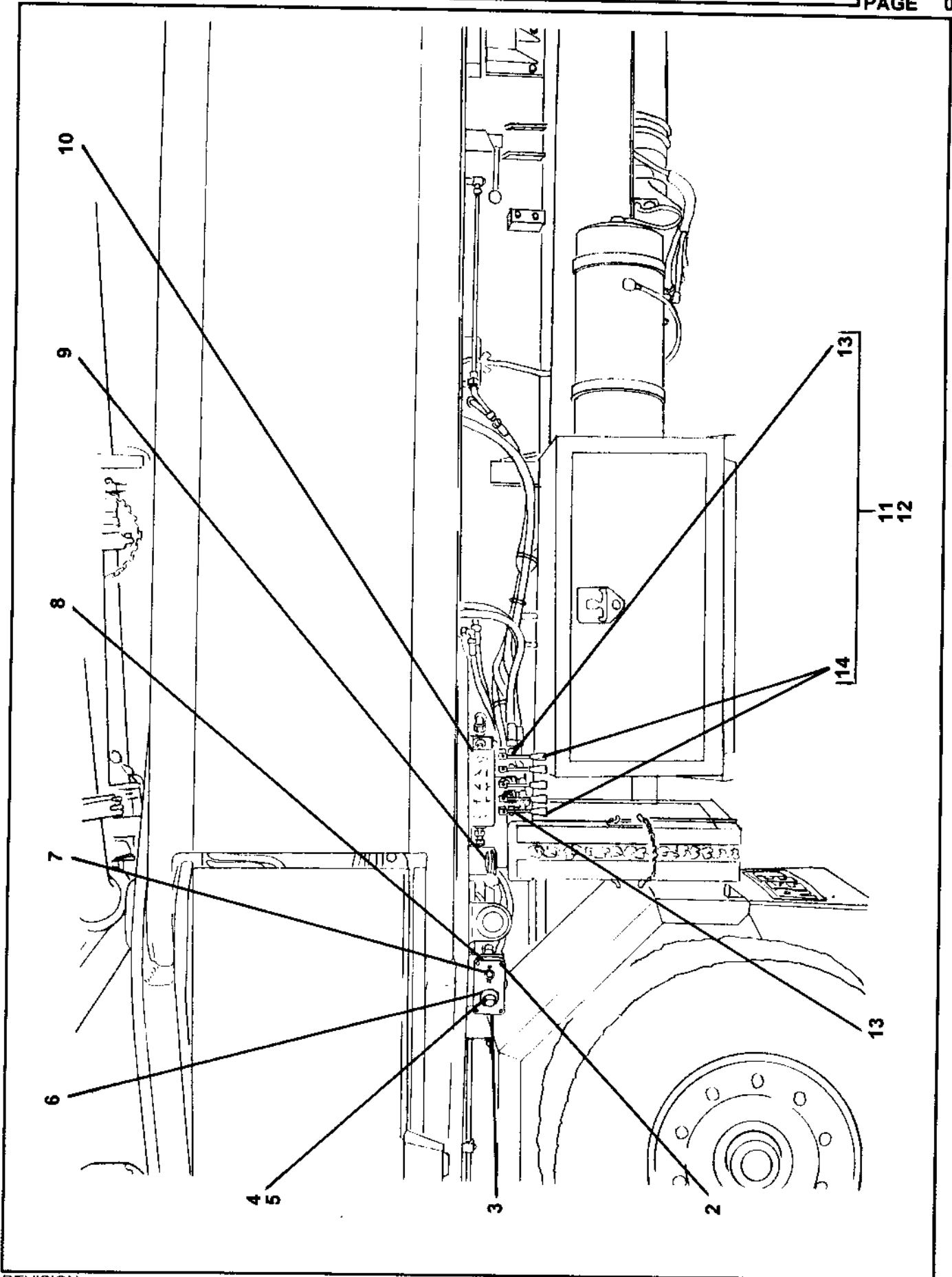

REVISION:

**DRIVER SIDE (LEFT HAND)
OUTRIGGER CONTROLS ASSEMBLY**

ITEM NO.	REED'S PARTS NO.	DESCRIPTION	QTY
-1	50-04	Assembly, Driver (L. H.) Side Outrigger Controls (See Group 50, Figure 01 for NHA)	Ref
2	W-103735	• Screw, Twist Lock Spring (attaching parts)	4
3		• Box, Non-Keyed Junction	1
4	W-104079	• Button, Emergency Stop	1
5	W-101712	• Contact, Emergency Stop Element	1
6	W-102278	• Nameplate, Emergency	1
7	W-100569	• Button, Push Operation	1
8		• Decal, Non-Keyed Junction Box	1
9	800099	• Level, Bubble	1
10	C-9V112	• Decal, Left Side Stabilizers	1
11	C-DD009	• Bank, Left Side Directional Valve	1
12		•• Lever	5
13		••• Lever, Knob	1
14		••• Boot, Rubber	1

DASH (-) ITEM NOT ILLUSTRATED

REED

PASSENGER SIDE (RIGHT HAND) OUTRIGGER CONTROLS ASSEMBLY

XXT 42
PARTS
GROUP 50
FIGURE 05
PAGE 01

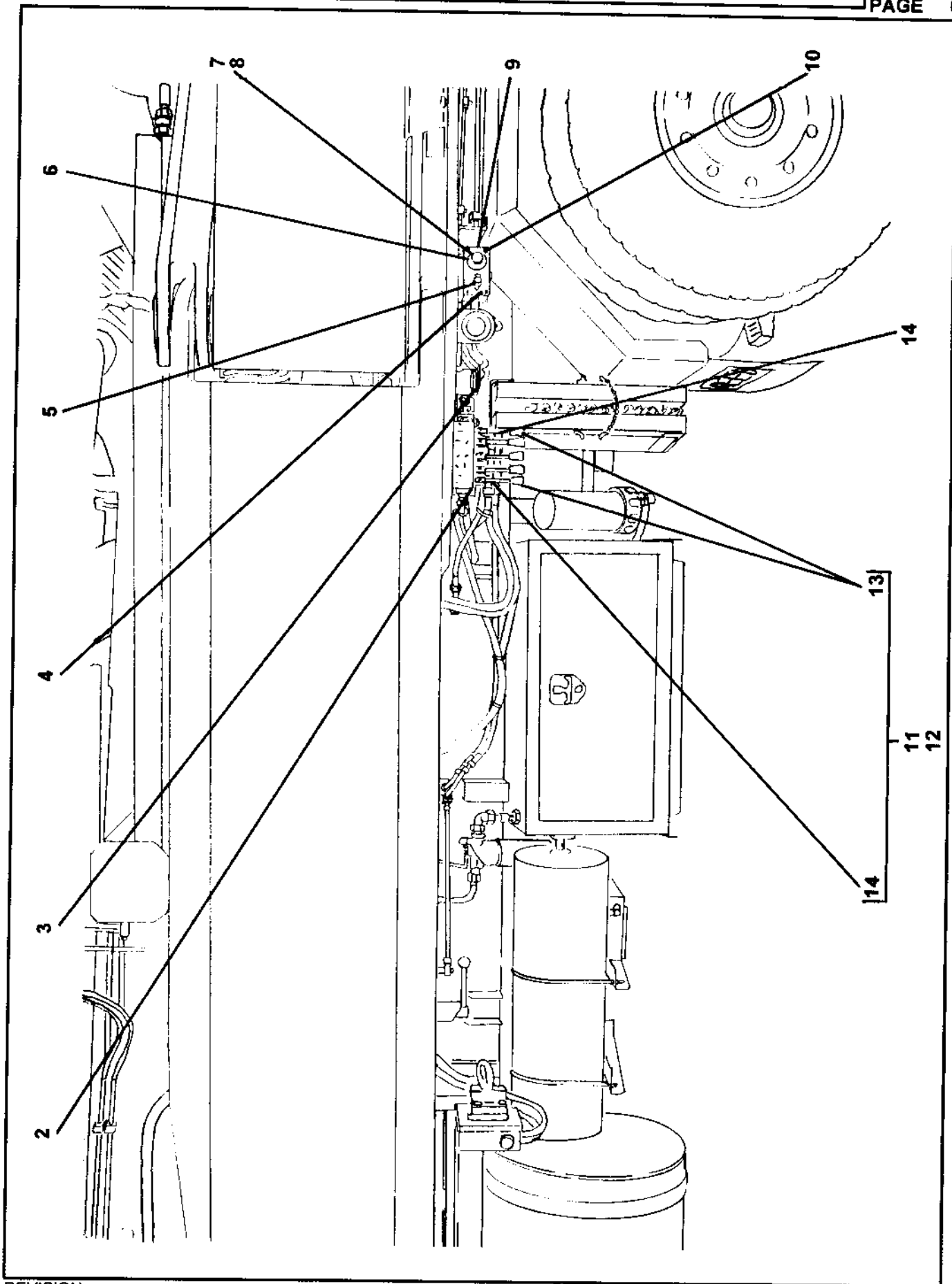

REVISION:



**PASSENGER SIDE (RIGHT HAND)
OUTRIGGER CONTROLS ASSEMBLY**

**XXT 42
PARTS
GROUP 50
FIGURE 05
PAGE 02**

ITEM NO.	REED'S PARTS NO.	DESCRIPTION					QTY
		1	2	3	4	5	
-1	50-05	Assembly, Passenger (R. H.) Side Outrigger Controls (See Group 50, Figure 01 for NHA)					Ref
2	C-9V111	• Decal, Right Side Stabilizers					1
3	800099	• Level, Bubble					1
4		• Decal, Keyed Junction Box					1
5	W-100569	• Button, Push Operation					1
6	W-102278	• Nameplate, Emergency					1
7	W-104079	• Button, Emergency Stop					1
8	W-101712	• Contact, Emergency Stop Element					1
9		• Box, Keyed Junction					1
10	W-103735	• Screw, Twist Lock Spring (attaching parts)					4
11	C-DD009	• Bank, Right Side Directional Valve					1
12		• • Lever					5
13		• • • Lever, Knob					1
14		• • • Boot, Rubber					1

DASH (-) ITEM NOT ILLUSTRATED

STATIONARY BOOM CONTROLS ASSEMBLY

XXT 42
PARTS
GROUP 50
FIGURE 06
PAGE 01

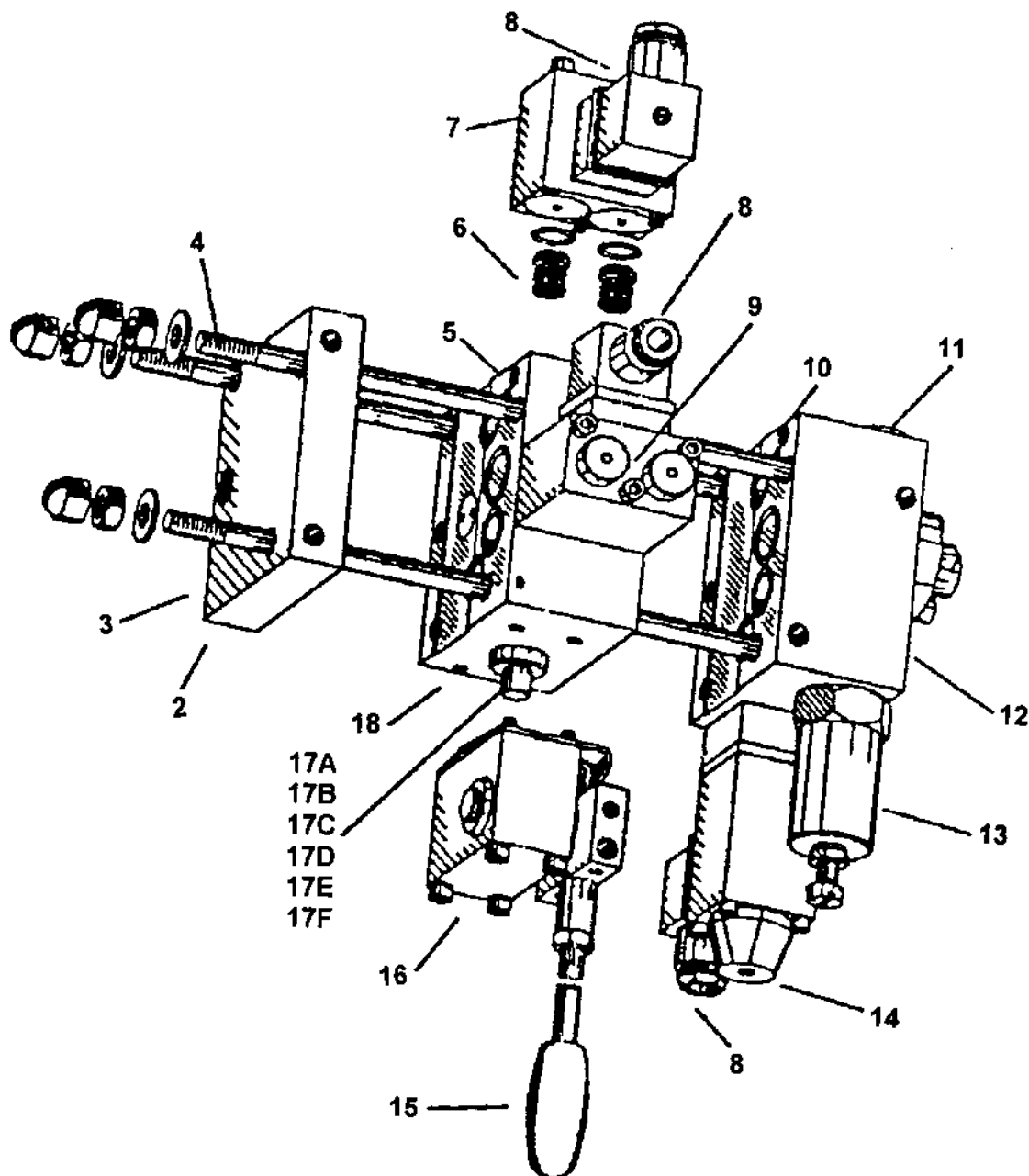

ITEM NO.	REED'S PARTS NO.	DESCRIPTION					QTY
		1	2	3	4	5	
-1	W-106710	Assembly, Stationary Boom Controls (See Group 50, Figure 01 for NHA)					Ref
2		• Plate, End					1
3		• Valve, Check					1
4		• Set, Tension Rod					1
5		• Kit, Valve Section Seal					6
6		• Valve, Press Reducing					6
7		• Solenoid, Actuation					6
8		• Plug, Solenoid					13
9		• Solenoid, Function					6
10		• Kit, Connection Block Seal					1
11		• Valve, Pilot Press Reducing					1
12		• Block, Connection					1
13		• Valve, Pressure Limiting					1
14		• Valve, Directional Seated					1
15		• Lever, Hand					6
16		• Housing, Actuation					6
17A	801622	• Spool , Boom A (63/63)					1
17B	801622	• Spool , Boom B (63/63)					1
17C	801271	• Spool , Boom C (40/40)					1
17D	801272	• Spool , Boom D (25/25)					1
17E	801271	• Spool , Outrigger (40/40)					1
17F	801271	• Spool , Rotation (40/40)					1
18		• Valve, Section					6
-19	C-4V120	• Decal, Control					1

DASH (-) ITEM NOT ILLUSTRATED

REED

CABLED REMOTE CONTROL ASSEMBLY

XXT 42
PARTS
GROUP 50
FIGURE 07
PAGE 01

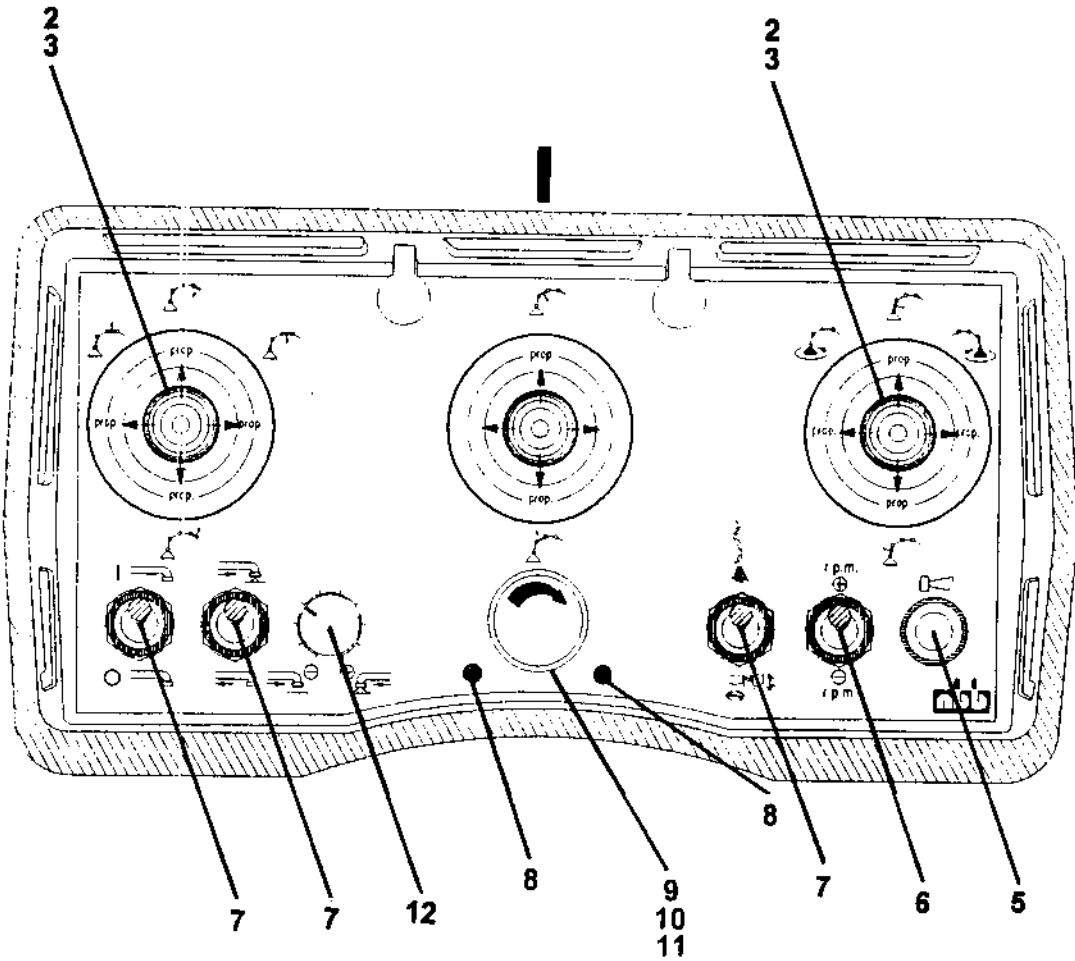



CABLED REMOTE CONTROL ASSEMBLY

XXT 42
PARTS
GROUP 50
FIGURE 07
PAGE 02

ITEM NO.	REED'S PARTS NO.	DESCRIPTION					QTY
		1	2	3	4	5	
-1	W-105565	Assembly, Cabled Remote Control (See Group 50, Figure 01 for NHA)					Ref
2		• Switch, Joy Stick Control					3
3		• • Boot, Rubber					3
-4		• Strap, Shoulder					1
5	3.740.1020	• Switch, O - Mom Push Button					1
6	3.740.1017	• Switch, Mom - O - Mom Toggle					1
7	3.740.1018	• Switch, On - O - On Toggle					3
8		• • Indicator, Light					2
9		• • Switch, Emergency Stop					1
10		• • • Knob, with Key					1
11		• • • Switch, Contact					1
12	3.980.1156	• • Potentiometer, with Knob					1

DASH (-) ITEM NOT ILLUSTRATED

REED

RADIO REMOTE CONTROL ASSEMBLY

XXT 42
PARTS
GROUP 50
FIGURE 08
PAGE 01

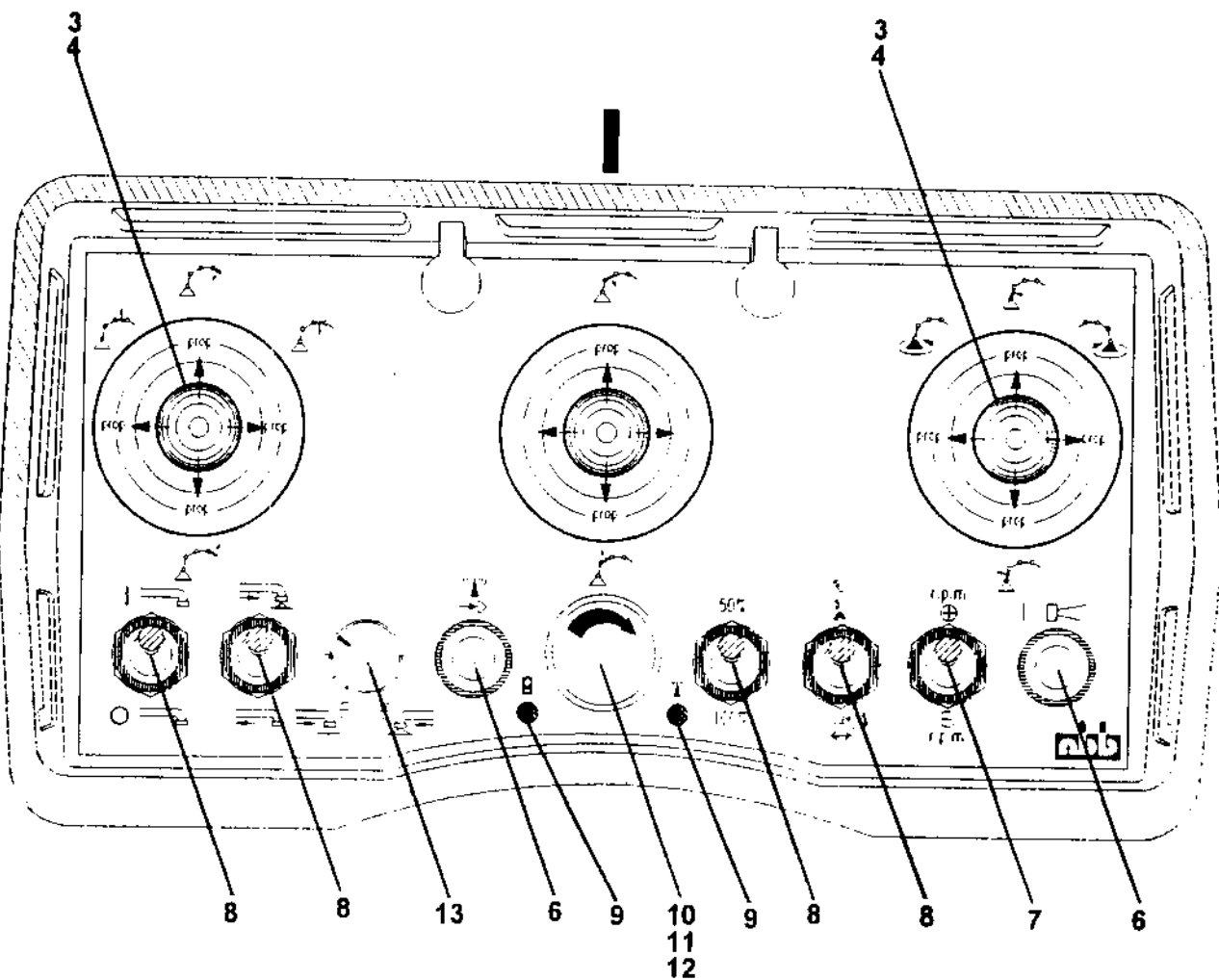
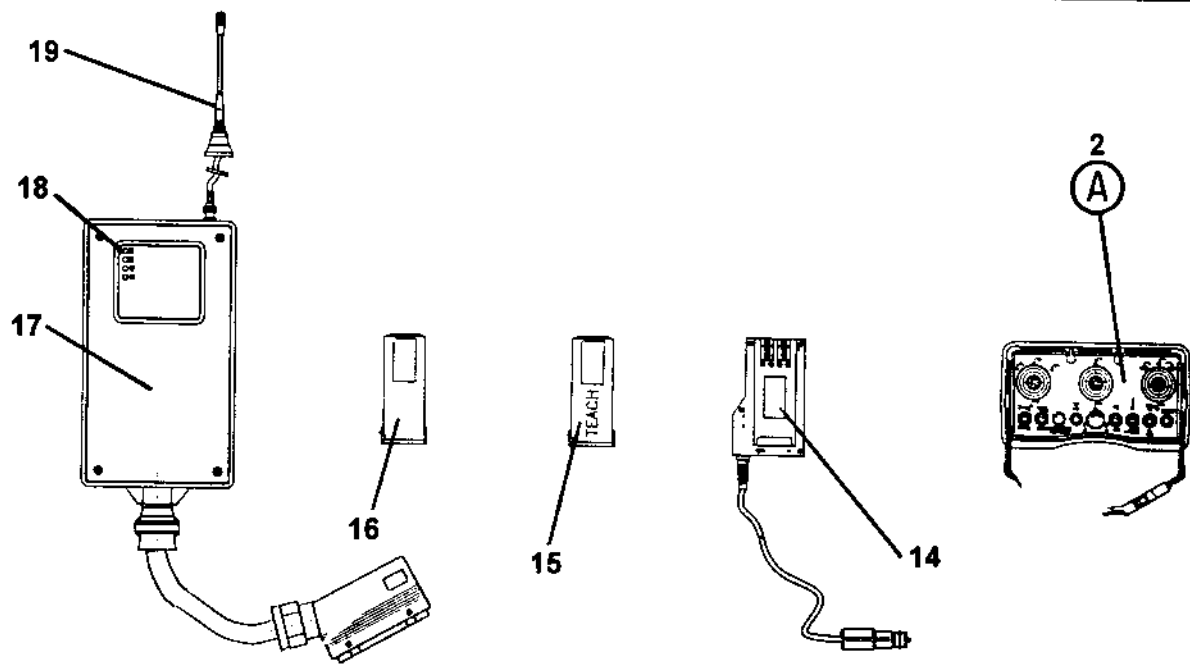

(A)

ITEM NO.	REED'S PARTS NO.	DESCRIPTION					QTY
		1	2	3	4	5	
-1	W-105566	Assembly, Radio Remote Control (See Group 50, Figure 01 for NHA)					Ref
2	W-104763	• Transmitter, Radio Remote Control					1
3		• • Switch, Joy Stick Control					3
4		• • • Boot, Rubber					1
-5		• • Strap, Shoulder					1
6	3.740.1020	• • Switch, O – Mom Push Button					1
7	3.740.1017	• • Switch, O – Mom Toggle					1
8	3.740.1018	• • Switch, On – O - On Toggle					4
9		• • Indicator, Light					2
10		• • Switch, Emergency Stop					1
11		• • • Knob, with Key					1
12		• • • Switch, Contact					1
13	3.980.1156	• • Potentiometer, with Knob					1
14	W-104743	• Charger, Battery (See Group 50, Figure 02 for REF)					1
15	W-104430	• Battery, Teach					1
16	W-104745	• Battery, 7.2V (See Group 50, Figure 02 for REF)					1
17	W-104764	• Receiver, Radio Remote Control (See Group 50, Figure 03 for REF)					1
18		• • Indicator, Light					5
19	W-104774	• Antenna, Radio Remote Control (See Group 50, Figure 03 for REF)					1

DASH (-) ITEM NOT ILLUSTRATED

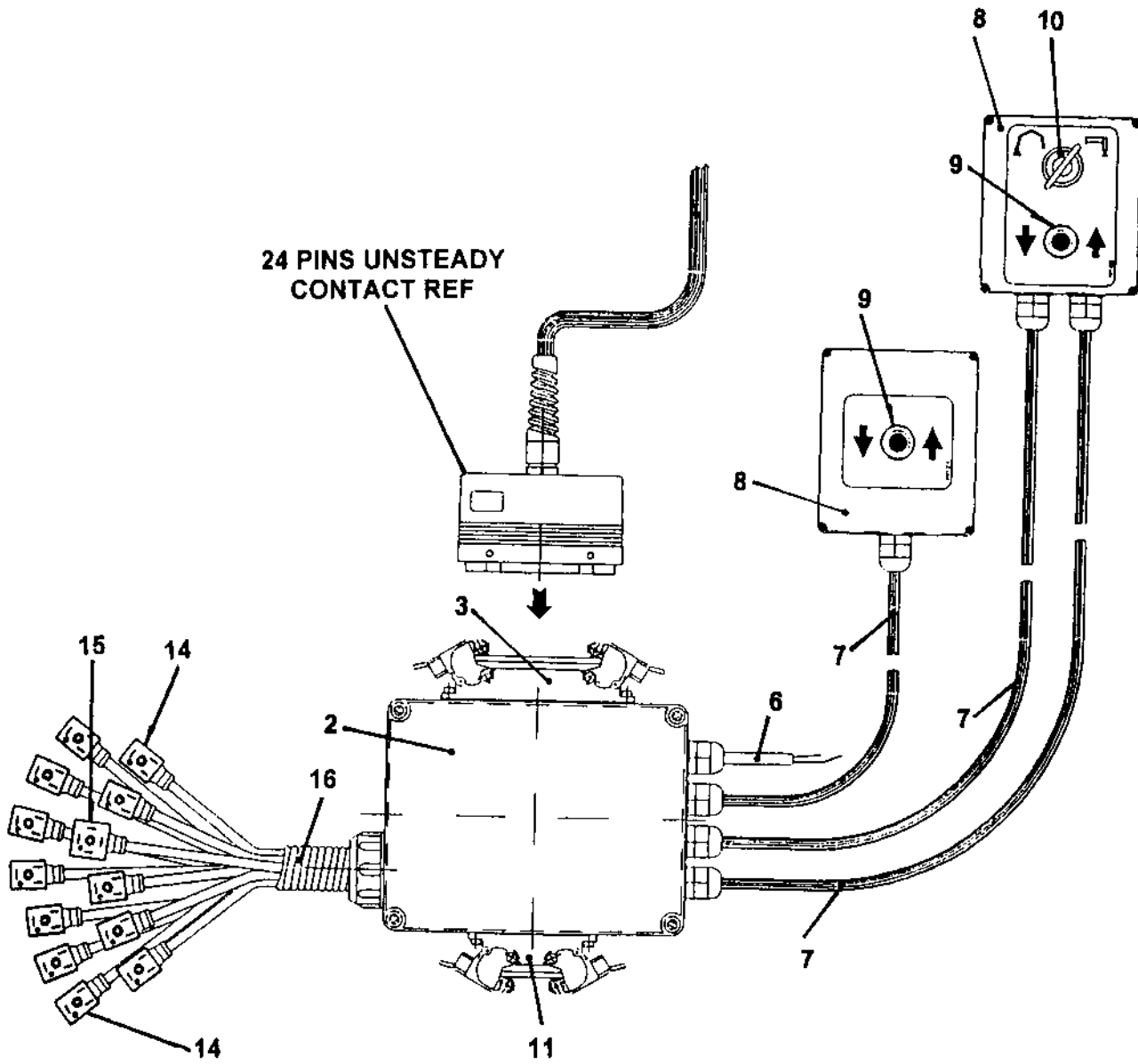

REED**SHUNT ASSEMBLY****XXT 42**
PARTS
GROUP 50
FIGURE 09
PAGE 02

ITEM NO.	REED'S PARTS NO.	DESCRIPTION					QTY
		1	2	3	4	5	
-1	C-VW00587	Assembly, Shunt (See Group 50, Figure 01 for NHA)					Ref
2	C-WW00230	• • Box, Connector 214 X 162 X 92					1
3		• • Plug, 24 Points Contact					1
-4	C-WW00154	• • • Plug					1
-5	C-WW00167	• • • Case, Plug					1
6	C-WW00116	• • Cable, Electric 1.6 m					1
7	C-WW00265	• • Cable, Electric 4 m					3
8	C-ES001	• • Box, Junction					2
9	C-EI001	• • Switch					2
10	C-WW00190	• • Switch, 2 Position Key					1
11		• • Plug, 10 Points Auxiliary Contact					1
-12	C-WW00011	• • • Plug					1
-13	C-WW00037	• • • Case, Plug					1
14	C-WW00065	• • Plug, Rectangular with Cable					12
15	C-WW00175	• • Plug, Square with Electric Cable					1
16	C-WW00100	• • Cable, 1.5 m Sheath					1

DASH (-) ITEM NOT ILLUSTRATED

REVISION:



MODEL XXT 42 TRUCK MOUNTED
CONCRETE BOOM PUMP
ILLUSTRATED PARTS MANUAL

XXT 42
PARTS
GROUP 50
FIGURE 10
PAGE 01

THIS PAGE INTENTIONALLY LEFT BLANK.



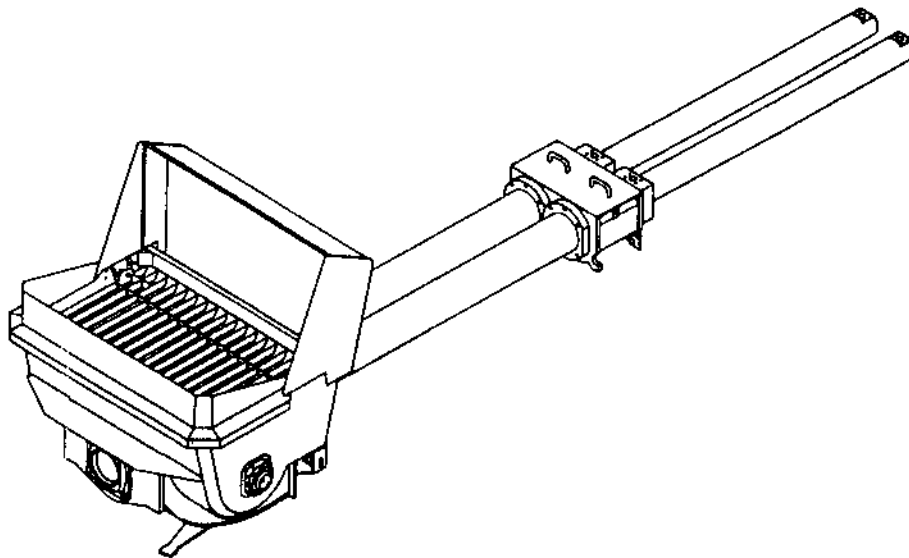

**REED TRUCK MOUNTED CONCRETE BOOM PUMP MODEL XXT 42
ILLUSTRATED PARTS MANUAL GROUP 60 PUMPING TRAIN INSTALLATION
CONTAINS THE FOLLOWING FIGURES:**

FIGURE 00	TABLE OF CONTENTS
FIGURE 01	PUMPING TRAIN INSTALLATION
FIGURE 02	SWING VALVE ASSEMBLY
FIGURE 03	TILTING DRIVE ASSEMBLY
FIGURE 04	TILTING CYLINDER ASSEMBLY
FIGURE 05	CONCRETE CYLINDER ASSEMBLY
FIGURE 06	WATER BOX ASSEMBLY
FIGURE 07	HYDRAULIC DRIVE CYLINDER ASSEMBLY
FIGURE 08	DRIVE CYLINDER SUB-ASSEMBLY

REED

PUMPING TRAIN INSTALLATION

XXT 42
PARTS
GROUP 60
FIGURE 01
PAGE 01

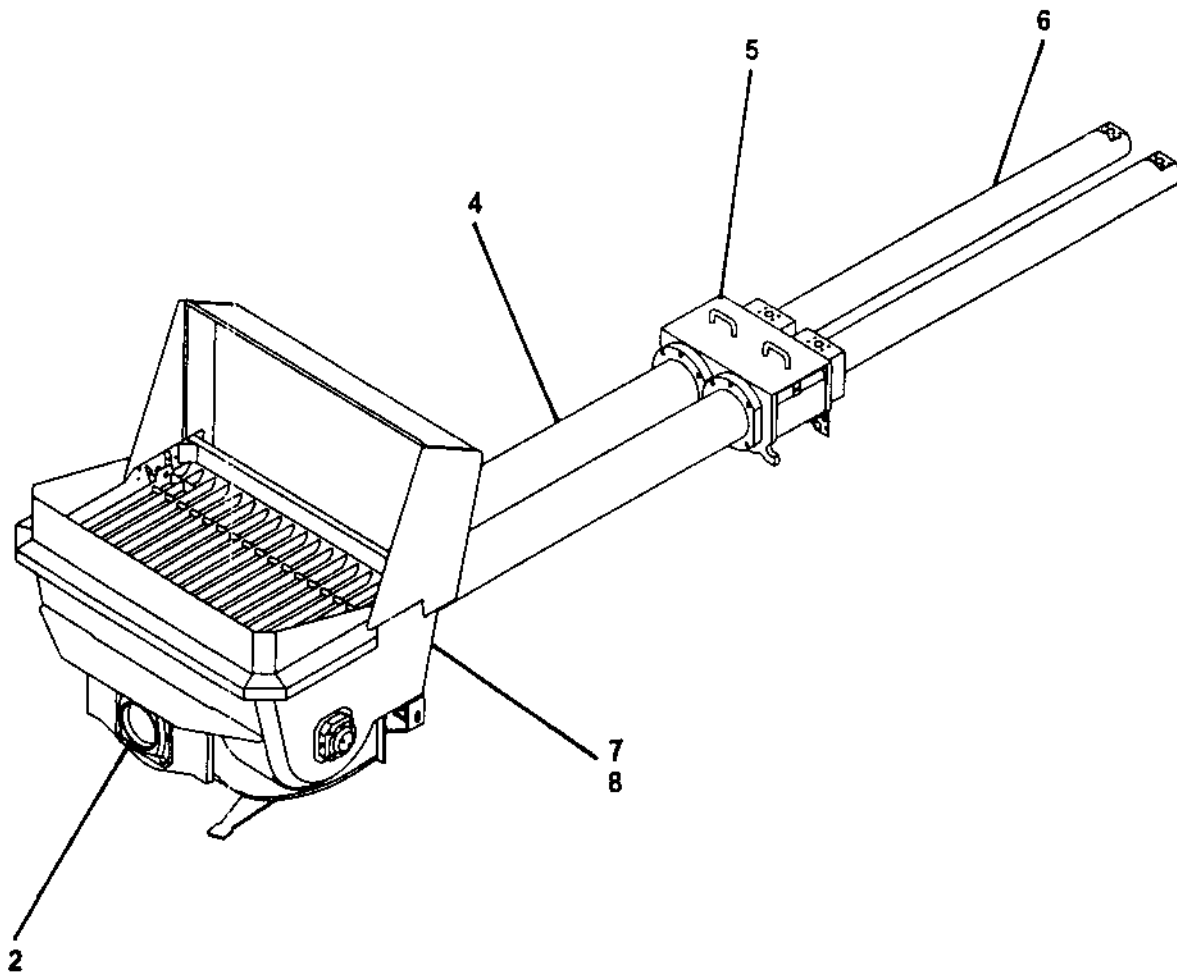

ITEM NO.	REED'S PARTS NO.	DESCRIPTION					QTY
		1	2	3	4	5	
-1	60-01	Installation, Pumping Train (See Group 10, Figure 01 for NHA)					Ref
2	B-174090	• Assembly, Swing Valve (See Group 60, Figure 02 for DET)					1
-3	B-174130	• Assembly, Tilting Drive (See Group 60, Figure 03 for DET)					1
4	B-124017	• Assembly, Concrete Cylinder (See Group 60, Figure 05 for DET)					1
5	B-143000	• Assembly, Water Box (See Group 60, Figure 06 for DET)					1
6	60-06	• Assembly, Hydraulic Drive Cylinder (See Group 60, Figure 07 for DET)					1
7	20-01	• Installation, Hopper (See Group 20, Figure 01 for REF)					Ref
-8	B-183000	• System, Central Lubrication (See Group 20, Figure 02 for REF)					Ref

DASH (-) ITEM NOT ILLUSTRATED



SWING VALVE ASSEMBLY

XXT 42
PARTS
GROUP 60
FIGURE 02
PAGE 01

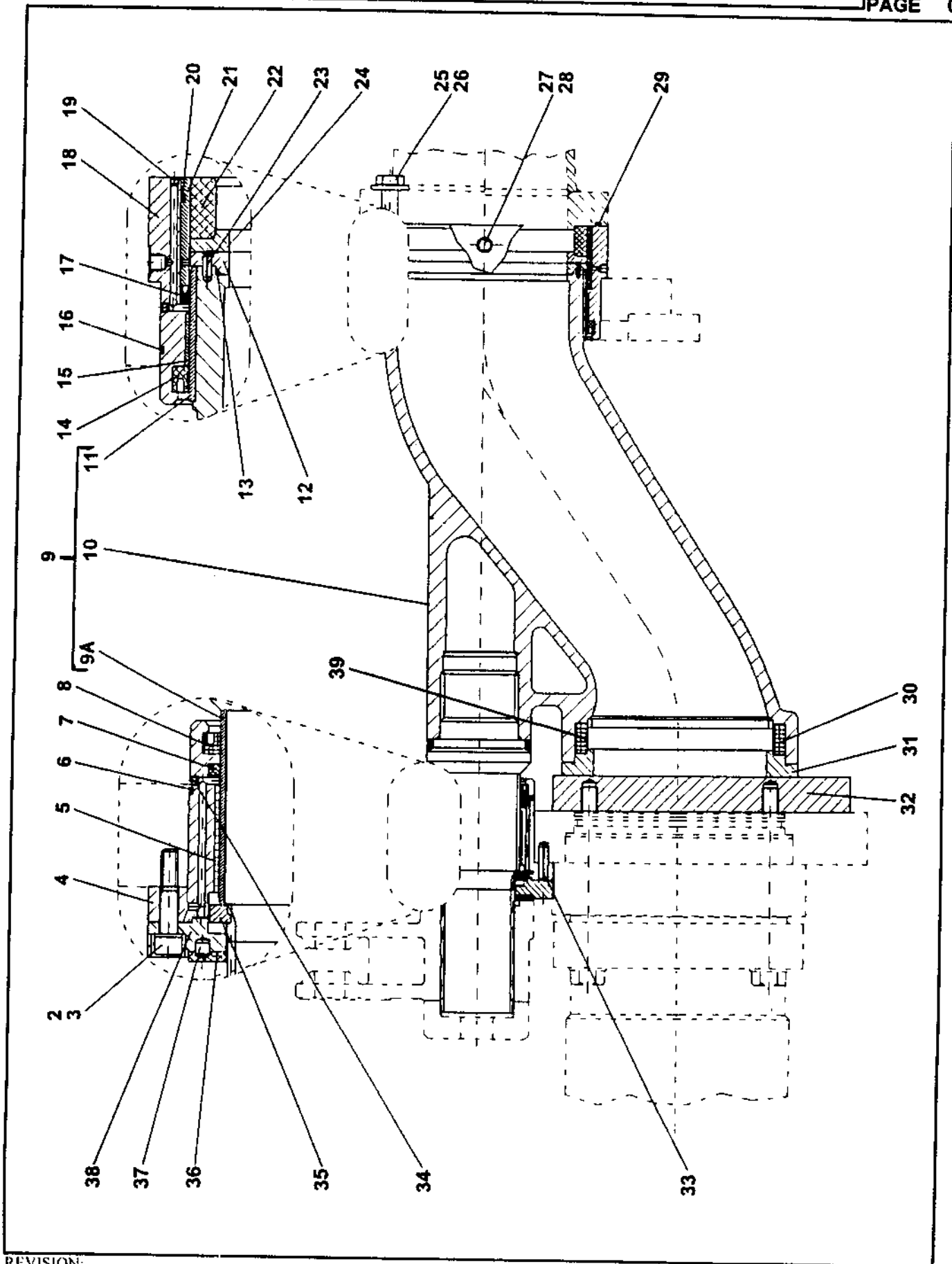

REVISION:

	REED'S PARTS NO.	1 2 3 4 5	DESCRIPTION	QTY
-1	B-174090		Assembly, Swing Valve (See Group 60, Figure 01 for NHA)	Ref
2	W-103151	•	Screw, M12	3
3	W-103113	•	Washer, Spring A12	3
4	B-174024	•	Housing, Small Bearing	1
5	W-100237	•	Bushing	1
6	W-100486	•	O-Ring	2
7	W-100485	•	O-Ring	2
8	B-173077	•	Ring, Groove	1
9	W-105223	•	Assembly, Swing Tube	1
9A	B-172105	• •	Bushing, Small	1
10	B-174089	• •	Valve, Swing DN 200	1
11	B-172107	• •	Bushing, Big	1
12	B-174027	•	Ring, Sliding	1
13	W-100625	•	O-Ring	1
14	B-173078	•	Ring, Groove	1
15	W-100236	•	Ring, Outlet Wear	1
16	W-100481	•	O-Ring	1
17	W-103078	•	Foreseal	1
18	B-174022	•	Housing, Big Bearing	1
19	W-100499	•	Screw, M5 Set	2
20	W-103365	•	O-Ring	1
21	B-174023	•	Ring, Spacer	1
22	W-100262	•	Ring, Outlet Wear	1
23	W-103077	•	Pin, Spring Type Straight	2
24	B-174028	•	Ring, Sliding	1
25	W-101589	•	Screw, M20 Hex	4
26	W-102110	•	Washer, A20	4
27	W-101621	•	Screw, M8 Hex	1
28	W-101269	•	Ring	1
29	W-101588	•	O-Ring	1
30	W-103378	•	Ring, Wear Ring Tension	1
31	B-174087	•	Ring, Wear	1
32	B-174091	•	Plate, Wear	1
33	W-103076	•	Pin, Spring Type Straight	1
34	W-102710	•	Screw, M4 Set	4
35	B-174026	•	Profile	1
36	B-173012	•	Washer, Phenolic Axial Bearing	1
37	W-103080	•	Pin, Cylindrical	1
38	B-174025	•	Flange	1
39	B-174092	•	Protection, Tension Ring	1

DASH (-) ITEM NOT ILLUSTRATED

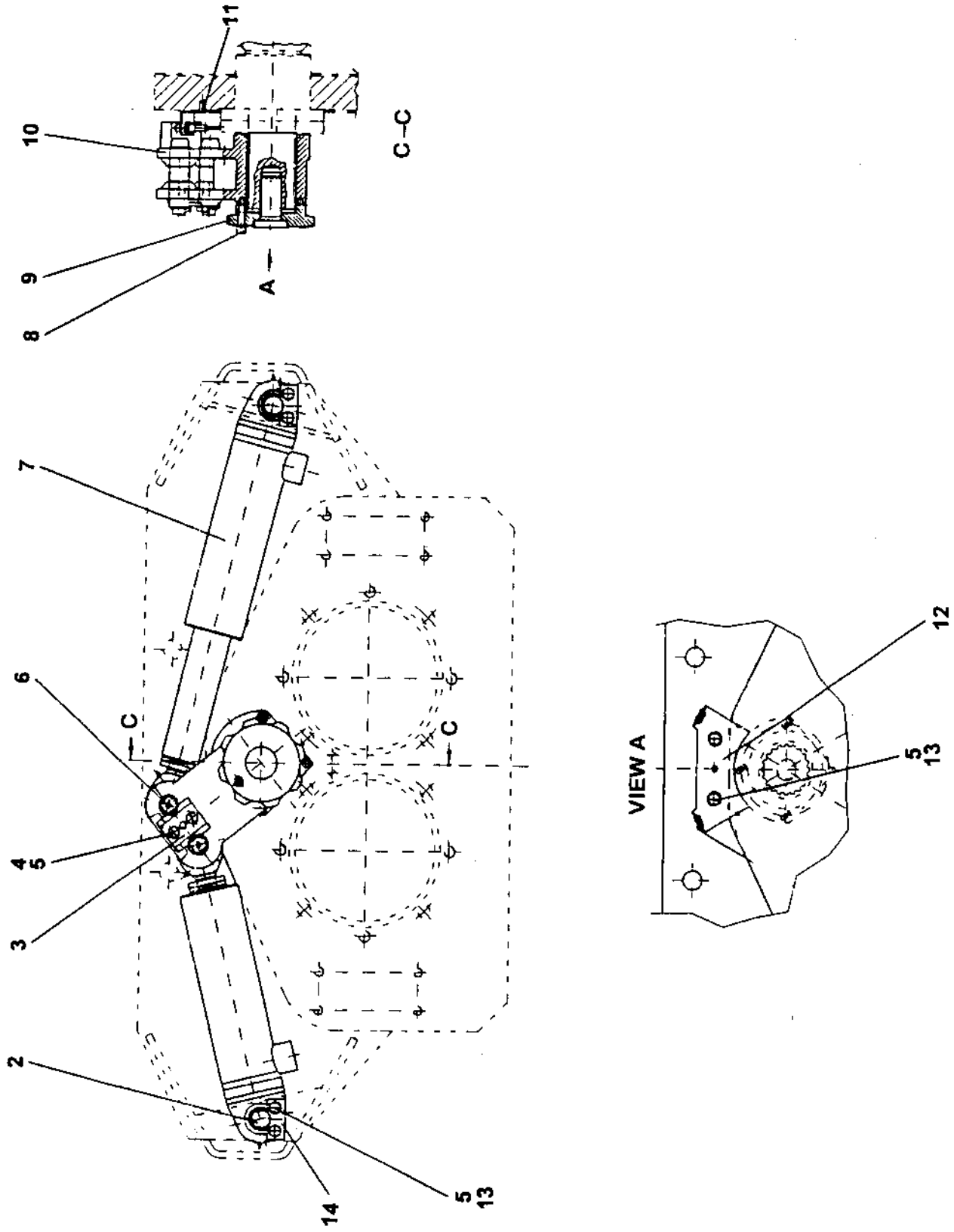

REED**TILTING DRIVE ASSEMBLY****XXT 42**
PARTS
GROUP 60
FIGURE 03
PAGE 02

ITEM NO.	REED'S PARTS NO.	DESCRIPTION					QTY
		1	2	3	4	5	
-1	B-174130	Assembly, Tilting Drive (See Group 60, Figure 01 for NHA)					Ref
2	B-173066	• Pin, Safety					2
3	B-174083	• Plate, Key					1
4	W-102107	• Screw, M12 Hex					2
5	W-102877	• Washer, A12					8
6	B-173019	• Pin					2
7	W-103363	• Assembly, Tilting Cylinder (See Group 60, Figure 04 for DET)					2
8	B-174035	• Screw, M10 Hex (attaching parts)					1
9	B-174032	• Plate, Tension					1
10	B-174031	• Lever, Tilting					1
11	W-102881	• Pin, Spring Type Straight					1
12	B-174084	• Bracket, Sensor					1
13	W-101001	• Bolt, M12					6
14	B-173067	• Plate, Safety Pin					2

DASH (-) ITEM NOT ILLUSTRATED



TILTING CYLINDER ASSEMBLY

XXT 42
PARTS
GROUP 60
FIGURE 04
PAGE 01

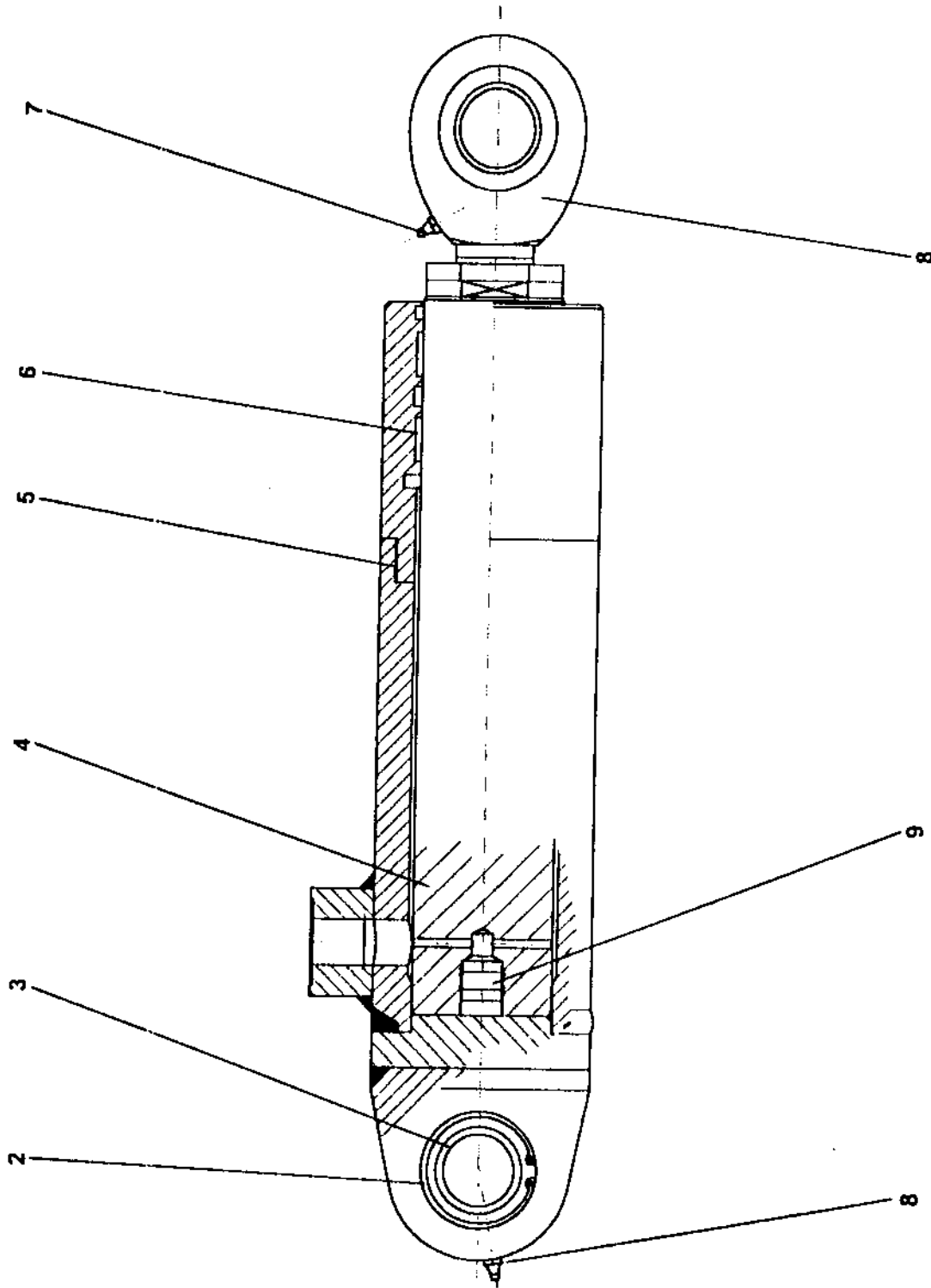



TILTING CYLINDER ASSEMBLY

XXT 42
PARTS
GROUP 60
FIGURE 04
PAGE 02

ITEM NO.	REED'S PARTS NO.	DESCRIPTION					QTY
		1	2	3	4	5	
-1	W-103363	Assembly, Tilting Cylinder (See Group 60, Figure 03 for NHA)					Ref
2	W-103626	• Bearing					1
3	W-101973	• Ring, Retaining					1
4	W-104438	• Rod, Piston					1
5	W-104440	• Pipe, Cylinder					1
6	W-103364	• Kit, Seal					1
7	W-100805	• Nipple, Grease					2
8	W-104437	• Valve, Check					1
9	W-104439	• Head, Rod					1

DASH (-) ITEM NOT ILLUSTRATED

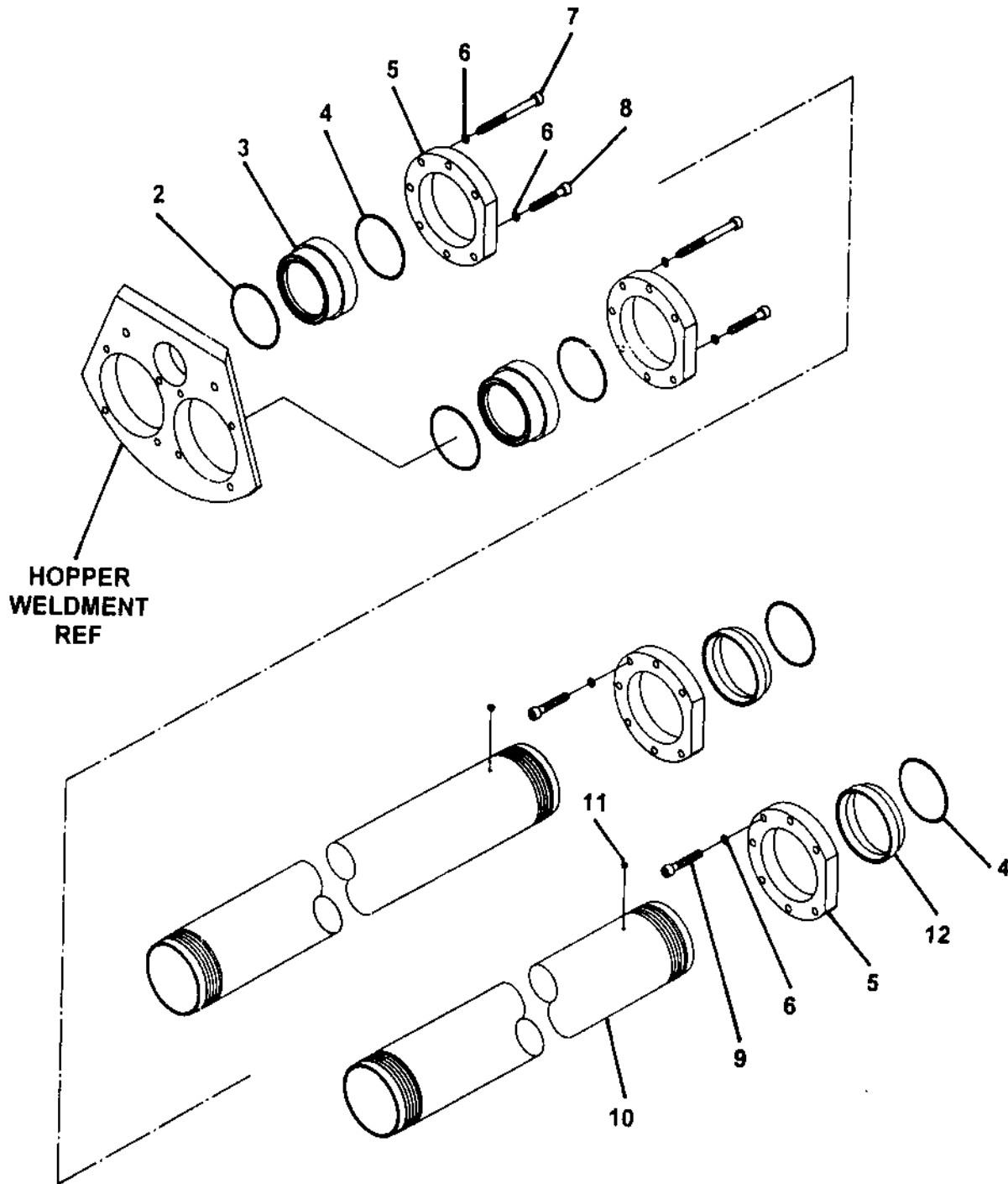

REED**CONCRETE CYLINDER ASSEMBLY****XXT 42**
PARTS
GROUP 60
FIGURE 05
PAGE 02

ITEM NO.	REED'S PARTS NO.	DESCRIPTION					QTY
		1	2	3	4	5	
-1	W-103363	Assembly, Tilting Cylinder (See Group 60, Figure 03 for NHA)					Ref
2	W-103626	• Bearing					1
3	W-101973	• Ring, Retaining					1
4	W-104438	• Rod, Piston					1
5	W-104440	• Pipe, Cylinder					1
6	W-103364	• Kit, Seal					1
7	W-100805	• Nipple, Grease					2
8	W-104437	• Valve, Check					1
9	W-104439	• Head, Rod					1

DASH (-) ITEM NOT ILLUSTRATED

REED

WATER BOX ASSEMBLY

XXT 42
PARTS
GROUP 60
FIGURE 06
PAGE 01

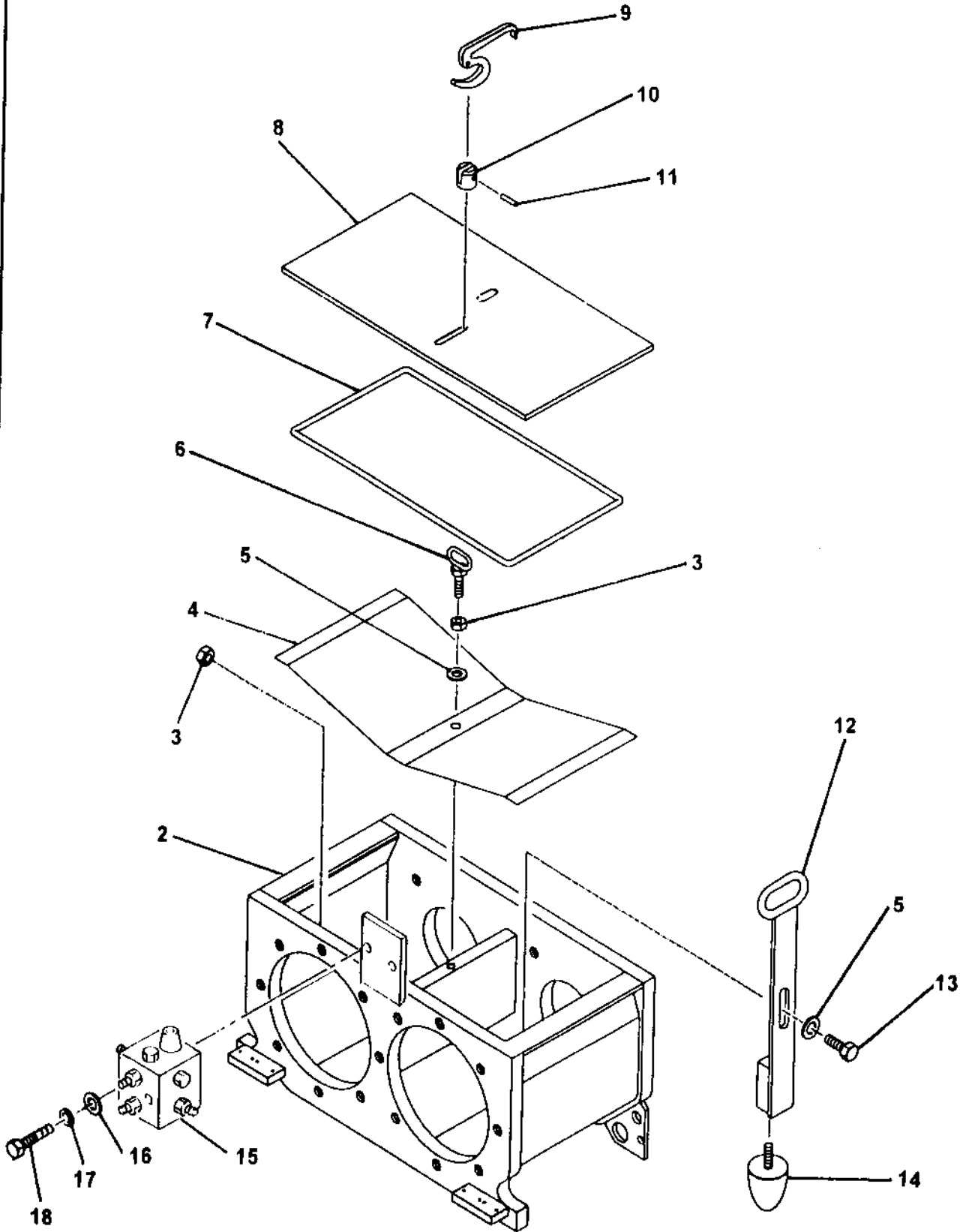

ITEM NO.	REED'S PARTS NO.	DESCRIPTION					QTY
		1	2	3	4	5	
-1	B-143000	Assembly, Water Box (See Group 60, Figure 01 for NHA)					Ref
2	B-143001	• Weldment, Water Box					1
3	W-101557	• Nut, M12 Hex					2
4	B-143020	• Cover, Safety					1
5	W-100504	• Washer					2
6	B-143009	• Bolt, M12 Eye					1
7	W-101831	• Seal, Round Cord					1
8	B-143015	• Cover, Water Box					1
9	B-143007	• Lever					1
10		• Head, Eye Bolt					1
11	W-103387	• Pin, Grooved					1
12	B-143011	• Handle					1
13	W-103688	• Bolt, M12 Hex					1
14	W-102712	• Buffer, Rubber					1
15	W-104402	• Block, Lube					1
16		• Washer, Flat (attaching parts)					2
17		• Washer, Lock (attaching parts)					2
18		• Bolt, Hex (attaching parts)					2

DASH (-) ITEM NOT ILLUSTRATED

HYDRAULIC DRIVE CYLINDER ASSEMBLY

XXT 42
PARTS
GROUP 60
FIGURE 07
PAGE 01

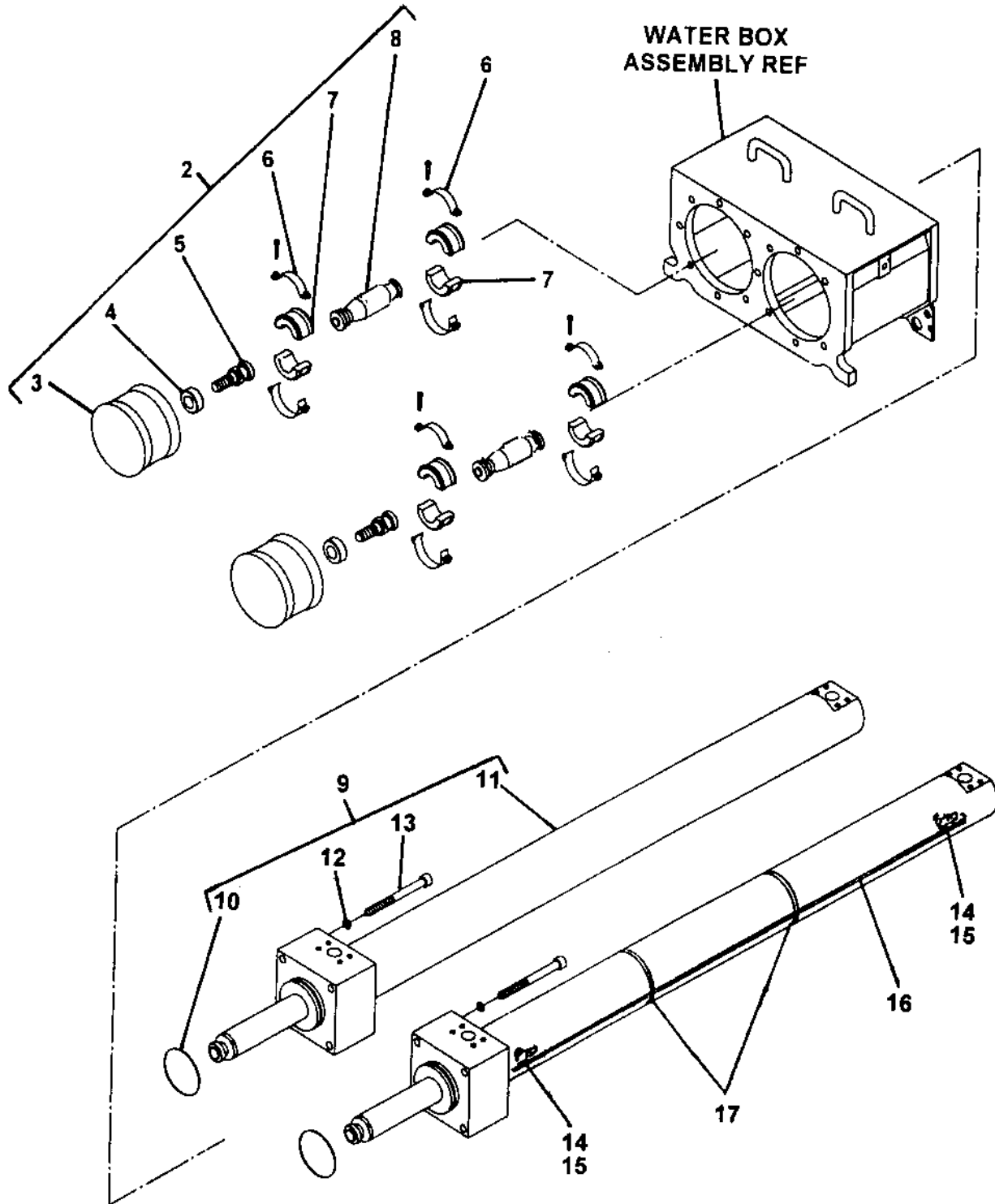

REED**HYDRAULIC DRIVE
CYLINDER ASSEMBLY****XXT 42**
PARTS
GROUP 60
FIGURE 07
PAGE 02

ITEM NO.	REED'S PARTS NO.	DESCRIPTION					QTY
		1	2	3	4	5	
-1	60-06	Assembly, Hydraulic Drive Cylinder (See Group 60, Figure 01 for NHA)					Ref
2	B-133020	• Assembly, Piston Ram					1
3	W-100175	• • Ram, Piston					2
4	B-133019	• • Ring, Protection					2
5	B-133018	• • Bolt, Coupling					2
6	W-101381	• • Clamp, Hose					4
7	B-131004	• • Coupling, Clamp					4
8	B-133003	• • Adapter, Dog Bone					2
9	B-154022	• Assembly, Hydraulic Drive Cylinder					2
10	W-101441	• • O-Ring					2
11	W-154939	• • Sub-Assembly, Hydraulic Drive Cylinder (See Group 60, Figure 08 for DET)					2
12	W-103070	• • Washer (attaching parts)					8
13	W-103828	• • Bolt (attaching parts)					8
14	79285	• Guard, Prox Switch					2
15	78416	• Switch, Prox					2
16	78417	• Cable, Prox Switch					2
17		• Tie-Down (attaching parts)					2

DASH (-) ITEM NOT ILLUSTRATED

HYDRAULIC DRIVE CYLINDER SUB-ASSEMBLY

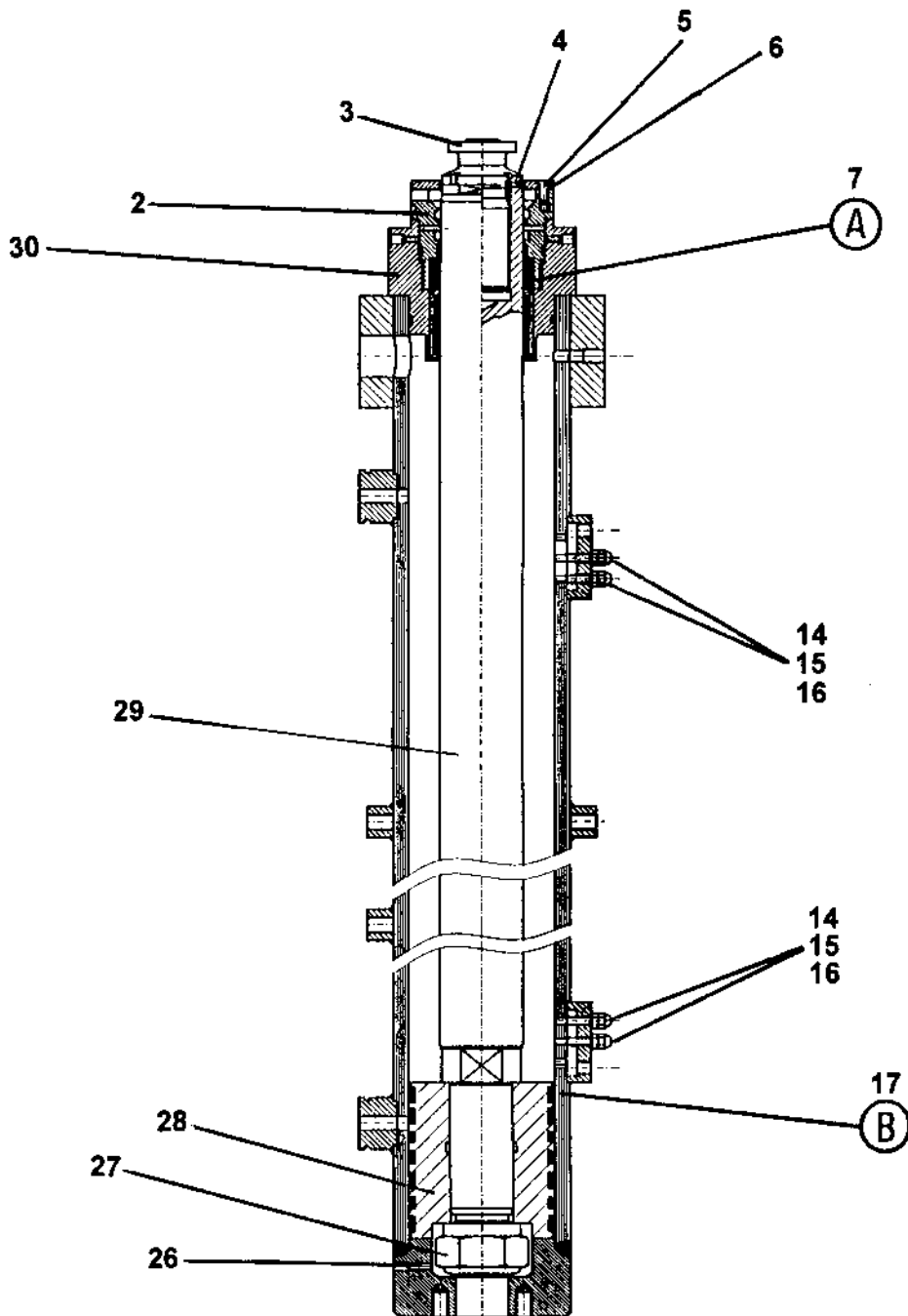

ITEM NO.	REED'S PARTS NO.	DESCRIPTION					QTY
		1	2	3	4	5	
-1	W-154939	Sub-Assembly, Hydraulic Drive Cylinder (See Group 60, Figure 07 for NHA)					Ref
2	W-104890	• Carrier, Sealing					1
3	W-104146	• Joint, Piston					1
4	W-105739	• Screw, Set					1
5	W-103397	• Screw, M8 Sunk					3
6	W-105726	• Deflector					1
7	W-104690	• Set, Rod Sealing					1
8	W-102584	• • V-Packing					1
9	W-105738	• • Support, Rod					1
10	W-105731	• • O-Ring					1
11	W-100259	• • Wiper					1
12	W-105729	• • Wiper					1
13	W-105732	• • Sealing					1
14	W-105740	• Screw, M8 Set					4
15	W-102880	• Nut, hex					4
16	W-104933	• Nut, Cap					4
17	W-105742	• Set, Sealing					1
18	W-105730	• • Support, Rod					3
19	W-105733	• • Ring, Back up					1
20	W-105734	• • O-Ring					1
21	W-101269	• • Ring, Unit					8
22	W-105736	• • Ring, Back Up					2
23	W-105737	• • O-Ring					1
24	W-105049	• • Ring, Piston					4
25	W-105735	• • Ring, Guide					3
26	W-100528	• Screw, Rocking					3
27	W-105728	• Nut, Piston					1
28	W-105727	• Piston					1
29	W-105724	• Rod, Piston					1
30	W-105725	• Piece, Guard					1

DASH (-) ITEM NOT ILLUSTRATED

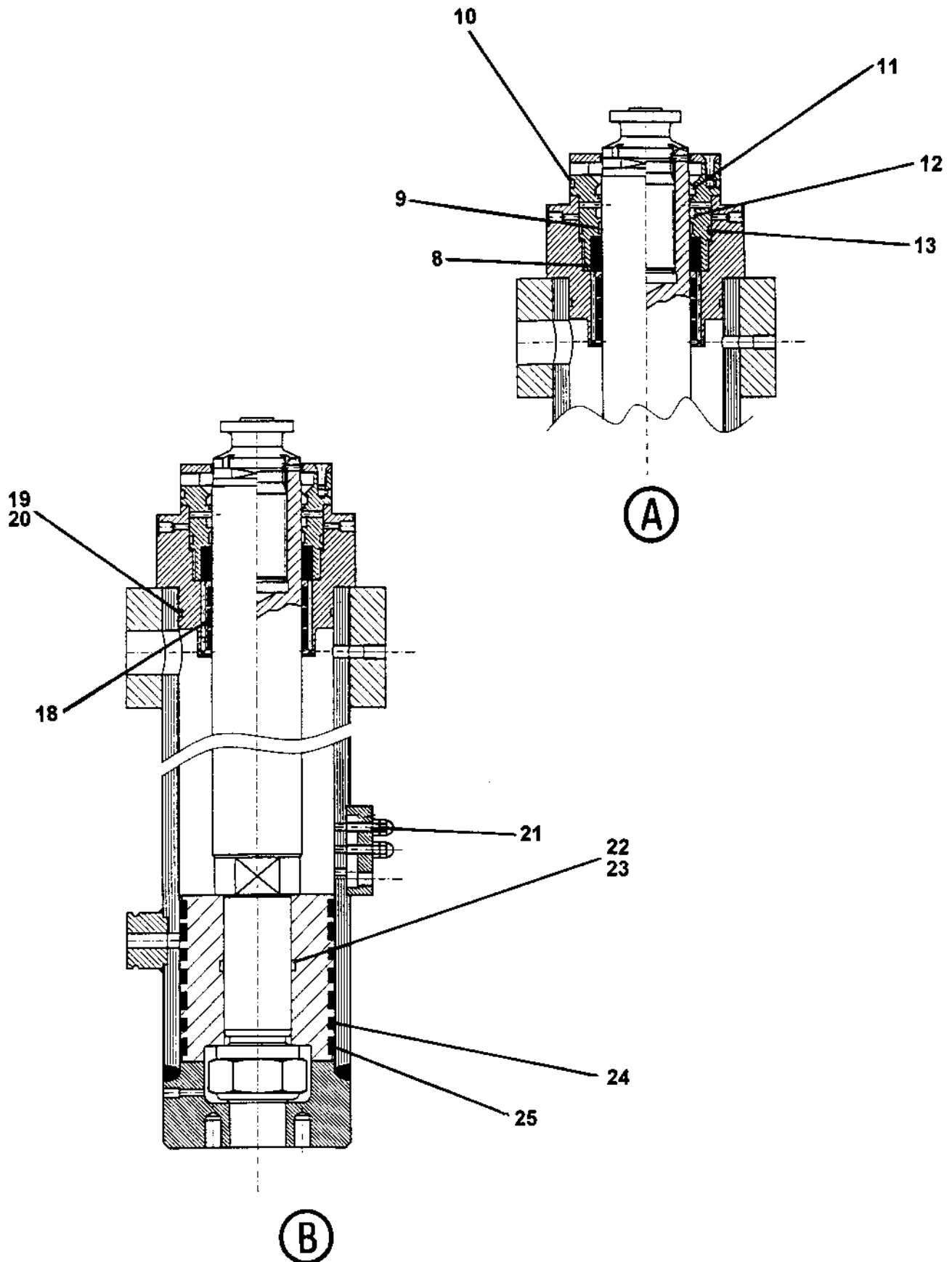

ITEM NO.	REED'S PARTS NO.	DESCRIPTION					QTY
		1	2	3	4	5	
-1	W-154939	Sub-Assembly, Hydraulic Drive Cylinder (See Group 60, Figure 07 for NHA)					Ref
2	W-104890	• Carrier, Sealing					1
3	W-104146	• Joint, Piston					1
4	W-105739	• Screw, Set					1
5	W-103397	• Screw, M8 Sunk					3
6	W-105726	• Deflector					1
7	W-104690	• Set, Rod Sealing					1
8	W-102584	• • V-Packing					1
9	W-105738	• • Support, Rod					1
10	W-105731	• • O-Ring					1
11	W-100259	• • Wiper					1
12	W-105729	• • Wiper					1
13	W-105732	• • Sealing					1
14	W-105740	• Screw, M8 Set					4
15	W-102880	• Nut, hex					4
16	W-104933	• Nut, Cap					4
17	W-105742	• Set, Sealing					1
18	W-105730	• • Support, Rod					3
19	W-105733	• • Ring, Back up					1
20	W-105734	• • O-Ring					1
21	W-101269	• • Ring, Unit					8
22	W-105736	• • Ring, Back Up					2
23	W-105737	• • O-Ring					1
24	W-105049	• • Ring, Piston					4
25	W-105735	• • Ring, Guide					3
26	W-100528	• Screw, Rocking					3
27	W-105728	• Nut, Piston					1
28	W-105727	• Piston					1
29	W-105724	• Rod, Piston					1
30	W-105725	• Piece, Guard					1

DASH (-) ITEM NOT ILLUSTRATED



MODEL *XXT 42* TRUCK MOUNTED
CONCRETE BOOM PUMP
ILLUSTRATED PARTS MANUAL

XXT 42
PARTS
GROUP 60
FIGURE 09
PAGE 01

THIS PAGE INTENTIONALLY LEFT BLANK.

REED TRUCK MOUNTED CONCRETE BOOM PUMP MODEL XXT 42 ILLUSTRATED PARTS MANUAL GROUP 70 FRAME AND SUPPORT INSTALLATION CONTAINS THE FOLLOWING FIGURES:

- FIGURE 00** TABLE OF CONTENTS
- FIGURE 01** FRAME AND SUPPORT INSTALLATION
- FIGURE 02** TURRET ASSEMBLY
- FIGURE 03** MOTOR AND REDUCTION ASSEMBLY
- FIGURE 04** ROTATION UNIT ASSEMBLY
- FIGURE 05** SUPPORT FRAME STABILIZERS ASSEMBLY
- FIGURE 06** FRONT LEFT STABILIZERS TELESCOPIC LEG ASSEMBLY
- FIGURE 07** FRONT RIGHT STABILIZERS TELESCOPIC LEG ASSEMBLY
- FIGURE 08** REAR LEFT SWING OUT LEG ASSEMBLY
- FIGURE 09** REAR RIGHT SWING OUT LEG ASSEMBLY
- FIGURE 10** STABILIZERS VERTICAL JACK CYLINDER ASSEMBLY
- FIGURE 11** SWING OUT CYLINDER ASSEMBLY

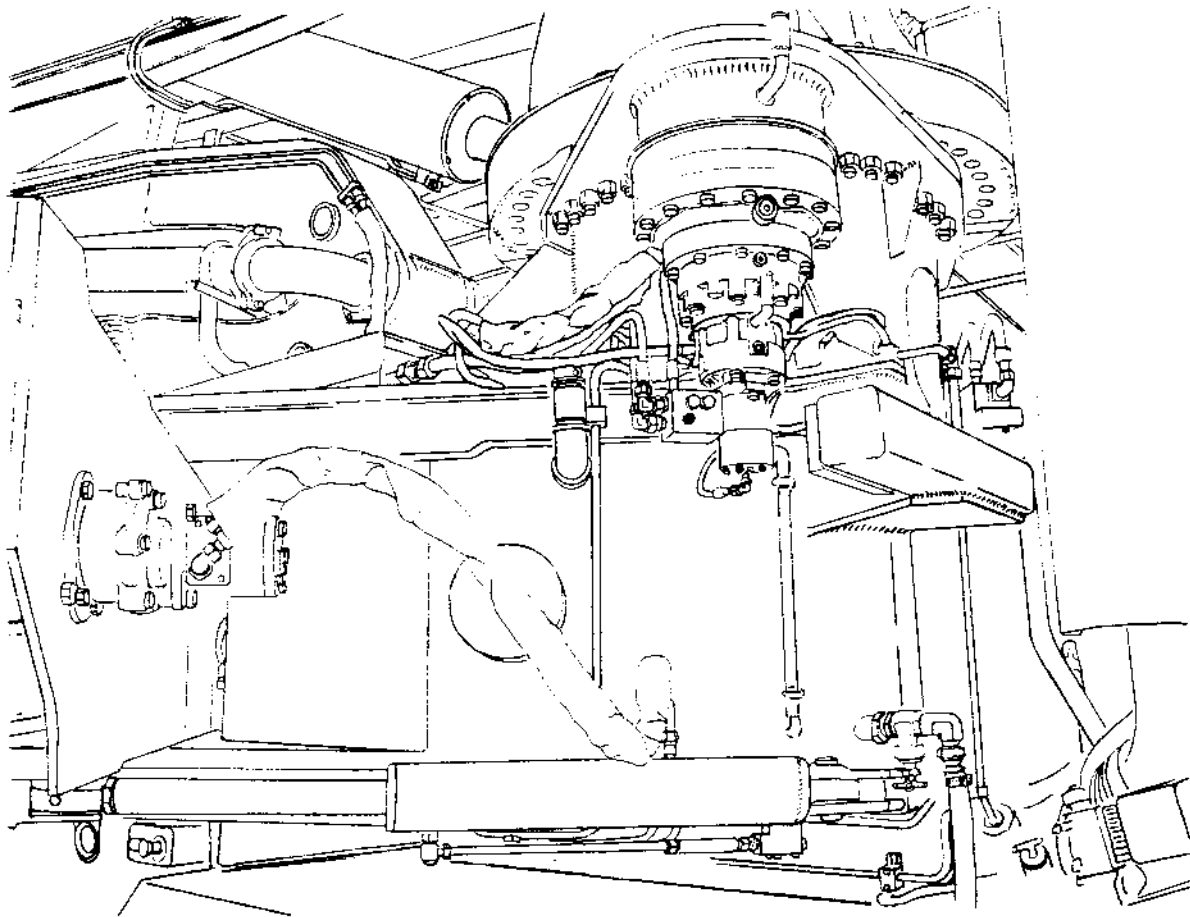

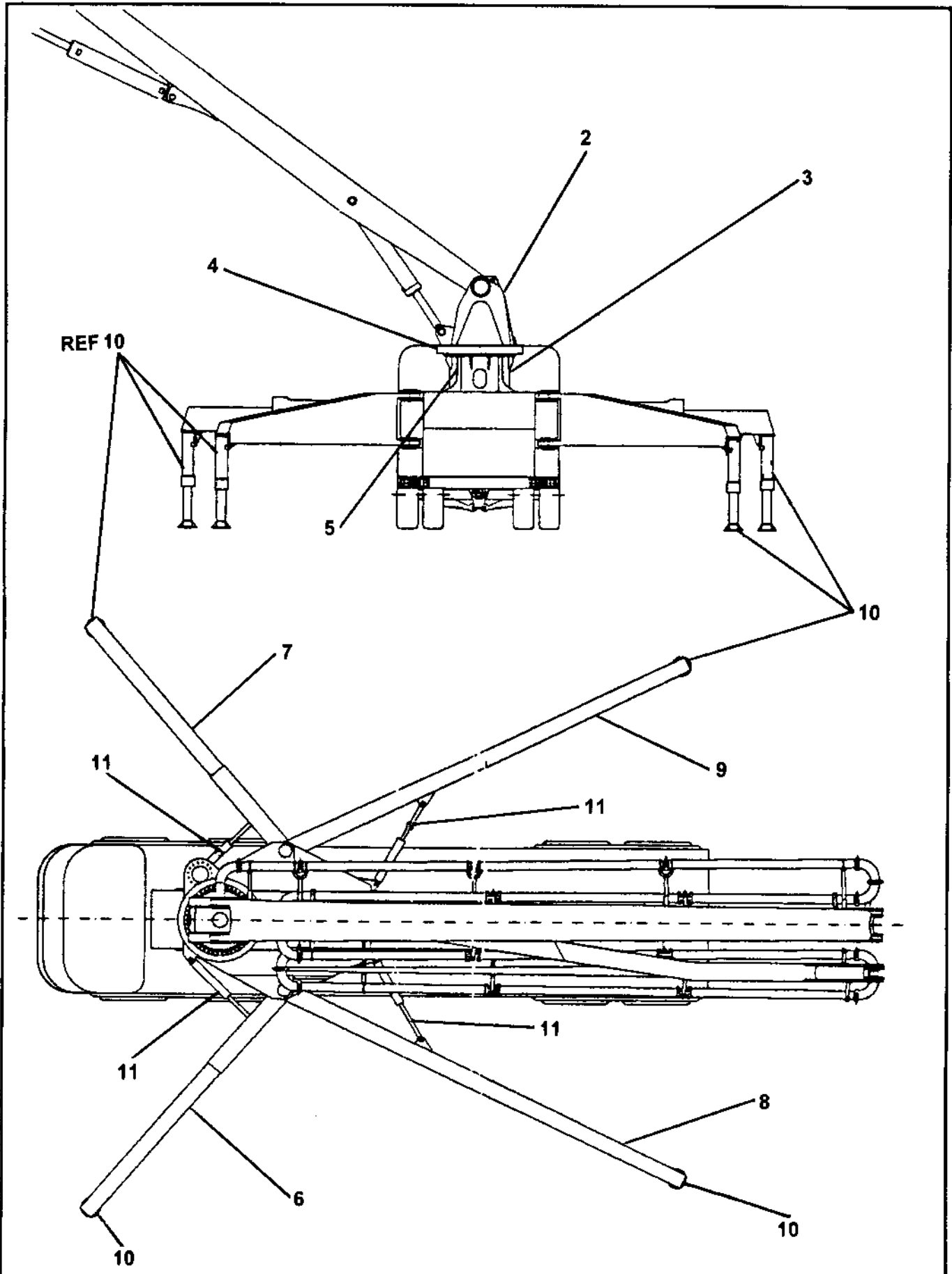

ITEM NO.	REED'S PARTS NO.	DESCRIPTION					QTY
		1	2	3	4	5	
-1	70-01	Installation, Frame And Support (See Group 10, Figure 01 for NHA)					Ref
2	C-2F1	• Assembly, Turret (See Group 70, Figure 02 for DET)					1
3	C-2G1	• Assembly, Motor And Reduction (See Group 70, Figure 03 for DET)					1
4	C-2G2	• Assembly, Rotation Unit (See Group 70, Figure 04 for DET)					1
5	C-2H1	• Assembly, Support Frame Stabilizers (See Group 70, Figure 05 for DET)					1
6	C-2K1-L	• Assembly, Front Left Side Stabilizers Telescopic Leg (See Group 70, Figure 06 for DET)					1
7	C-2K1-R	• Assembly, Front Right Side Stabilizers Telescopic Leg (See Group 70, Figure 07 for DET)					1
8	C-2M1-L	• Assembly, Rear Left Side Swing Out Leg (See Group 70, Figure 08 for DET)					1
9	C-2M1-R	• Assembly, Rear Right Side Swing Out Leg (See Group 70, Figure 09 for DET)					1
10	C-2L5	• Assembly, Stabilizer Vertical Jack Cylinder (See Group 70, Figure 10 for DET)					4
11	C-2M3	• Assembly, Swing Out Cylinder (See Group 70, Figure 11 for DET)					4

DASH (-) ITEM NOT ILLUSTRATED

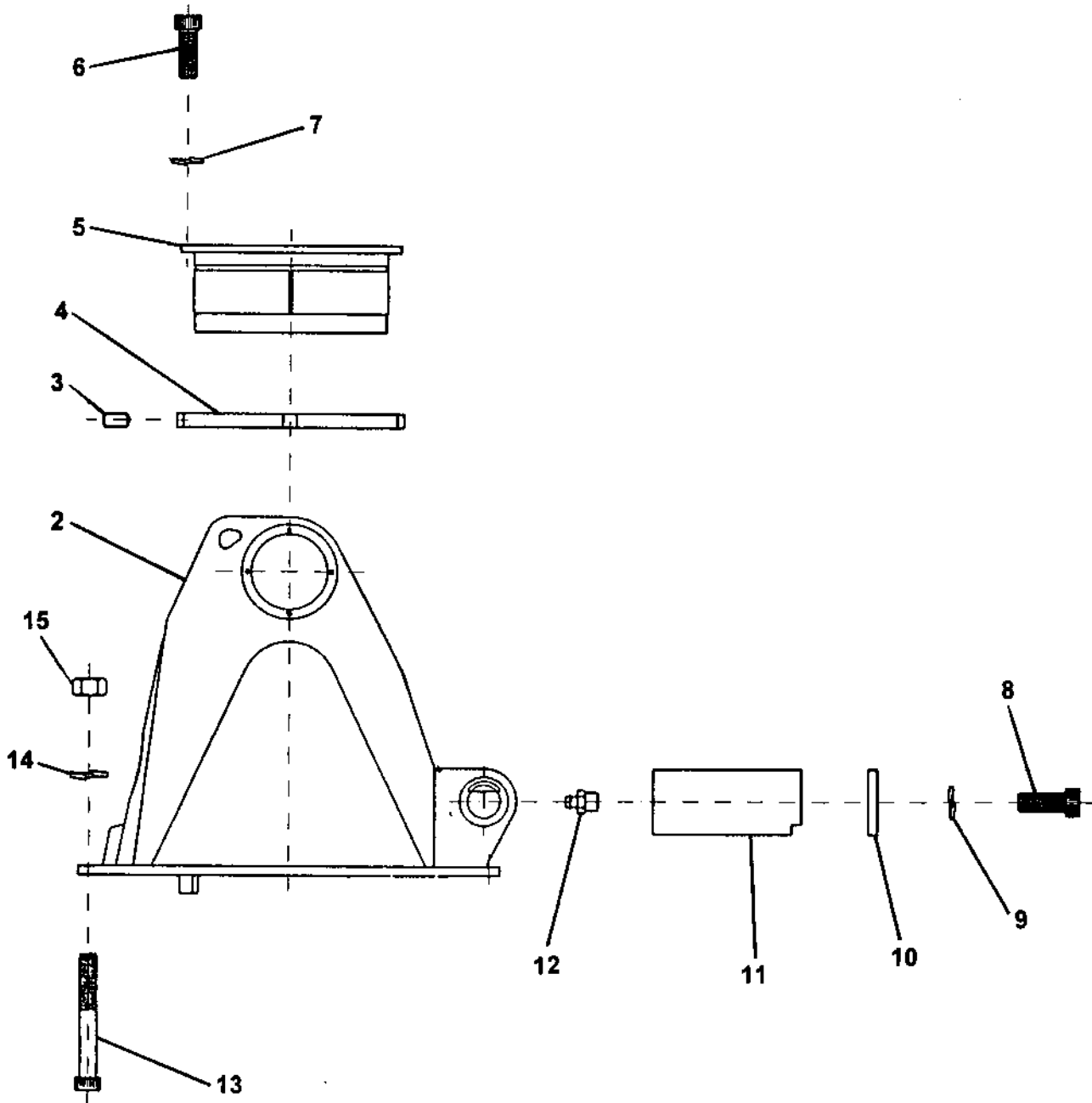
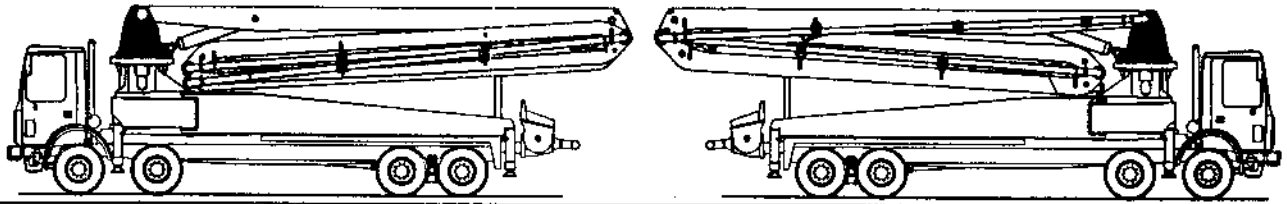

REED**TURRET ASSEMBLY****XXT 42
PARTS
GROUP 70
FIGURE 02
PAGE 02**

ITEM NO.	REED'S PARTS NO.	DESCRIPTION					QTY
		1	2	3	4	5	
-1	C-2F1	Assembly, Turret (See Group 70, Figure 01 for NHA)					Ref
2	C-2F101	• Head, Rotating					1
3	C-VG122.061010	• Screw					4
4	C-GV228.2015	• Ring, Threaded					2
5	C-2P120	• Pin					2
6	C-VC110.142040	• Screw					8
7	C-UE110.14	• Washer, Elastic					8
8	C-VC110.101525	• Screw					1
9	C-UE110.10	• Washer, Elastic					1
10	C-UD080.1108	• Washer, Pin Locking					1
11	C-2P119	• Pin					1
12	C-VI131.1010	• Nipple, Grease					1
13	C-VC130.2730C6	• Screw					48
14	C-UE110.27	• Washer					48
15	C-VD113.2730	• Nut					48

DASH (-) ITEM NOT ILLUSTRATED

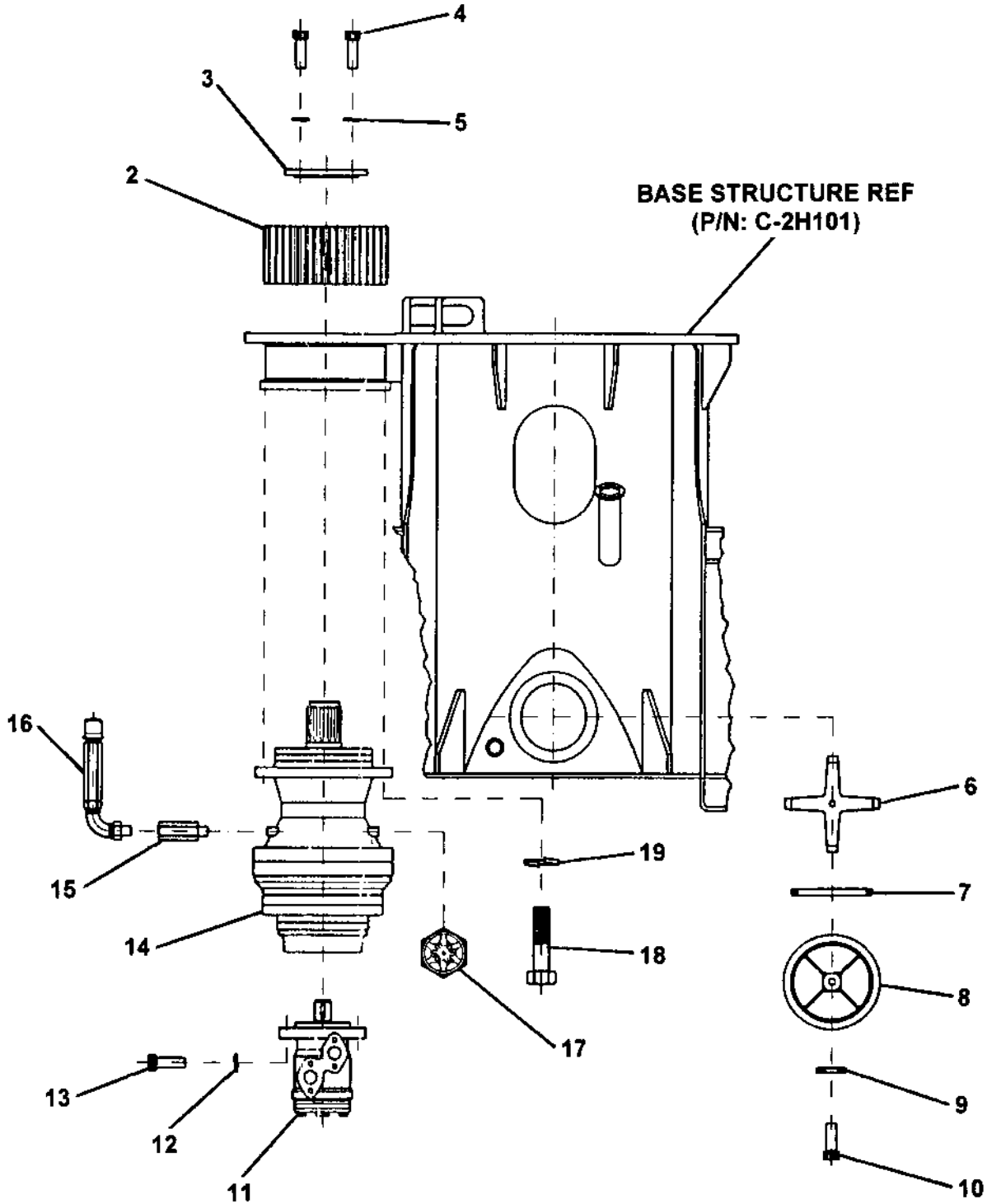
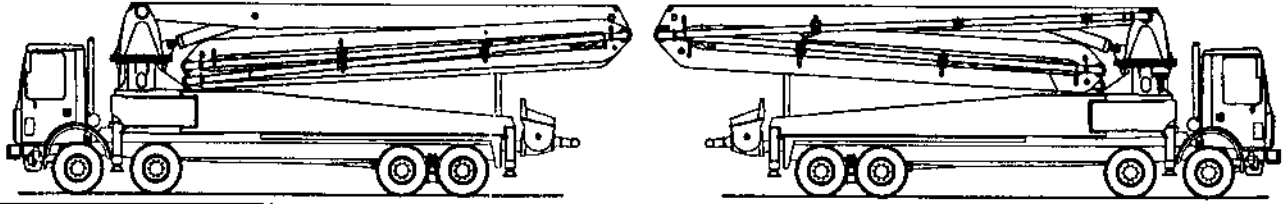

ITEM NO.	REED'S PARTS NO.	DESCRIPTION					QTY
		1	2	3	4	5	
-1	C-2G1	Assembly, Motor And Reduction (See Group 70, Figure 01 for NHA)					Ref
2	C-RP100.21415	• Pinion					1
3	C-RP100.2	• Washer, Pinion					1
4	C-VC110.101530	• Screw					3
5	C-UE110.10	• Washer, Elastic					3
6	C-DT301	• Support, Cover					1
7	C-AO120.371	• Gasket, Seal					1
8	C-DT300	• Cover					1
9	C-AB110.016	• Ring-Bonded					1
10	C-VC110.162040	• Screw					1
11	C-MI200.160	• Assembly, Hydraulic Motor					1
12	C-UE110.12	• Washer, Elastic					2
13	C-VC110.1275	• Screw					2
14	C-RE100.23250	• Unit, Reduction					1
15	C-NP020.040MF	• Fitting					1
16	C-FS020	• Filter, Air Hole					1
17	C-LL301	• Level, Oil					1
18	C-VC110.1620C5	• Screw					15
19	C-UE110.16	• Washer, Elastic					15

DASH (-) ITEM NOT ILLUSTRATED



ROTATION UNIT ASSEMBLY

XXT 42
PARTS
GROUP 70
FIGURE 04
PAGE 01

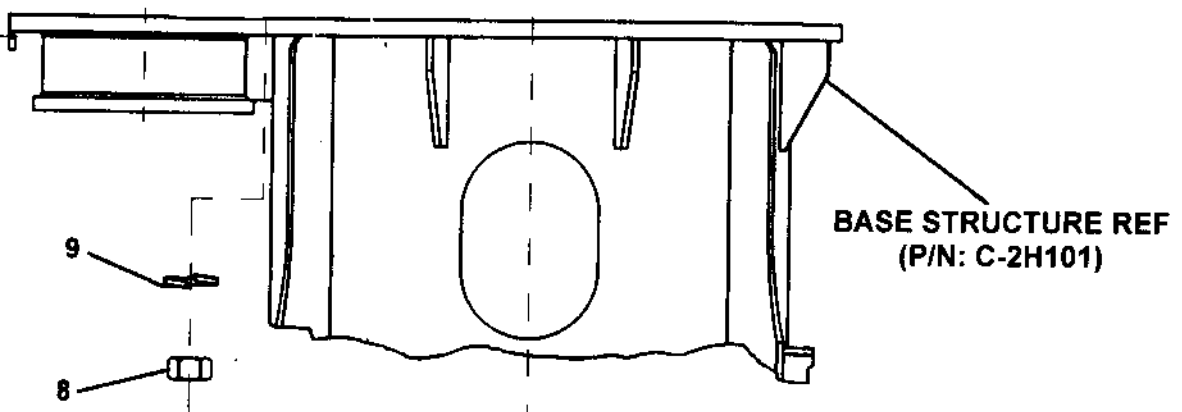
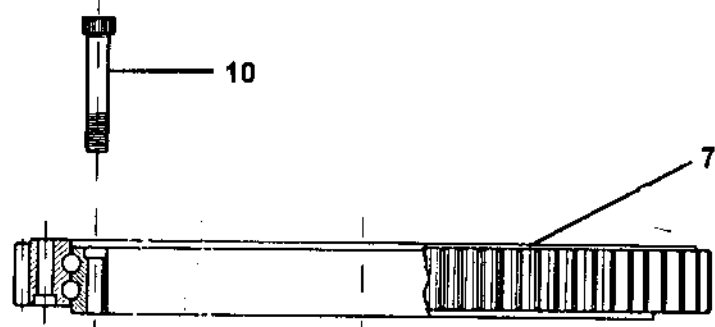
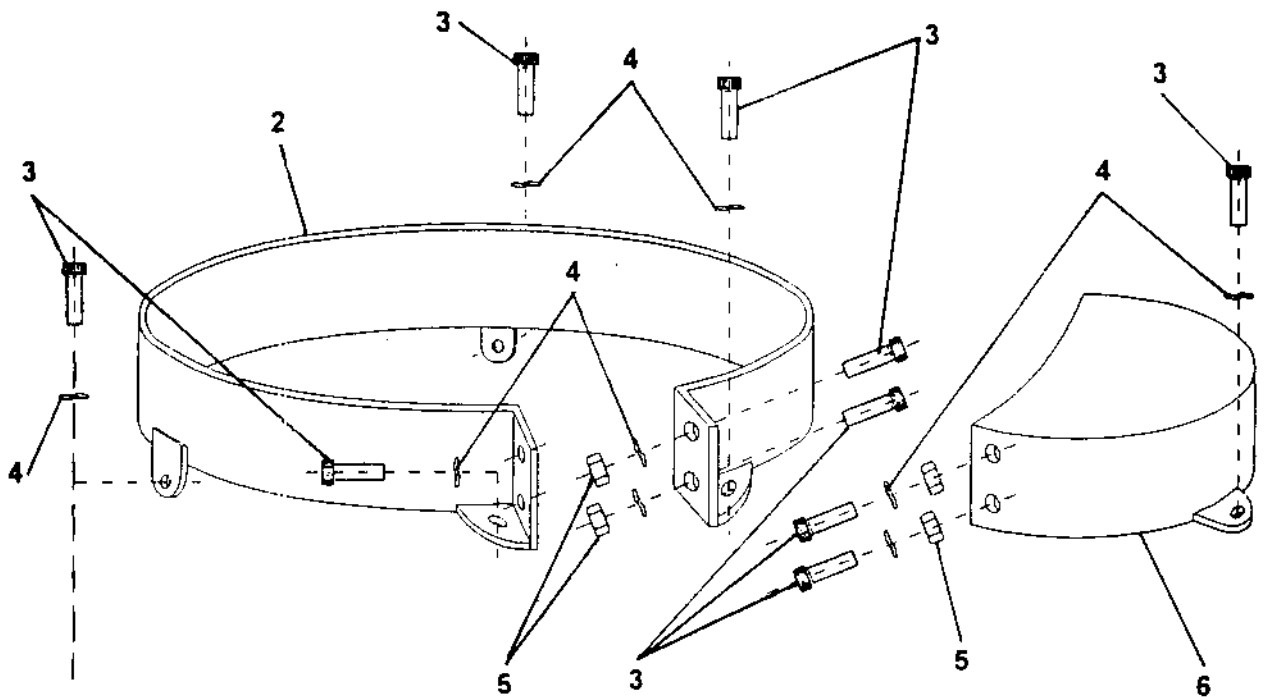
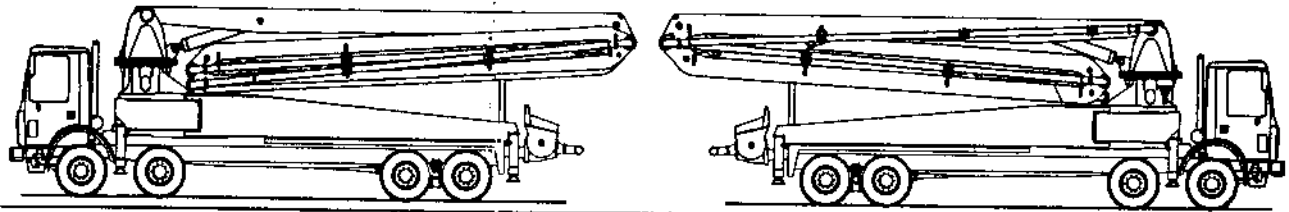

REVISION:

ITEM NO.	REED'S PARTS NO.	DESCRIPTION					QTY
		1	2	3	4	5	
-1	C-2G2	Assembly, Rotation Unit (See Group 70, Figure 01 for NHA)					Ref
2	C-2G202	• Protection, Rotating					1
3	C-VC110.081225	• Screw					9
4	C-UE110.08	• Washer, Elastic (attaching parts)					9
5	C-VD111.0812	• Nut					4
6	C-2G203	• Protection, Pinion					1
7	C-CB112.1344	• Bearing, Rotation					1
8	C-VD113.2730	• Nut (attaching parts)					48
9	C-UE110.27	• Washer (attaching parts)					48
10	C-VC130.2730C6	• Screw (attaching parts)					48

DASH (-) ITEM NOT ILLUSTRATED

SUPPORT FRAME STABILIZERS ASSEMBLY

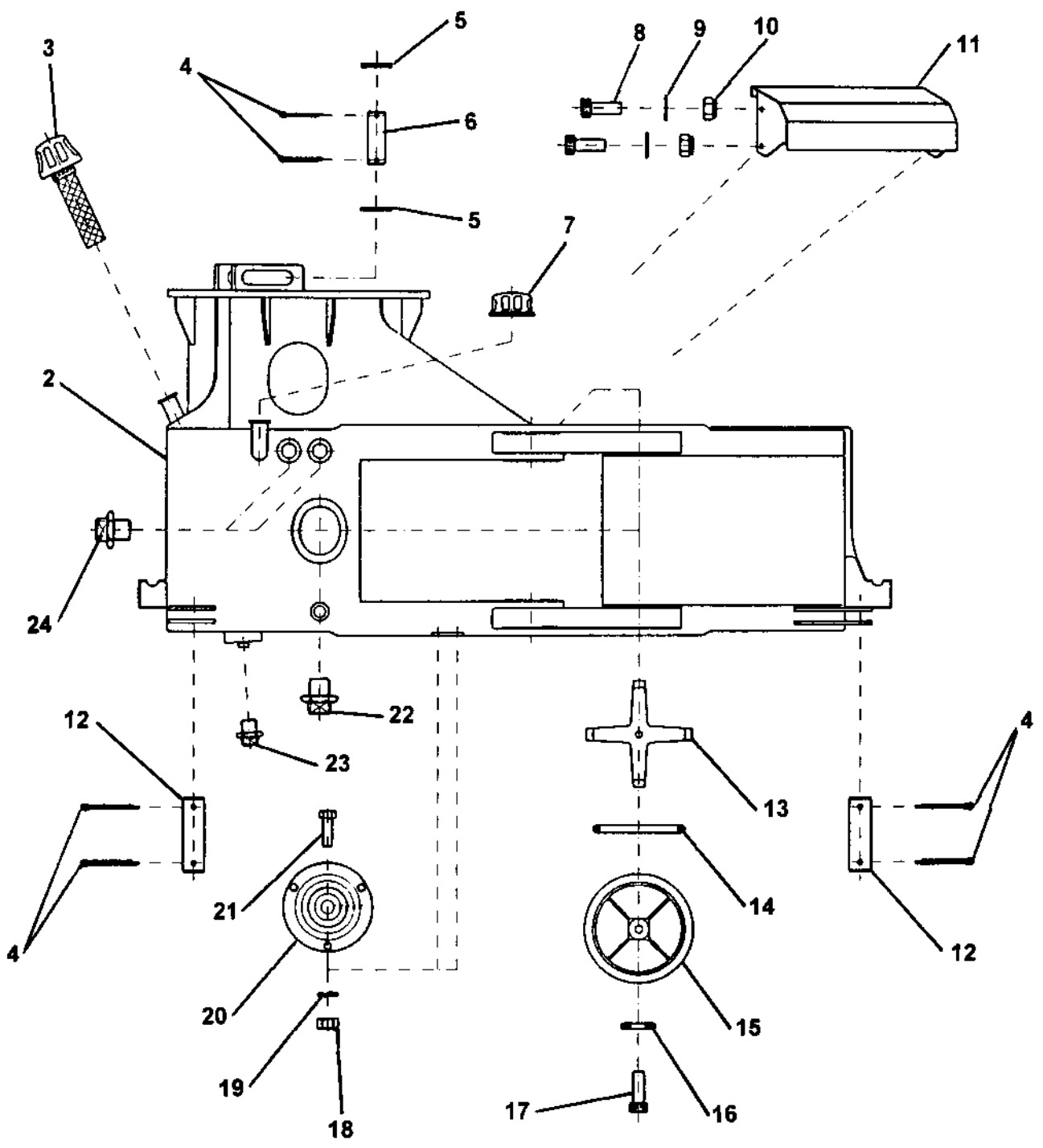
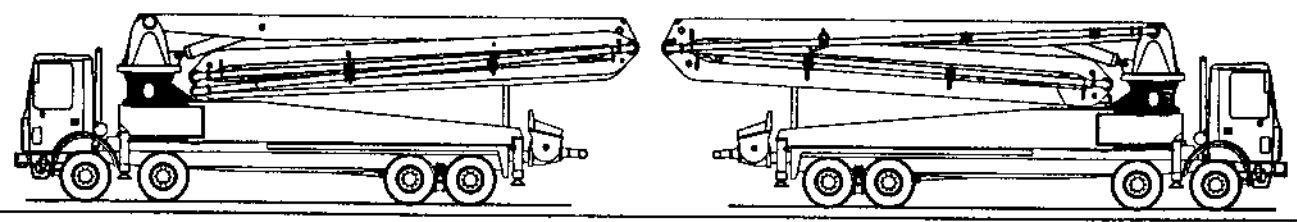

ITEM NO.	REED'S PARTS NO.	DESCRIPTION					QTY
		1	2	3	4	5	
-1	C-2H1	Assembly, Support Frame Stabilizers (See Group 70, Figure 01 for NHA)					Ref
2	C-2H101	• Structure, Base					1
3	C-DT200	• Plug, Screw for Hydraulic Oil Tank					1
4	C-VS110.08070	• Pin, Split					6
5	C-2G205	• Washer					2
6	C-2P202	• Pin					1
7	C-DT121	• Plug, Screw for Water Tank					1
8	C-VC110.081225	• Screw					4
9	C-UP110.08	• Washer					4
10	C-VD221.0812	• Nut, Self Locking					4
11	C-1H106	• Cover, Distributor					1
12	C-2P207	• Pin					2
13	C-DT301	• Support, Cover					2
14	C-A0120.371	• Gasket, Seal					2
15	C-DT300	• Cover					2
16	C-AB110.016	• Ring-Bonded					2
17	C-VC110.162040	• Screw					2
18	C-VD111.0407	• Nut					3
19	C-UE110.04	• Washer, Elastic					3
20	C-LL401	• Level					1
21	C-VE110.040715	• Screw					3
22	C-DT109	• Plug, Screw					2
23	C-DT105	• Plug, Screw					3
24	C-DT106	• Plug, Screw					1

DASH (-) ITEM NOT ILLUSTRATED

REED

FRONT STABILIZERS LEFT SIDE TELESCOPIC LEG ASSEMBLY

XXT 42
PARTS
GROUP 70
FIGURE 06
PAGE 01

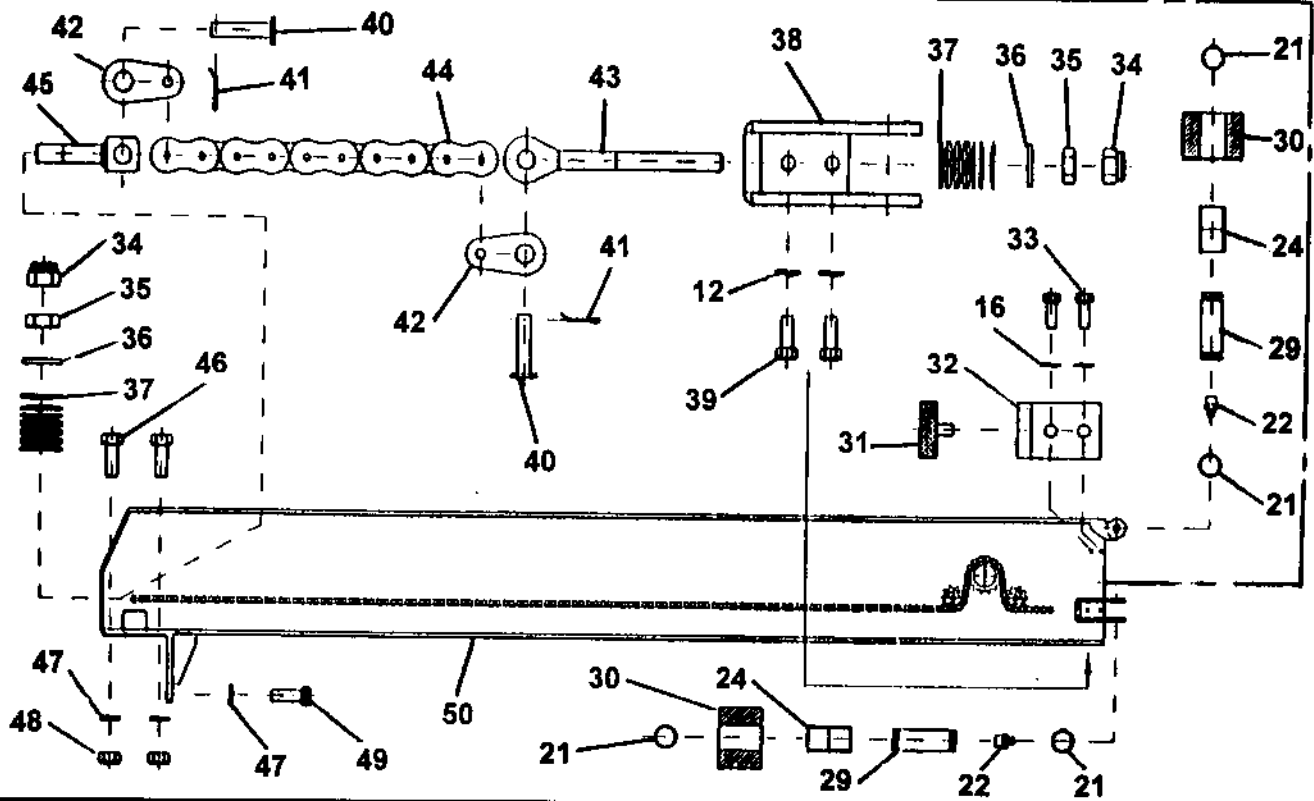
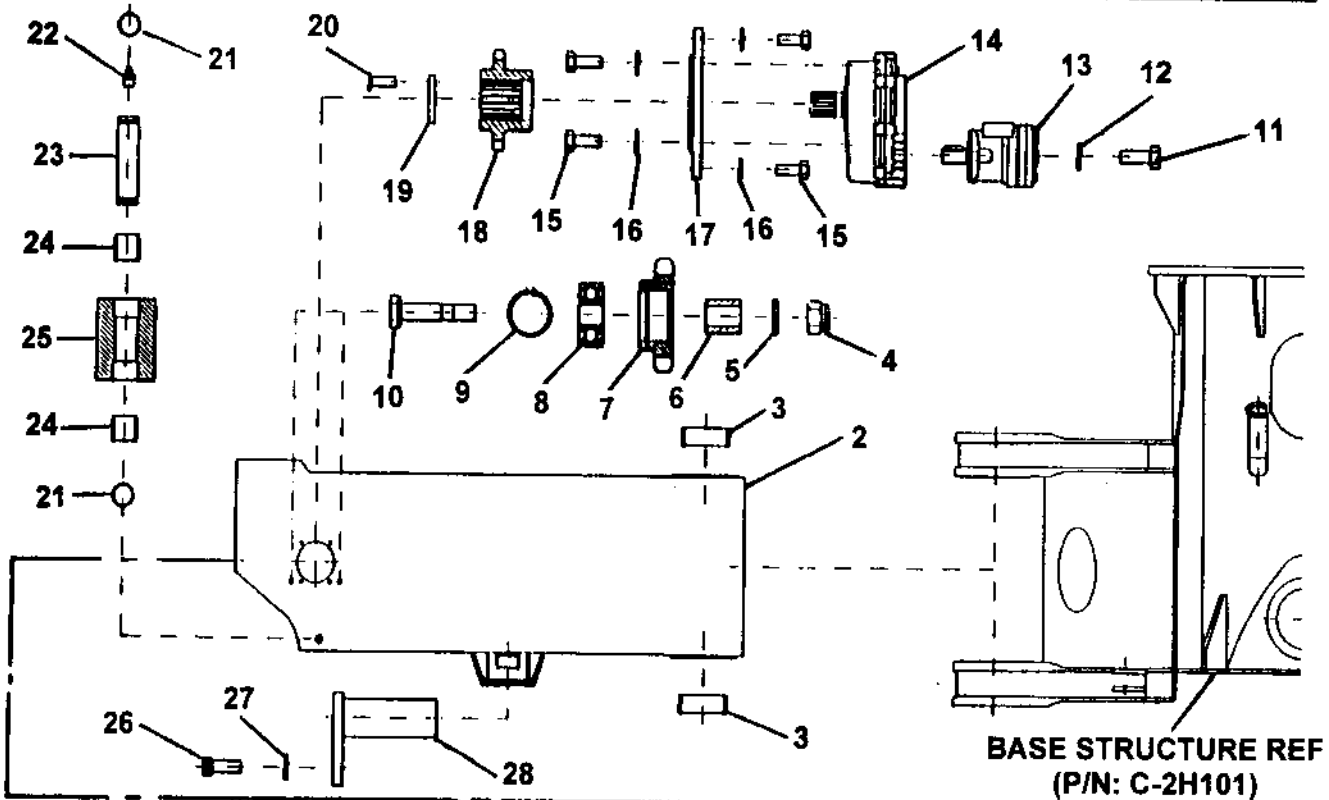
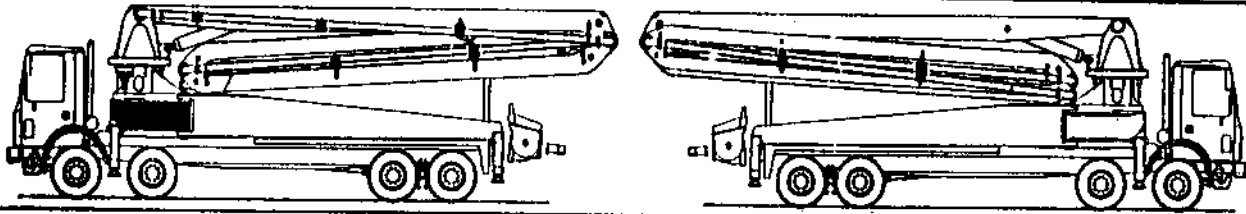

REED**FRONT STABILIZERS LEFT SIDE
TELESCOPIC LEG ASSEMBLY****XXT 42
PARTS
GROUP 70
FIGURE 06
PAGE 02**

ITEM NO.	REED'S PARTS NO.	DESCRIPTION					QTY
		1	2	3	4	5	
-1	C-2K1-L	Assembly, Front Stabilizers Left Side Telescopic Leg (See Group 70, Figure 01 for NHA)					Ref
2	C-2K102	• Weldment, Front Left Side Stabilizers					1
3	C-CD00.205080	• Bearing, Anti-friction					2
4	C-VD221.1420	• Nut, Self Locking					2
5	C-UP110.14	• Washer					2
6	C-9K111A	• Piece, Distance					2
7	C-9K115	• Pinion, Free					2
8	C-CC63002.2RS	• Bearing, Ball					2
9	C-AA120.032	• Ring, Clamping					2
10	C-9K110A	• Pin					2
11	C-VE110.121725	• Screw					2
12	C-UE110.12	• Washer, Elastic					4
13	C-MI300.250	• Assembly, Hydraulic Motor					1
14	C-RE003.00075	• Reducer					1
15	C-VE110.101535	• Screw					4
16	C-UE110.10	• Washer, Elastic					10
17	C-9K113	• Flange, Reducer					1
18	C-9K116	• Pinion					1
19	C-9K112	• Washer					1
20	C-VT110.061025	• Screw					3
21	C-AA110.025	• Ring, Clamping					6
22	C-VI131.0608	• Nipple, Grease					3
23	C-3P206	• Pin					1
24	C-CD025.02825	• Bearing, Anti-friction					6
25	C-5H105	• Roller					1
26	C-VE110.081220	• Screw					1
27	C-UE110.08	• Washer, Elastic					1
28	C-9P206	• Pin					1

DASH (-) ITEM NOT ILLUSTRATED



FRONT STABILIZERS LEFT SIDE TELESCOPIC LEG ASSEMBLY

XXT 42
PARTS
GROUP 70
FIGURE 06
PAGE 03

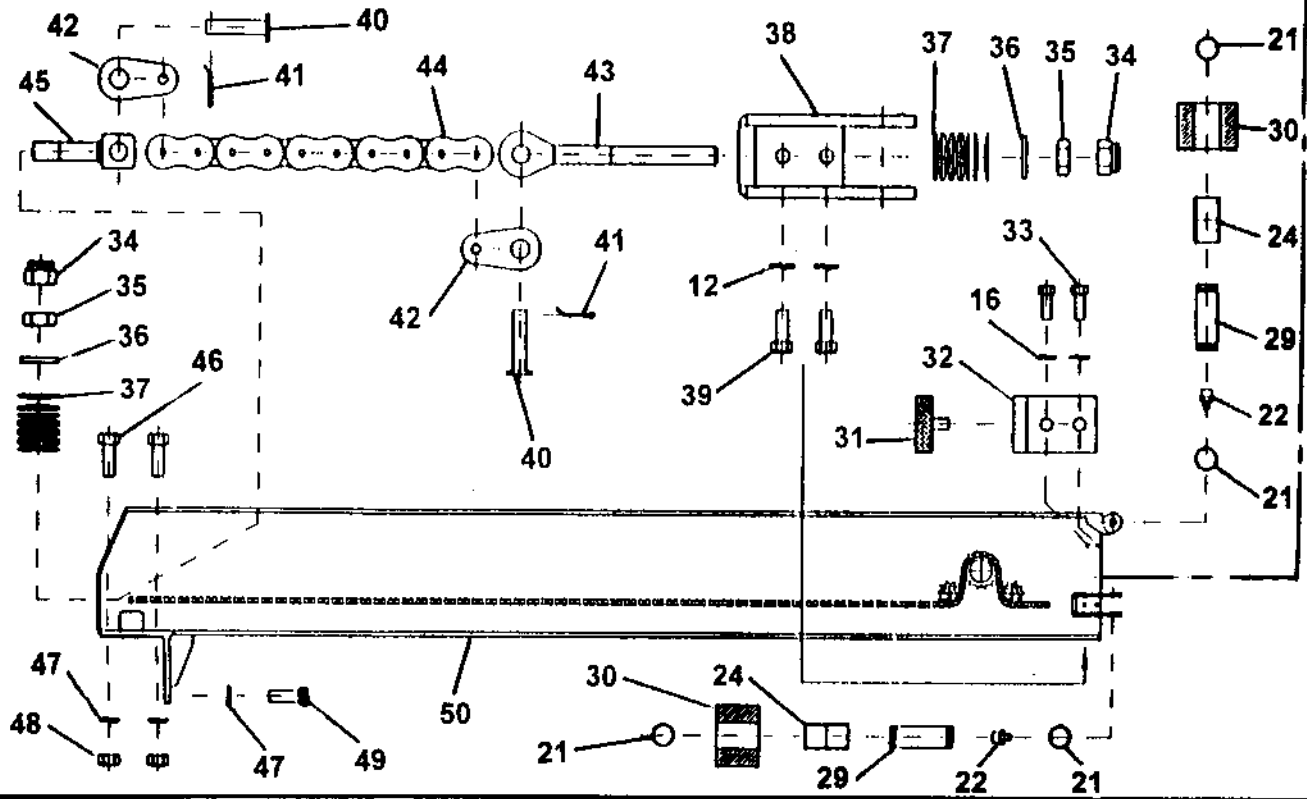
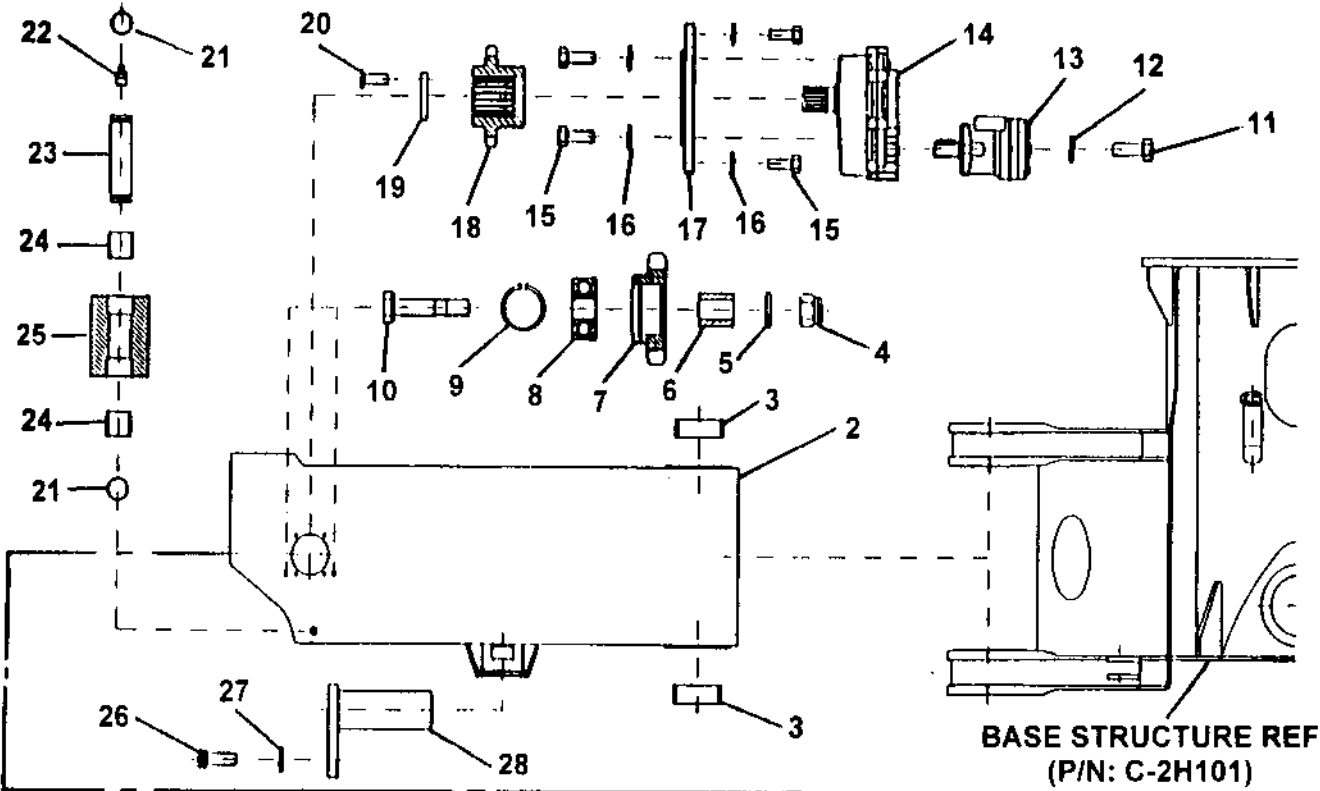
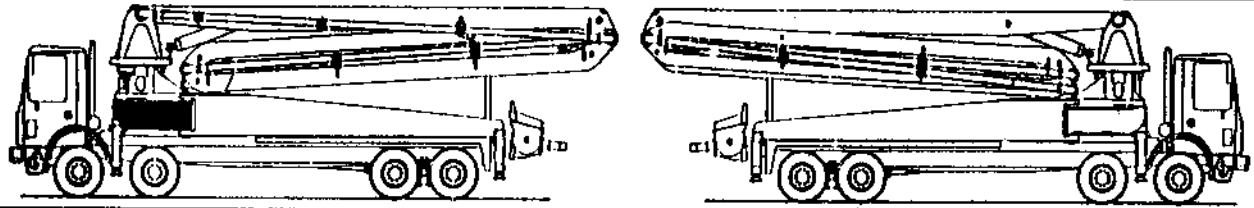

REED**FRONT STABILIZERS LEFT SIDE
TELESCOPIC LEG ASSEMBLY****XXT 42
PARTS
GROUP 70
FIGURE 06
PAGE 04**

ITEM NO.	REED'S PARTS NO.	DESCRIPTION					QTY
		1	2	3	4	5	
12	C-UE110.12	• Washer, Elastic					4
13	C-MI300.250	• Assembly, Hydraulic Motor					1
14	C-RE003.00075	• Reducer					1
15	C-VE110.101535	• Screw					4
16	C-UE110.10	• Washer, Elastic					10
17	C-9K113	• Flange, Reducer					1
18	C-9K116	• Pinion					1
19	C-9K112	• Washer					1
20	C-VT110.061025	• Screw					3
21	C-AA110.025	• Ring, Clamping					6
22	C-VI131.0608	• Nipple, Grease					3
23	C-3P206	• Pin					1
24	C-CD025.02825	• Bearing, Anti-friction					6
25	C-5H105	• Roller					1
26	C-VE110.081220	• Screw					1
27	C-UE110.08	• Washer, Elastic					1
28	C-9P206	• Pin					1
29	C-4P201	• Pin					2
30	C-4H102	• Roller					2
31	C-UG220.05010	• Pad, Rubber					1
32	C-9K114	• Support					1
33	C-VE110.101525	• Screw					2
34	C-VD221.1620	• Nut, Self Locking					2
35	C-VD112.1620	• Nut					2
36	C-UP110.06	• Washer					2
37	C-LT016	• Spring, Bauer					20
38	C-2K103	• Supporter, Roller and Chain					1
39	C-VE110.121730	• Screw					2
40	C-AC616	• Pin, Chain					2
41	C-VS110.04030	• Pin, Split					2
42	C-9K119	• Connection, Chain					2
43	C-9K107A	• Rod, Chain Tie					1
44	C-AC516.80	• Block, Chain					1
45	C-9K118	• Rod, Chain Tie					1
46	C-VE110.222580	• Screw					4
47	C-UE110.22	• Washer, Elastic					6
48	C-VD111.2225	• Nut					4
49	C-2K202	• Weldment, Front Left Side Telescopic Leg					1

DASH (-) ITEM NOT ILLUSTRATED

REVISION:

REED

FRONT STABILIZERS RIGHT SIDE TELESCOPIC LEG ASSEMBLY

XXT 42
PARTS
GROUP 70
FIGURE 07
PAGE 01

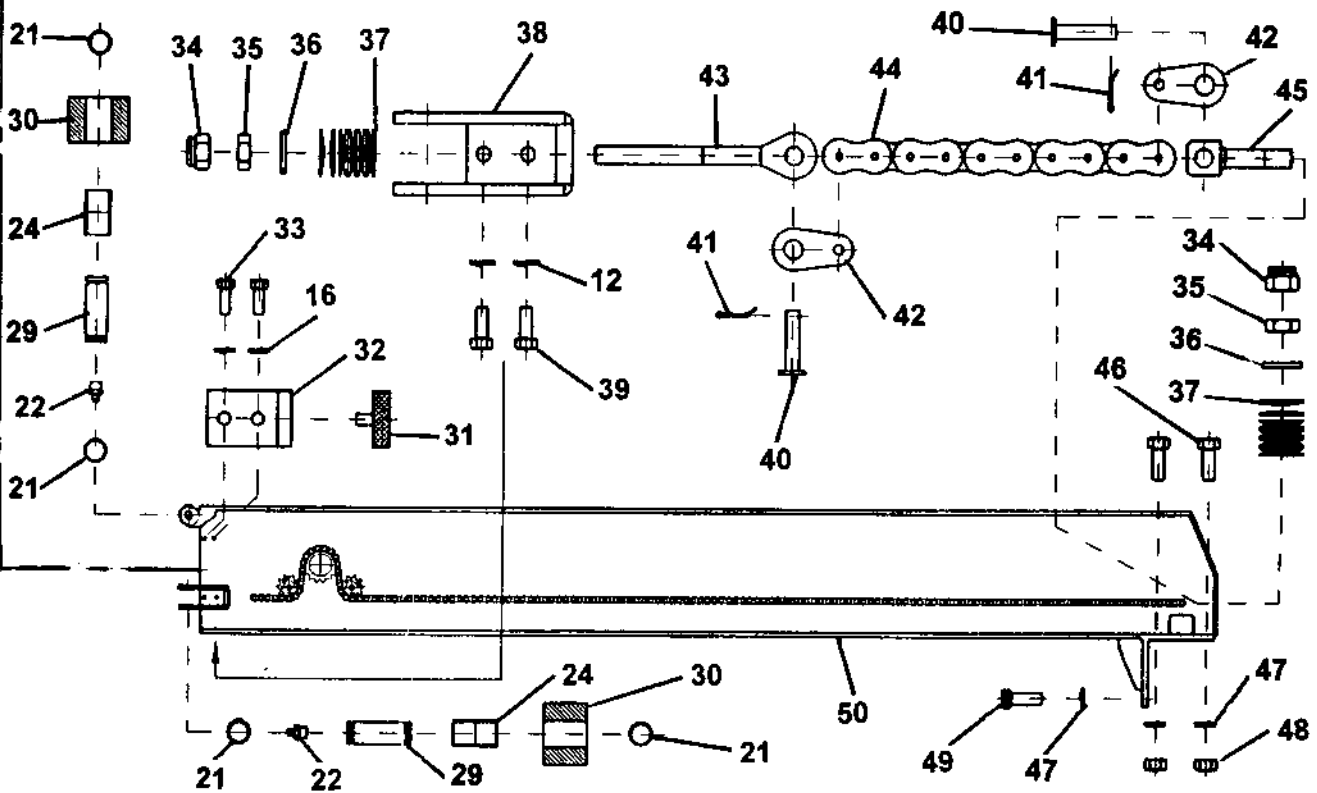
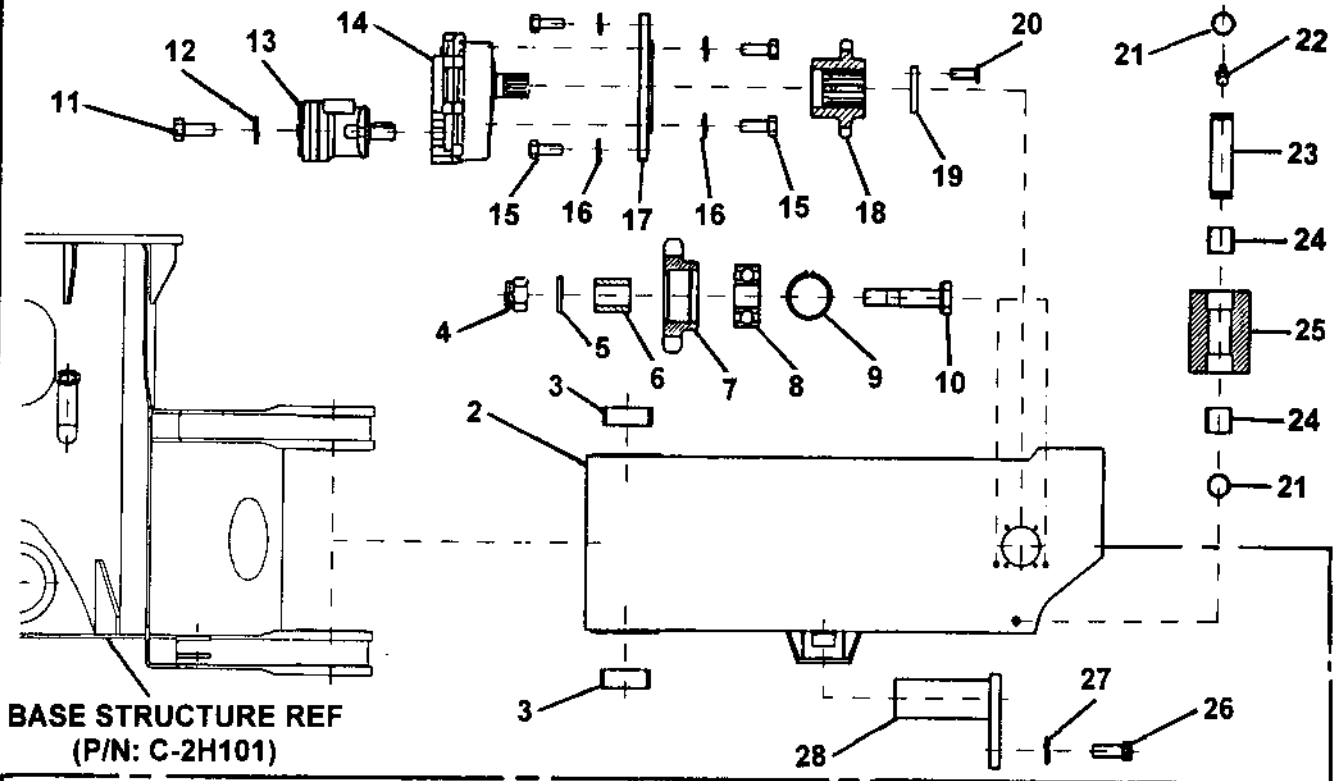
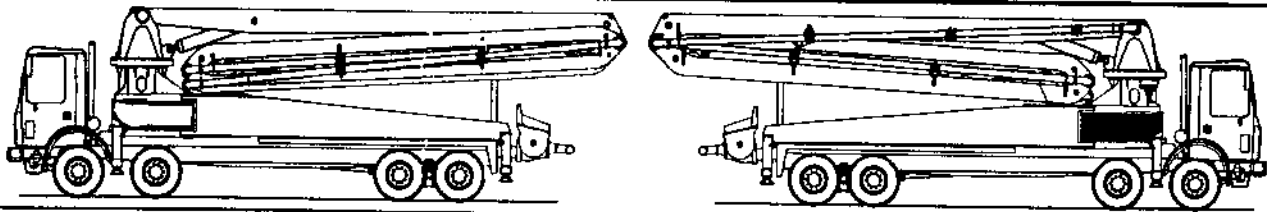

REVISION:

REED**FRONT STABILIZERS RIGHT SIDE
TELESCOPIC LEG ASSEMBLY****XXT 42****PARTS**

GROUP 70

FIGURE 07

PAGE 02

ITEM NO.	REED'S PARTS NO.	DESCRIPTION					QTY
		1	2	3	4	5	
-1	C-2K1-R	Assembly, Front Stabilizers Right Side Telescopic Leg (See Group 70, Figure 01 for NHA)					Ref
2	C-2K101	• Weldment, Front Right Side Stabilizers					1
3	C-CD200.205080	• Bearing, Anti-friction					2
4	C-VD221.1420	• Nut, Self Locking					2
5	C-UP110.14	• Washer					2
6	C-9K111A	• Piece, Distance					2
7	C-9K115	• Pinion, Free					2
8	C-CC63002.2RS	• Bearing, Ball					2
9	C-AA120.032	• Ring, Clamping					2
10	C-9K110A	• Pin					2
11	C-VE110.121725	• Screw					2
12	C-UE110.12	• Washer, Elastic					4
13	C-MI300.250	• Assembly, Hydraulic Motor					1
14	C-RE003.00075	• Reducer					1
15	C-VE110.101535	• Screw					4
16	C-UE110.10	• Washer, Elastic					10
17	C-9K113	• Flange, Reducer					1
18	C-9K116	• Pinion					1
19	C-9K112	• Washer					1
20	C-VT110.061025	• Screw					3
21	C-AA110.025	• Ring, Clamping					6
22	C-VI131.0608	• Nipple, Grease					3
23	C-3P206	• Pin					1
24	C-CD025.02825	• Bearing, Anti-friction					6
25	C-5H105	• Roller					1
26	C-VE110.081220	• Screw					1
27	C-UE110.08	• Washer, Elastic					1
28	C-9P206	• Pin					1

DASH (-) ITEM NOT ILLUSTRATED

FRONT STABILIZERS RIGHT SIDE TELESCOPIC LEG ASSEMBLY

XXT 42
PARTS
GROUP 70
FIGURE 07
PAGE 03

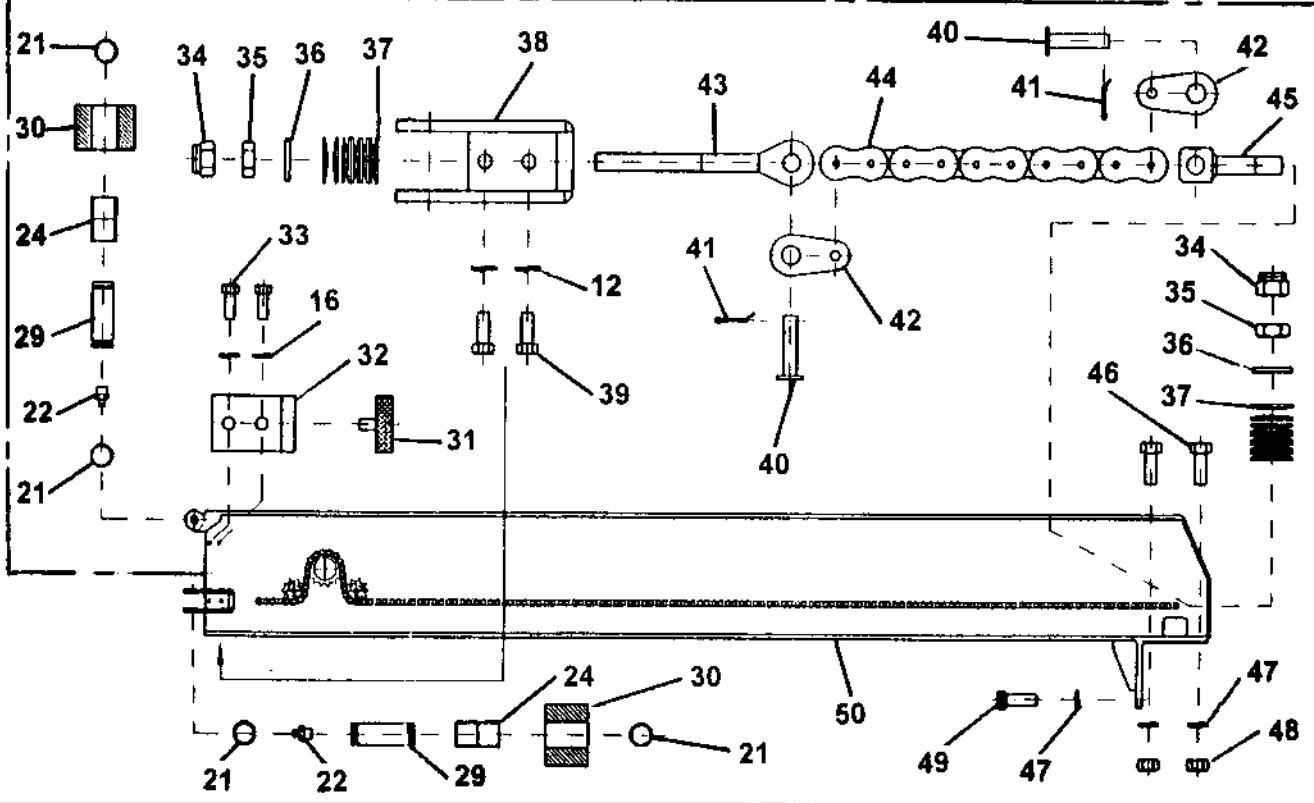
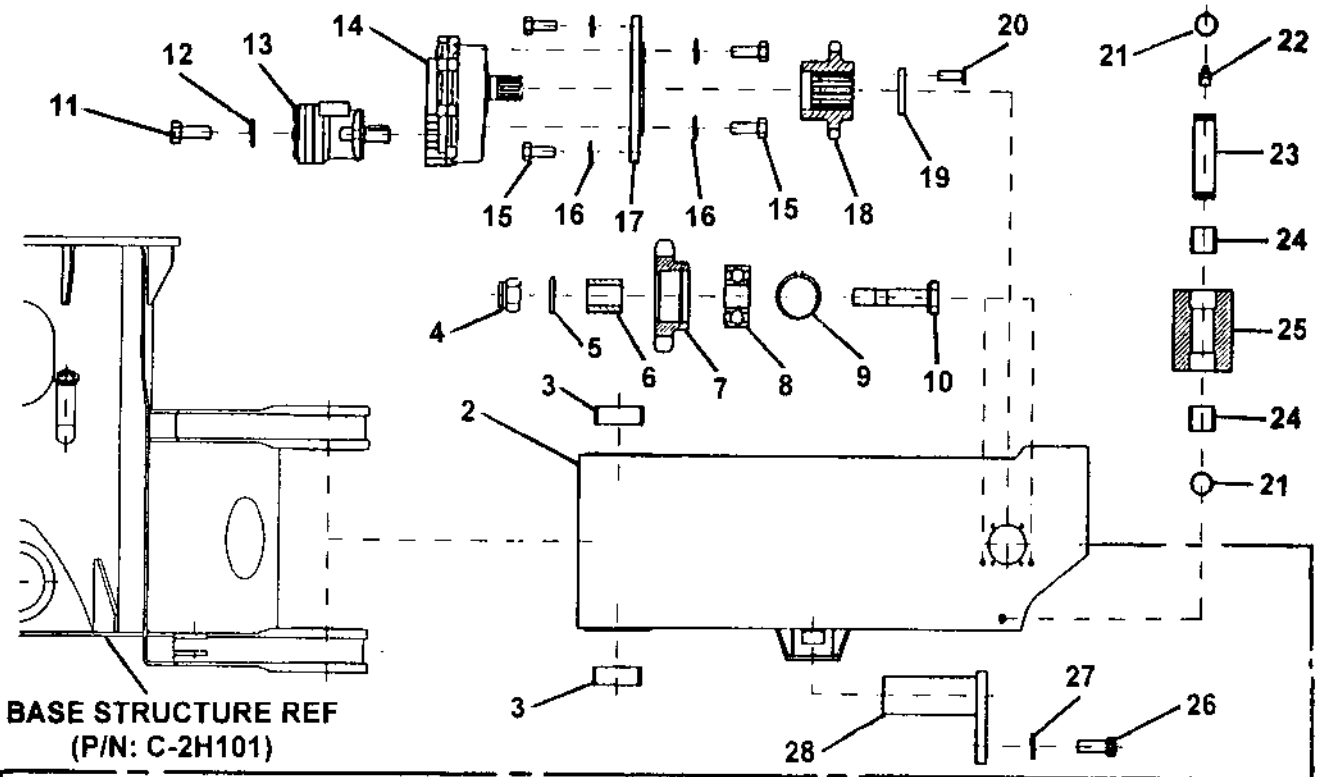
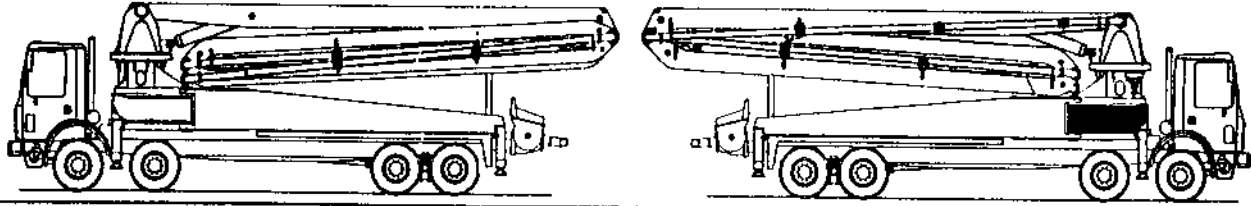

REED**FRONT STABILIZERS RIGHT SIDE
TELESCOPIC LEG ASSEMBLY****XXT 42
PARTS
GROUP 70
FIGURE 07
PAGE 04**

ITEM NO.	REED'S PARTS NO.	DESCRIPTION					QTY
		1	2	3	4	5	
12	C-UE110.12	• Washer, Elastic					4
13	C-MI300.250	• Assembly, Hydraulic Motor					1
14	C-RE003.00075	• Reducer					1
15	C-VE110.101535	• Screw					4
16	C-UE110.10	• Washer, Elastic					10
17	C-9K113	• Flange, Reducer					1
18	C-9K116	• Pinion					1
19	C-9K112	• Washer					1
20	C-VT110.061025	• Screw					3
21	C-AA110.025	• Ring, Clamping					6
22	C-VI131.0608	• Nipple, Grease					3
23	C-3P206	• Pin					1
24	C-CD025.02825	• Bearing, Anti-friction					6
25	C-5H105	• Roller					1
26	C-VE110.081220	• Screw					1
27	C-UE110.08	• Washer, Elastic					1
28	C-9P206	• Pin					1
29	C-4P201	• Pin					2
30	C-4H102	• Roller					2
31	C-UG220.05010	• Pad, Rubber					1
32	C-9K114	• Support					1
33	C-VE110.101525	• Screw					2
34	C-VD221.1620	• Nut, Self Locking					2
35	C-VD112.1620	• Nut					2
36	C-UP110.06	• Washer					2
37	C-LT016	• Spring, Bauer					20
38	C-2K103	• Supporter, Roller and Chain					1
39	C-VE110.121730	• Screw					2
40	C-AC616	• Pin, Chain					2
41	C-VS110.04030	• Pin, Split					2
42	C-9K119	• Connection, Chain					2
43	C-9K107A	• Rod, Chain Tie					1
44	C-AC516.80	• Block, Chain					1
45	C-9K118	• Rod, Chain Tie					1
46	C-VE110.222580	• Screw					4
47	C-UE110.22	• Washer, Elastic					6
48	C-VD111.2225	• Nut					4
49	C-9K201	• Weldment, Front Right Side Telescopic Leg					1

DASH (-) ITEM NOT ILLUSTRATED

REAR LEFT SIDE SWING OUT LEG ASSEMBLY

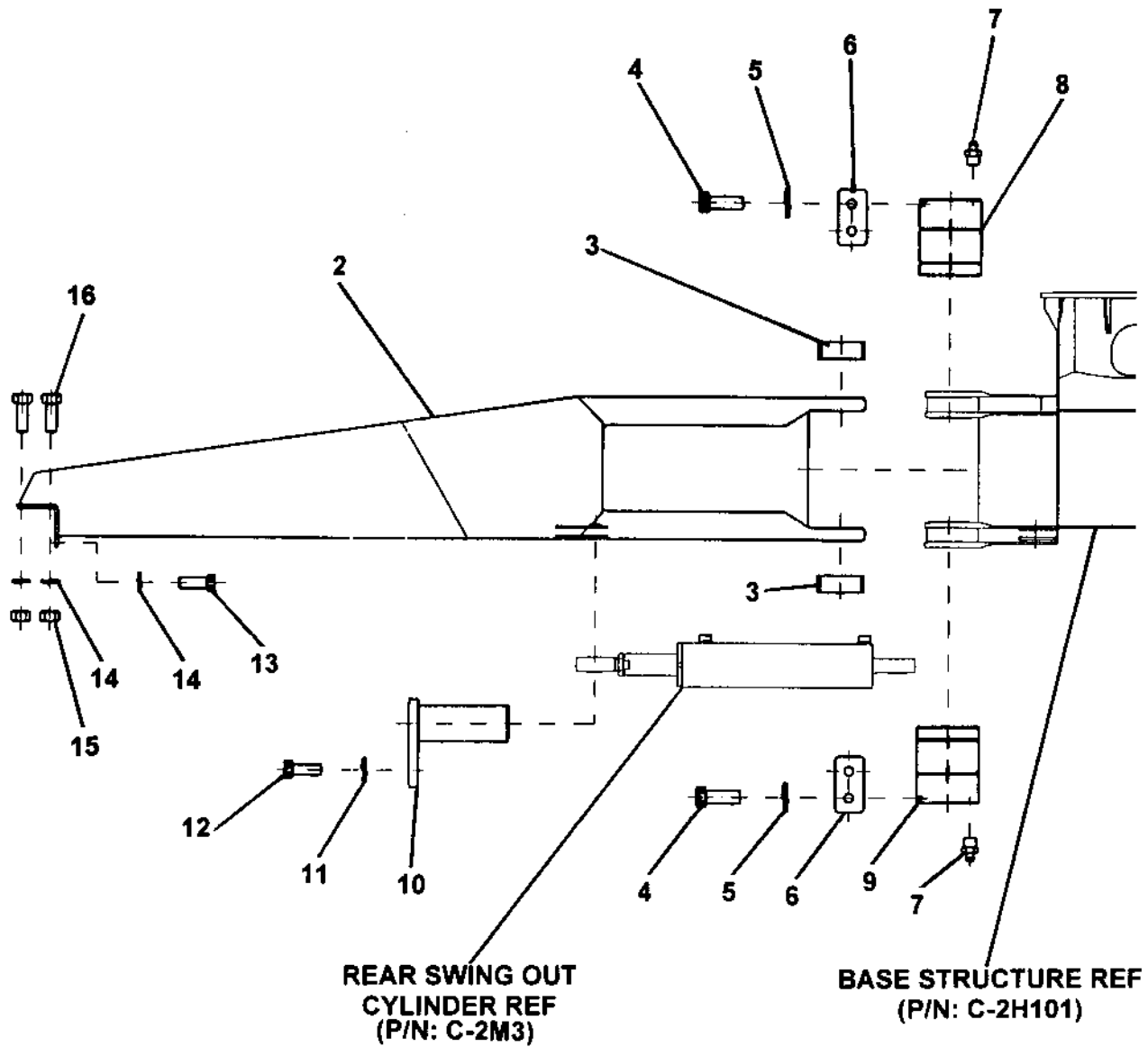
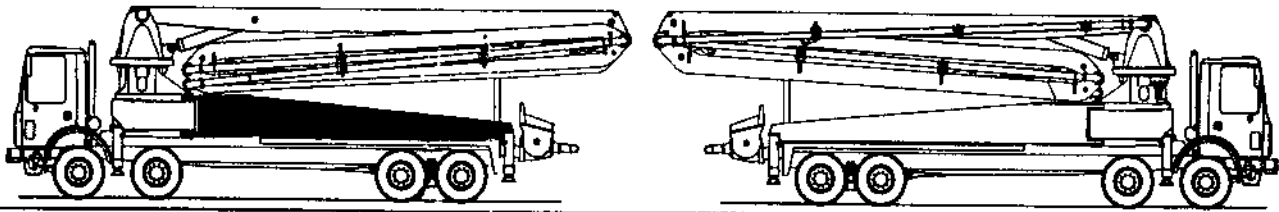

ITEM NO.	REED'S PARTS NO.	DESCRIPTION					QTY
		1	2	3	4	5	
-1	C-2M1-L	Assembly, Rear Left Side Swing Out Leg (See Group 70, Figure 01 for NHA)					Ref
2	C-2M102	• Stabilizer, Rear Left Side					1
3	C-CD200.201080	• Bearing, Anti Friction					2
4	C-VC110.121730	• Screw					4
5	C-UE110.12	• Washer, Elastic					4
6	C-9H107	• Plate, Embed					2
7	C-VI131.1010	• Nipple, Grease					4
8	C-2P203	• Pin, Left Side Top					1
9	C-2P205	• Pin, Left Side Bottom					1
10	C-2P201	• Pin					1
11	C-UE110.08	• Washer, Elastic					1
12	C-VE110.081220	• Screw					1
13	C-VC110.222550	• Screw					2
14	C-UE110.22	• Washer, Elastic					6
15	C-VD111.2225	• Nut					4
16	C-VE110.222580	• Screw					4

DASH (-) ITEM NOT ILLUSTRATED

REAR RIGHT SIDE SWING OUT LEG ASSEMBLY

XXT 42
PARTS
GROUP 70
FIGURE 09
PAGE 01

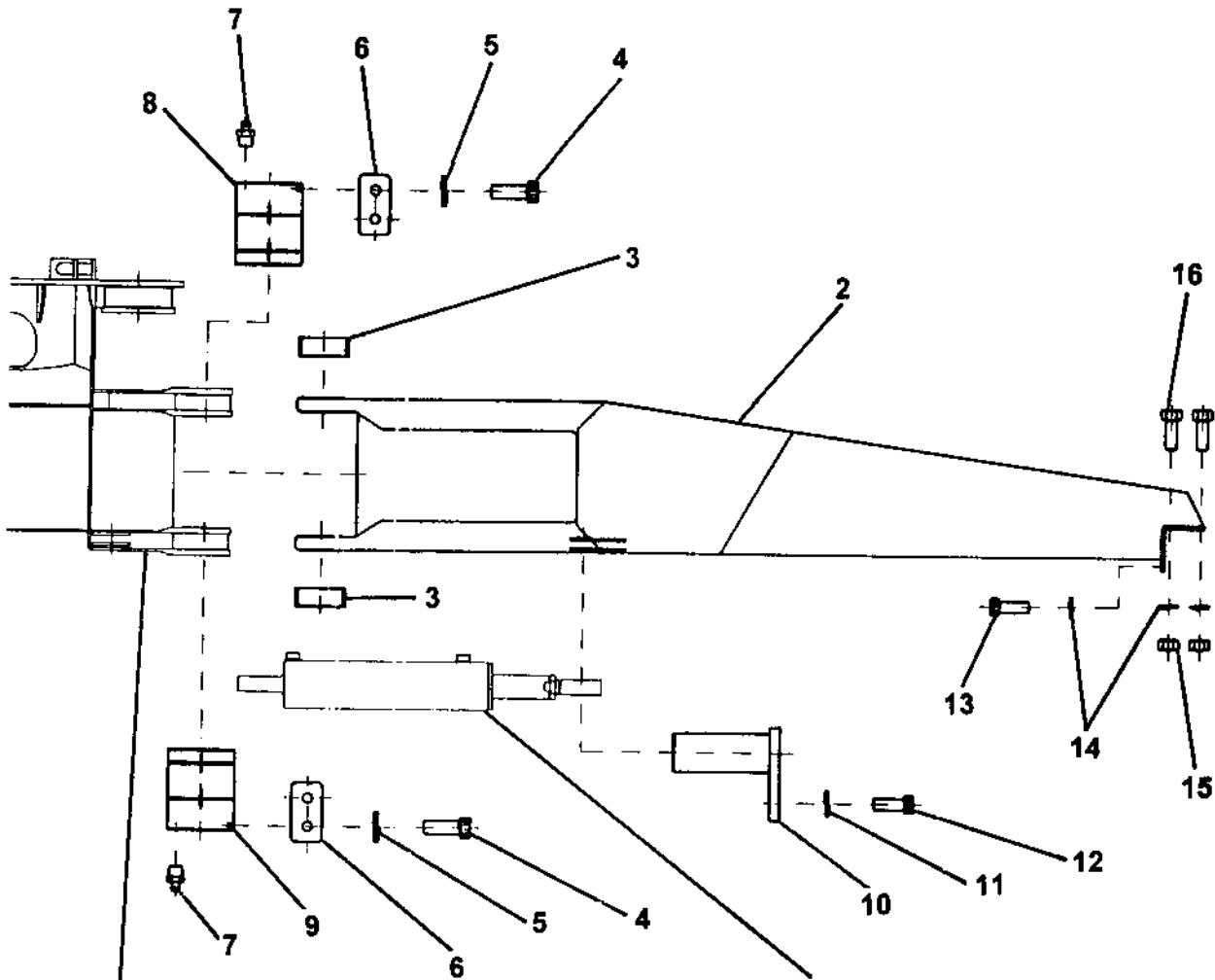
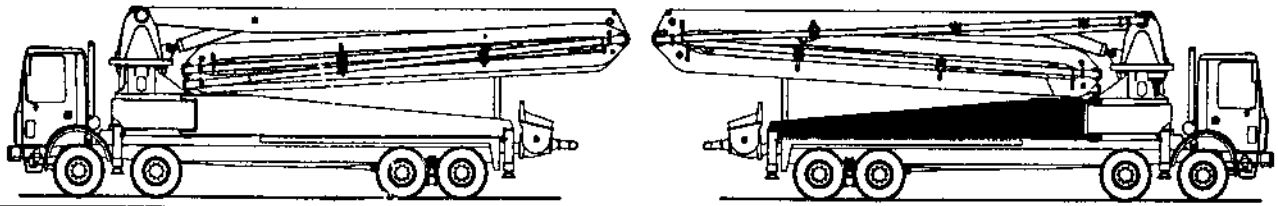

BASE STRUCTURE REF
(P/N: C-2H101)

**REAR SWING OUT
CYLINDER REF**
(P/N: C-2M3)



**REAR RIGHT SIDE
SWING OUT LEG ASSEMBLY**

**XXT 42
PARTS
GROUP 70
FIGURE 09
PAGE 02**

ITEM NO.	REED'S PARTS NO.	DESCRIPTION					QTY
		1	2	3	4	5	
-1	C-2M1-R	Assembly, Rear Right Side Swing Out Leg (See Group 70, Figure 01 for NHA)					Ref
2	C-2M101	• Stabilizer, Rear Right Side					1
3	C-CD200.201080	• Bearing, Anti Friction					2
4	C-VC110.121730	• Screw					4
5	C-UE110.12	• Washer, Elastic					4
6	C-9H107	• Plate, Embed					2
7	C-VI131.1010	• Nipple, Grease					4
8	C-2P204	• Pin, Right Side Top					1
9	C-2P206	• Pin, Right Side Bottom					1
10	C-2P201	• Pin					1
11	C-UE110.08	• Washer, Elastic					1
12	C-VE110.081220	• Screw					1
13	C-VC110.222550	• Screw					2
14	C-UE110.22	• Washer, Elastic					6
15	C-VD111.2225	• Nut					4
16	C-VE110.222580	• Screw					4

DASH (-) ITEM NOT ILLUSTRATED

STABILIZER VERTICAL JACK CYLINDER ASSEMBLY

XXT 42
PARTS
GROUP 70
FIGURE 10
PAGE 01

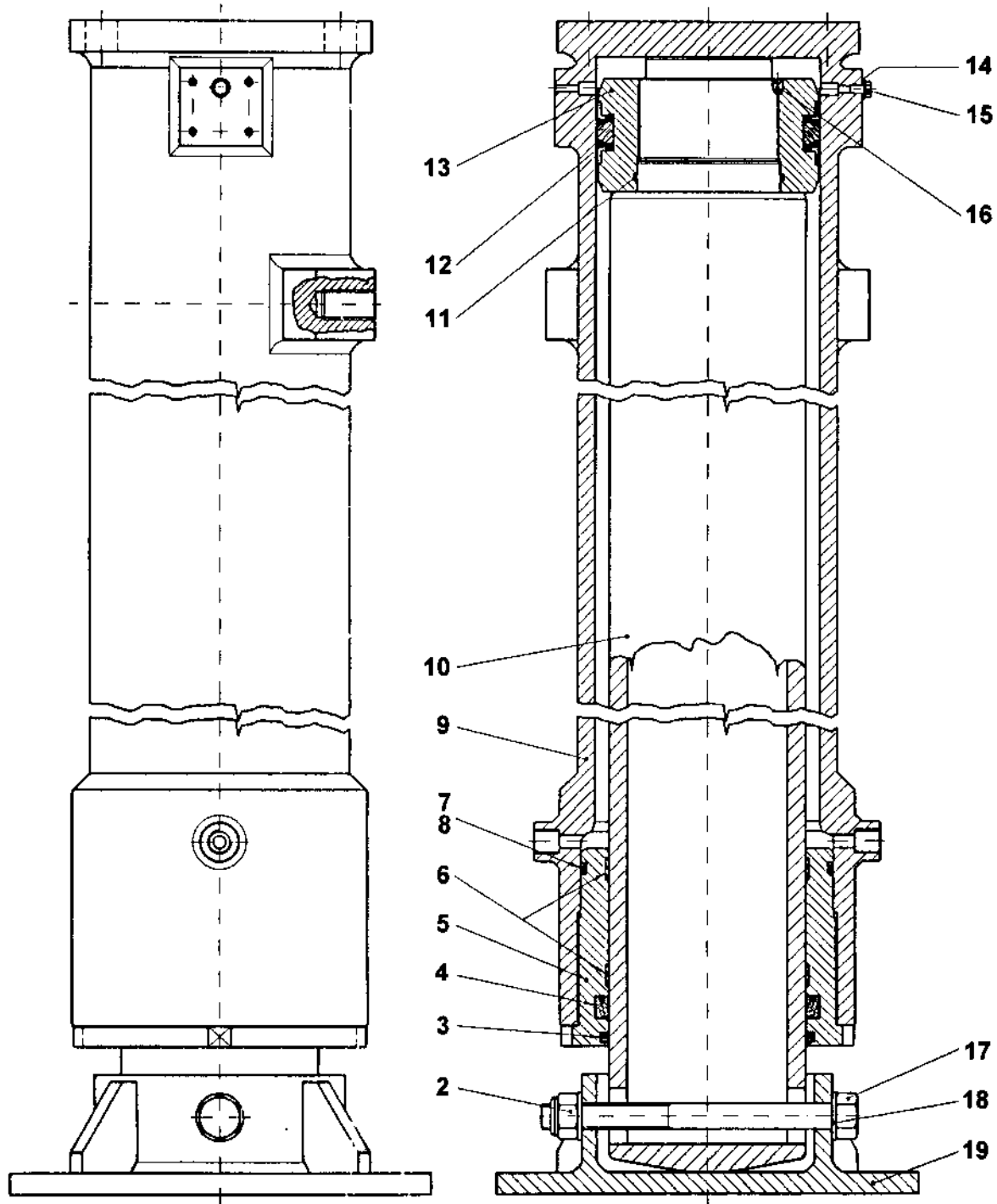
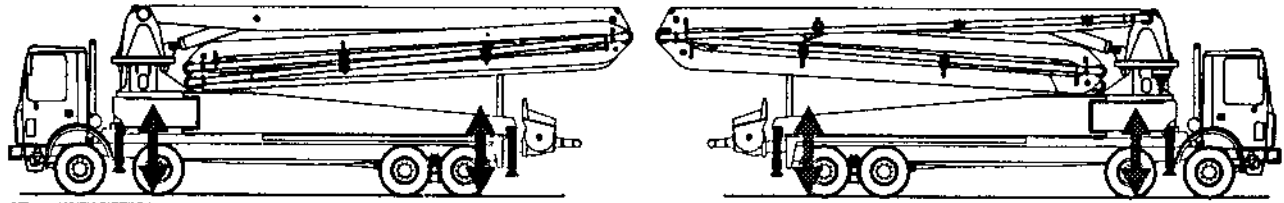

ITEM NO.	REED'S PARTS NO.	DESCRIPTION					QTY
		1	2	3	4	5	
-1	C-2L5	Assembly, Stabilizers Jack Cylinder (See Group 70, Figure 01 for NHA)					Ref
2	C-VD221.1825	• Nut, Self Locking					1
3	C-BR310.140	• Gasket, Seal					1
4	C-BT110.140	• Gasket, Seal					1
5	C-3K501	• Head, Slide Rod					1
6	C-AG123.140	• Ring, Slide Rod					2
7	C-AO120.364	• Gasket, Seal					1
8	C-AP110.364	• Gasket, Seal					1
9	C-2L502	• Cylinder					1
10	C-2L507	• Rod					1
11	C-AO120.242	• Gasket, Seal					1
12	C-BS23629531	• Gasket, Seal					1
13	C-2L512	• Piston					1
14	C-AB110.006	• Ring, Bonded					1
15	C-DT110.16	• Plug, Screw					1
16	C-VG122.081010	• Screw					1
17	C-VE110.1825C8	• Screw, Foot					1
18	C-UP110.18	• Washer, Elastic					2
19	C-2L519	• Foot					1

DASH (-) ITEM NOT ILLUSTRATED

SWING OUT CYLINDER ASSEMBLY

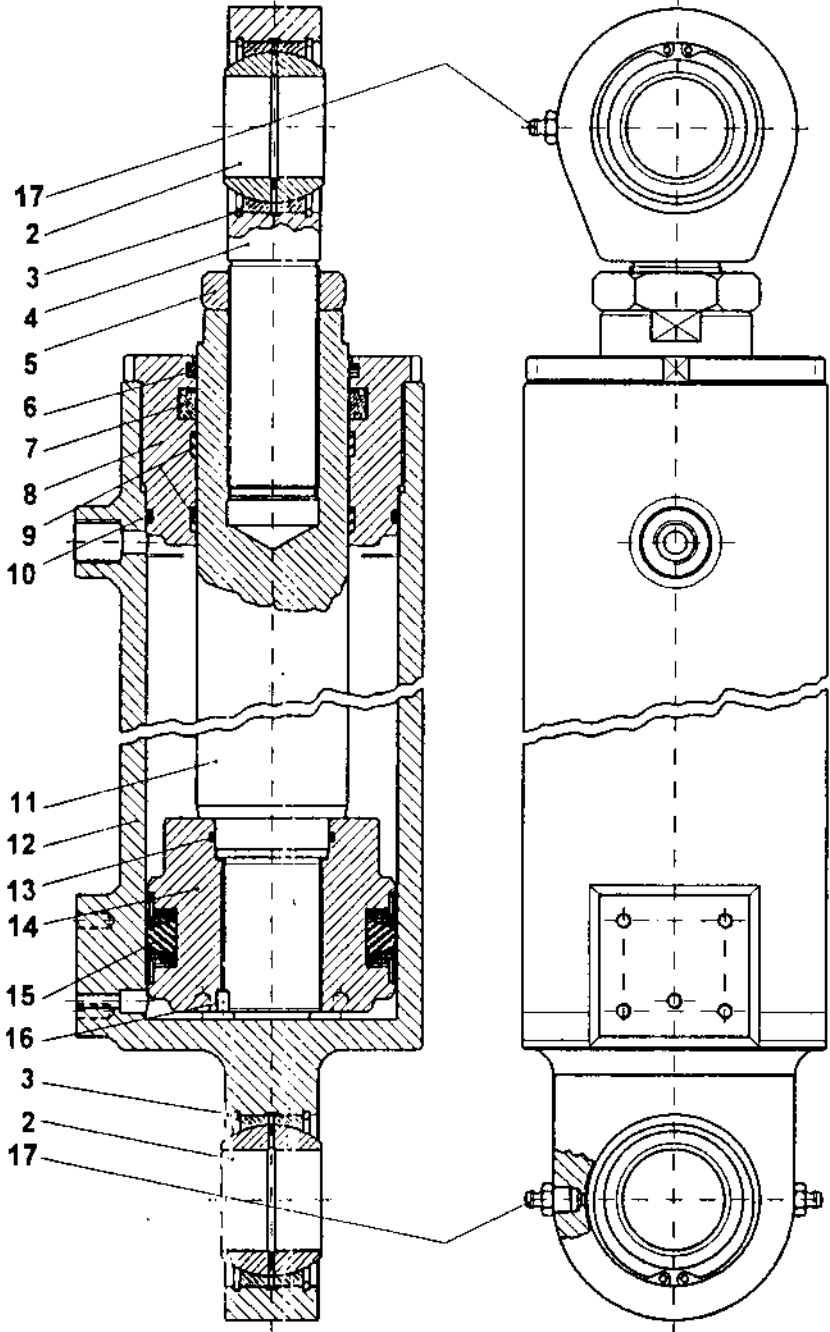
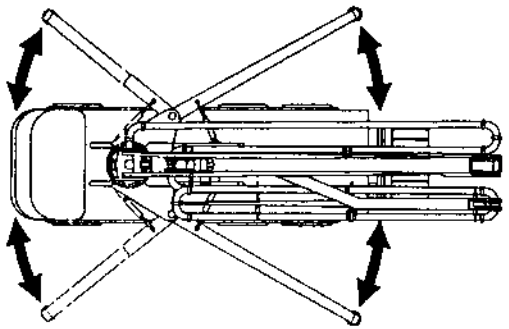

ITEM NO.	REED'S PARTS NO.	1 2 3 4 5	DESCRIPTION	QTY
-1	C-2M3		Assembly, Rear Swing Out Cylinder (See Group 70, Figure 01 for NHA)	Ref
2	C-CT213.040		• Joint, Ball	2
3	C-AA120.068		• Ring, Clamping	4
4	C-2M308		• Cap, Rod	1
5	C-2M325		• Nut	1
6	C-BR210.236267		• Gasket, Seal	1
7	C-BT110.060		• Gasket, Seal	1
8	C-2M312		• Head, Slide Rod	1
9	C-AG122.060		• Ring, Slide Rod	2
10	C-AO420.4362		• Ring, Sealing	1
11	C-2M307		• Rod	1
12	C-2M302		• Cylinder	1
13	C-AO420.3175		• Ring, Sealing	1
14	C-BS23393295		• Gasket, Seal	1
15	C-2M312		• Piston	1
16	C-VG122.061008		• Screw	1
17	C-VI131.1010		• Nipple, Grease	3

DASH (-) ITEM NOT ILLUSTRATED



MODEL *XXT 42* TRUCK MOUNTED
CONCRETE BOOM PUMP
ILLUSTRATED PARTS MANUAL

XXT 42
PARTS
GROUP 70
FIGURE 12
PAGE 01

THIS PAGE INTENTIONALLY LEFT BLANK.

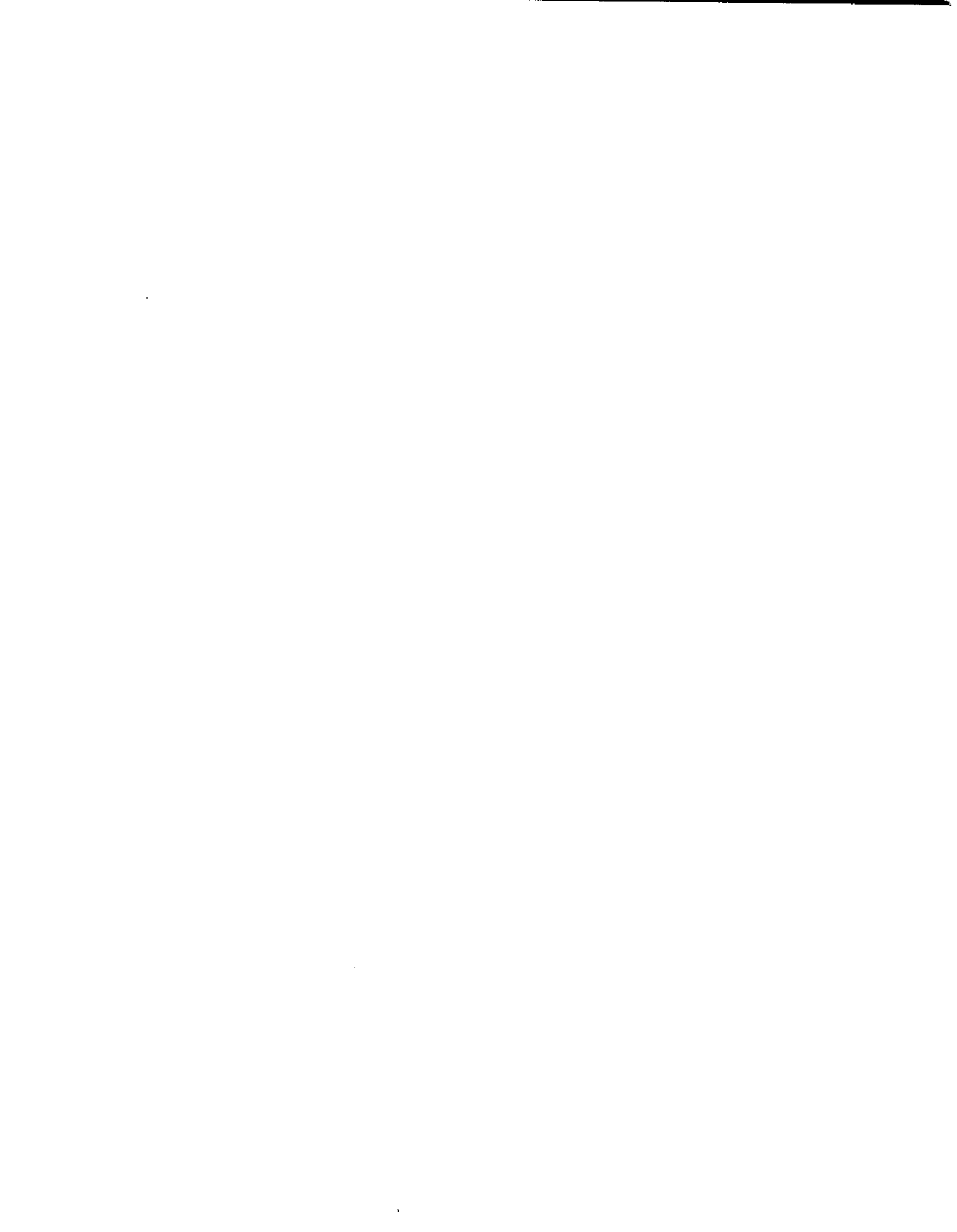

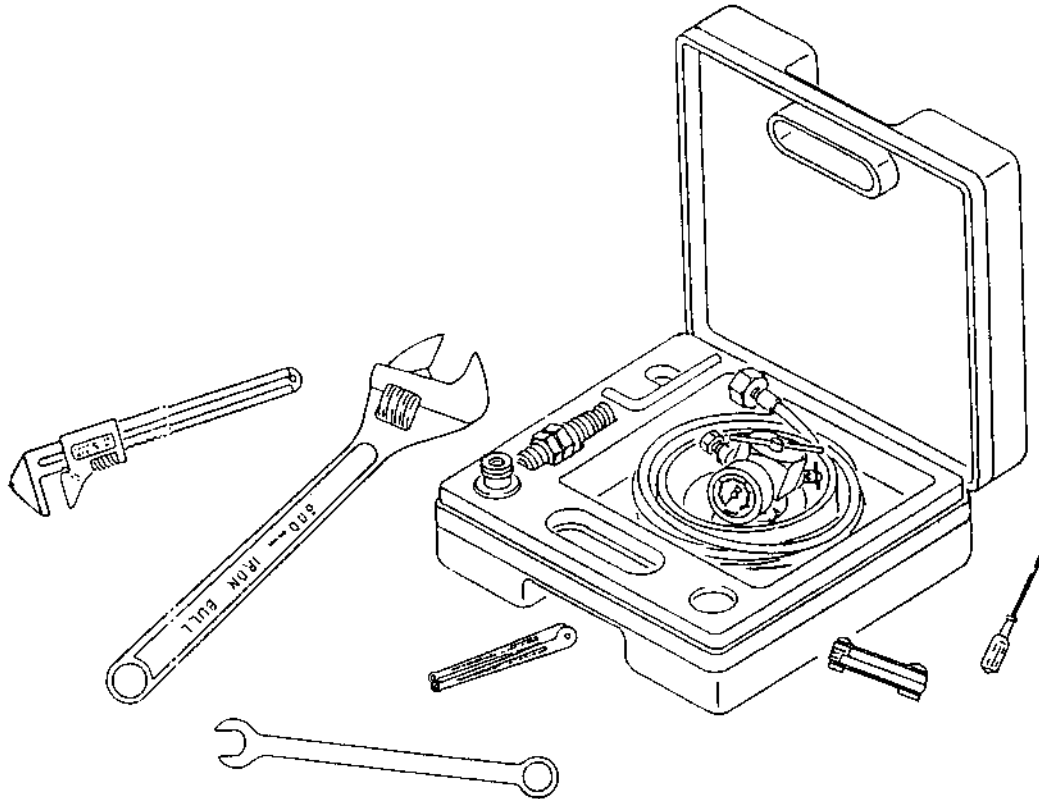

REED TRUCK MOUNTED CONCRETE BOOM PUMP MODEL XXT 42 ILLUSTRATED PARTS MANUAL GROUP 80 OPTIONAL INSTALLATION CONTAINS THE FOLLOWING FIGURES:

- FIGURE 00** TABLE OF CONTENTS
- FIGURE 01** OPTIONAL INSTALLATION
- FIGURE 02** ACCUMULATOR CHARGE KIT
- FIGURE 03** OPTIONAL TOOL KIT ASSEMBLY

REED

OPTIONAL INSTALLATION

XXT 42
PARTS
GROUP 80
FIGURE 01
PAGE 01

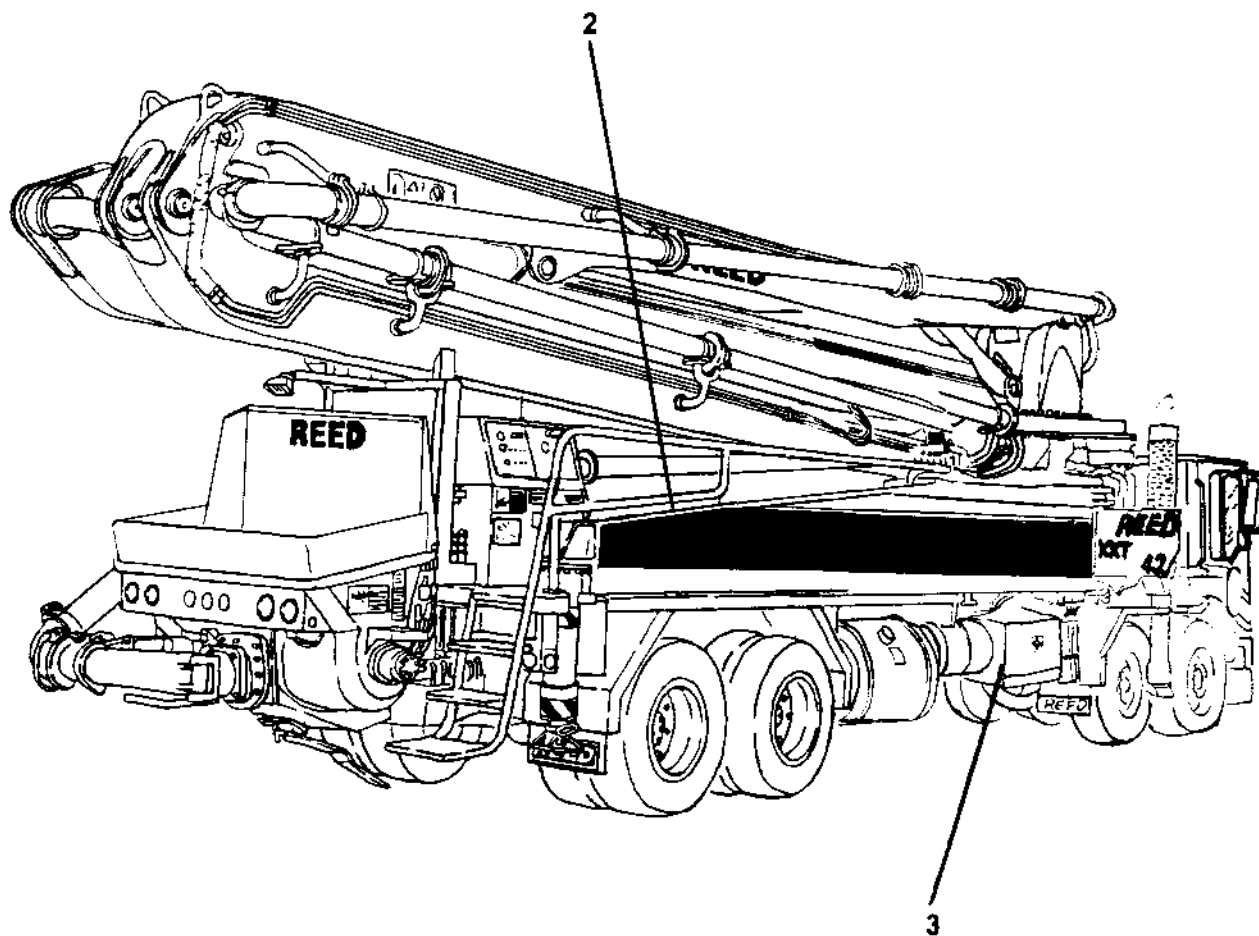



OPTIONAL INSTALLATION

XXT 42
PARTS
GROUP 80
FIGURE 01
PAGE 02

ITEM NO.	REED'S PARTS NO.	1 2 3 4 5	DESCRIPTION	QTY
-1	80-01		Installation, Optional (See Group 10, Figure 01 for NHA)	Ref
2	71460		• Kit, Accumulator Charge (See Group 80, Figure 04 for DET)	1
3	79020		• Assembly, Optional Tool Kit (See Group 80, Figure 06 for DET)	1

DASH (-) ITEM NOT ILLUSTRATED

REED

ACCUMULATOR CHARGE KIT

XXT 42
PARTS
GROUP 80
FIGURE 02
PAGE 01

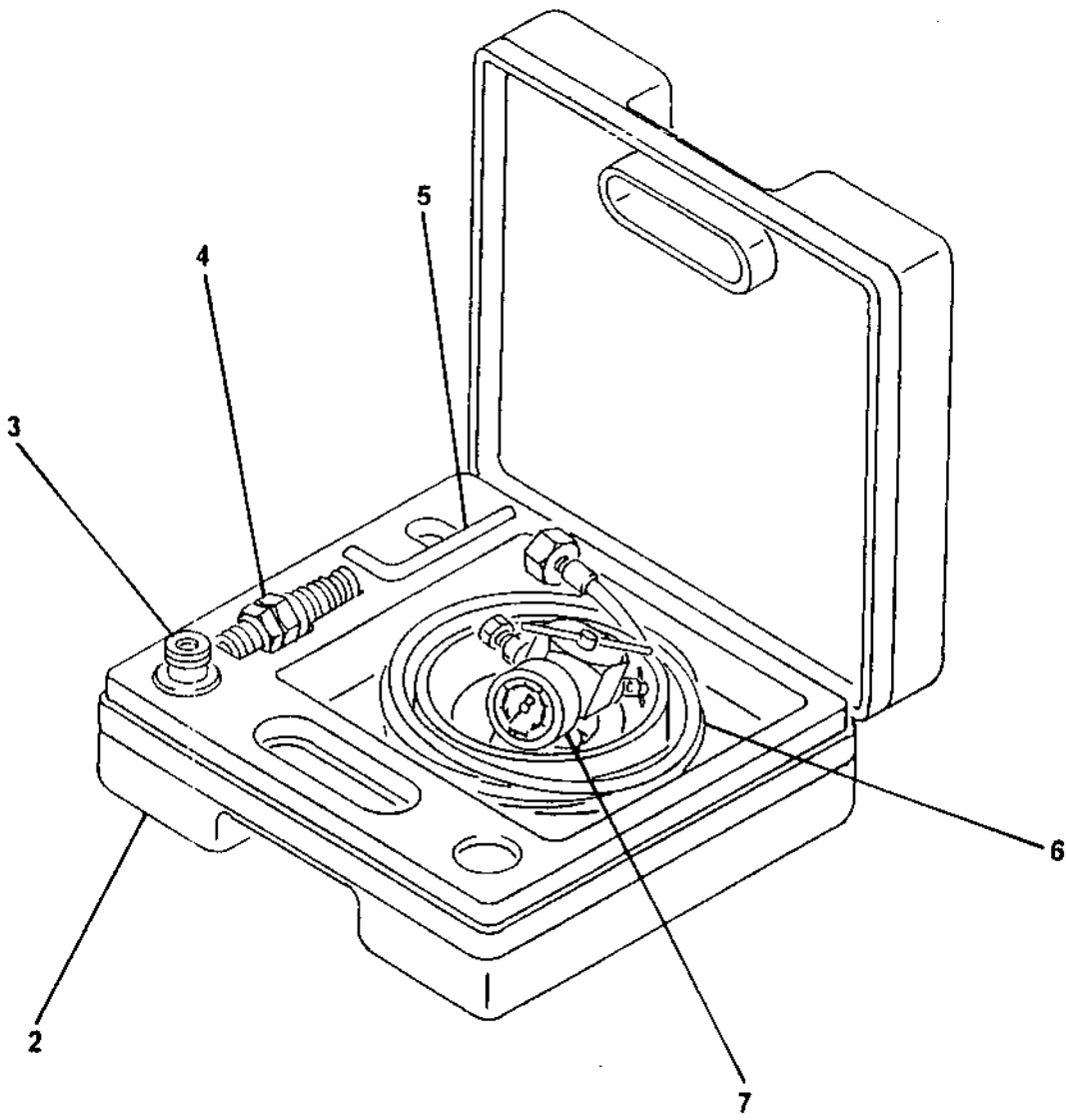

REED**ACCUMULATOR CHARGE KIT****XXT 42**
PARTS
GROUP 80
FIGURE 02
PAGE 02

ITEM NO.	REED'S PARTS NO.	DESCRIPTION					QTY
		1	2	3	4	5	
-1	71460	Kit, Accumulator Charge (See Group 80, Figure 01 for NHA)					Ref
2		• Case, Charge Kit					1
3		• Adapter, FPK / SB					1
4		• Adapter, G4					1
5		• Wrench, Allen					1
6		• Hose, Charging					1
7		• Unit, FPK Charging and Gagging					1

DASH (-) ITEM NOT ILLUSTRATED



OPTIONAL TOOL KIT ASSEMBLY

XXT 42
PARTS
GROUP 80
FIGURE 03
PAGE 01

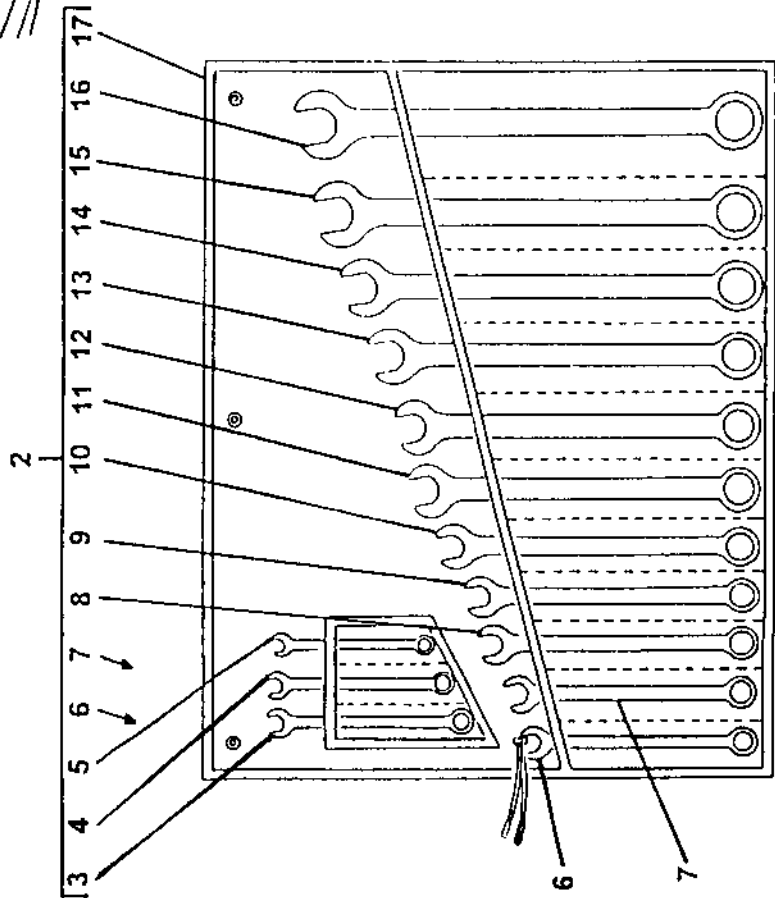
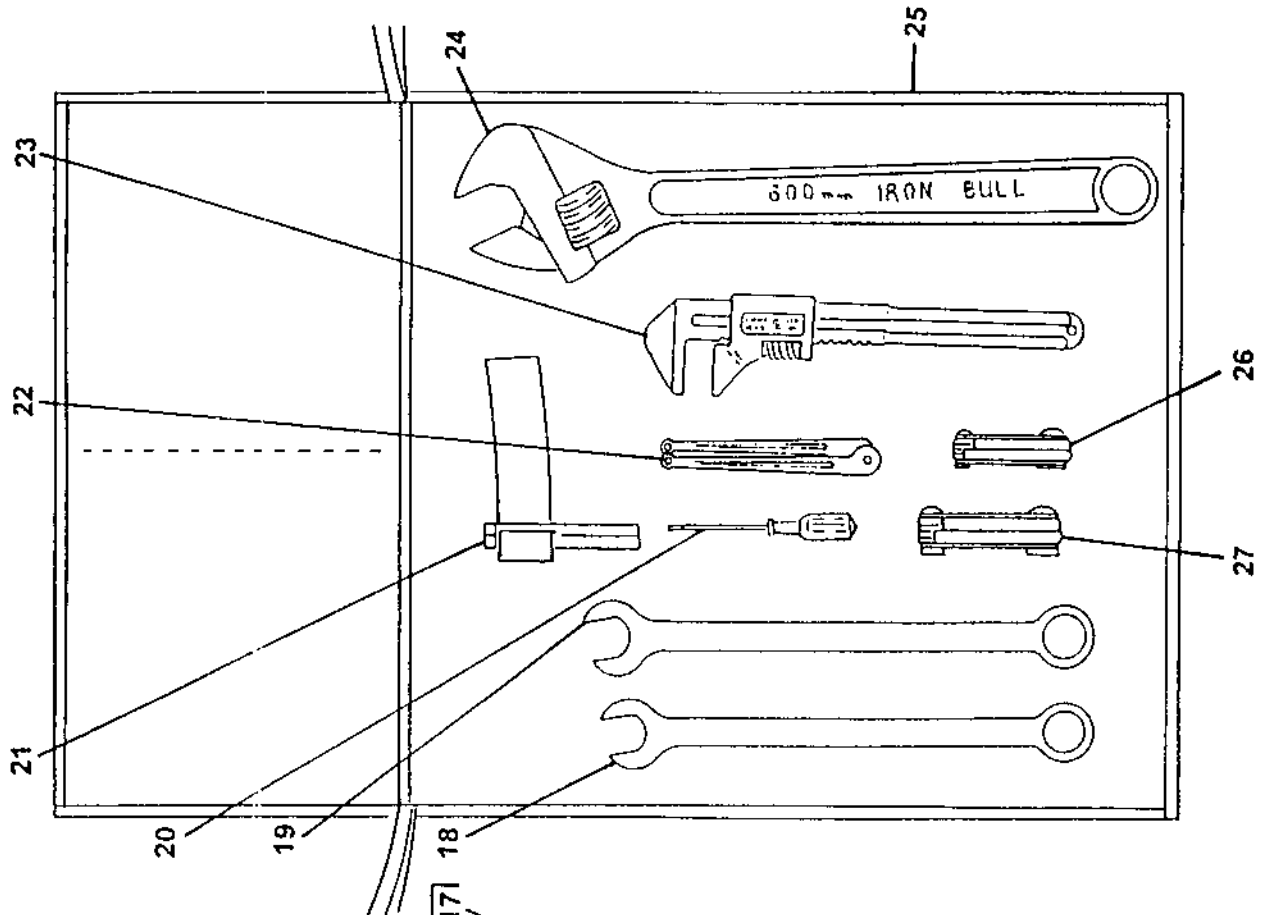

ITEM NO.	REED'S PARTS NO.	DESCRIPTION					QTY
		1	2	3	4	5	
-1	79020	Assembly, Optional Tool Kit (See Group 80, Figure 01 for NHA)					Ref
2	79037	• Kit, Wrench					1
3		• • Wrench, 1/2 Inch					1
4		• • Wrench, 7/16 Inch					1
5		• • Wrench, 3/8 Inch					1
6		• • Wrench, 9/16 Inch					1
7		• • Wrench, 5/8 Inch					1
8		• • Wrench, 11/16 Inch					1
9		• • Wrench, 3/4 Inch					1
10		• • Wrench, 13/16 Inch					1
11		• • Wrench, 7/8 Inch					1
12		• • Wrench, 15/16 Inch					1
13		• • Wrench, 1 Inch					1
14		• • Wrench, 1-1/16 Inch					1
15		• • Wrench, 1-1/8 Inch					1
16		• • Wrench, 1-1/4 Inch					1
17		• • Wrap, Plastic					1
18	79036	• Wrench, 1-3/8 Inch					1
19	79028	• Wrench, 1-1/2 Inch					1
20	79038	• Screwdriver					1
21	79814	• Wrench, Strap (for Filter)					1
22	79325	• Wrench, Spanner					1
23	79031	• Wrench, Monkey					1
24	79032	• Wrench, Adjustable 24 Inch					1
25	77502	• Bag, Tool					1
26	79030	• Set, Metric Allen Key (2-8 mm)					1
27	79029	• Set, Standard Allen Key (3/16-3/8 Inch)					1

DASH (-) ITEM NOT ILLUSTRATED

REED

MODEL *XXT 42* TRUCK MOUNTED
CONCRETE BOOM PUMP
ILLUSTRATED PARTS MANUAL

XXT 42
PARTS
GROUP 80
FIGURE 04
PAGE 01

THIS PAGE INTENTIONALLY LEFT BLANK.



REED TRUCK MOUNTED CONCRETE BOOM PUMP MODEL **XXT 42**
ILLUSTRATED PARTS MANUAL GROUP 90 BOOM INSTALLATION CONTAINS
THE FOLLOWING FIGURES:

- FIGURE 00** TABLE OF CONTENTS
- FIGURE 01** BOOM INSTALLATION
- FIGURE 02** FIRST BOOM ASSEMBLY
- FIGURE 03** SECOND BOOM ASSEMBLY
- FIGURE 04** THIRD BOOM ASSEMBLY
- FIGURE 05** FOURTH BOOM ASSEMBLY
- FIGURE 06** FIRST BOOM CYLINDER ASSEMBLY
- FIGURE 07** SECOND BOOM CYLINDER ASSEMBLY
- FIGURE 08** THIRD BOOM CYLINDER ASSEMBLY
- FIGURE 09** FOURTH BOOM CYLINDER ASSEMBLY
- FIGURE 10** CONCRETE PIPELINE ASSEMBLY (DECK AREA)
- FIGURE 11** CONCRETE PIPELINE ASSEMBLY (BOOM AREA)

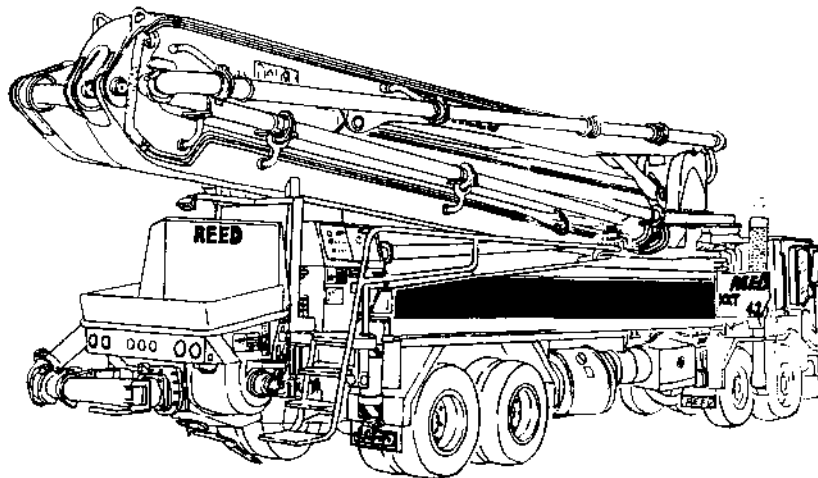



BOOM INSTALLATION

XXT 42
PARTS
GROUP 90
FIGURE 01
PAGE 01

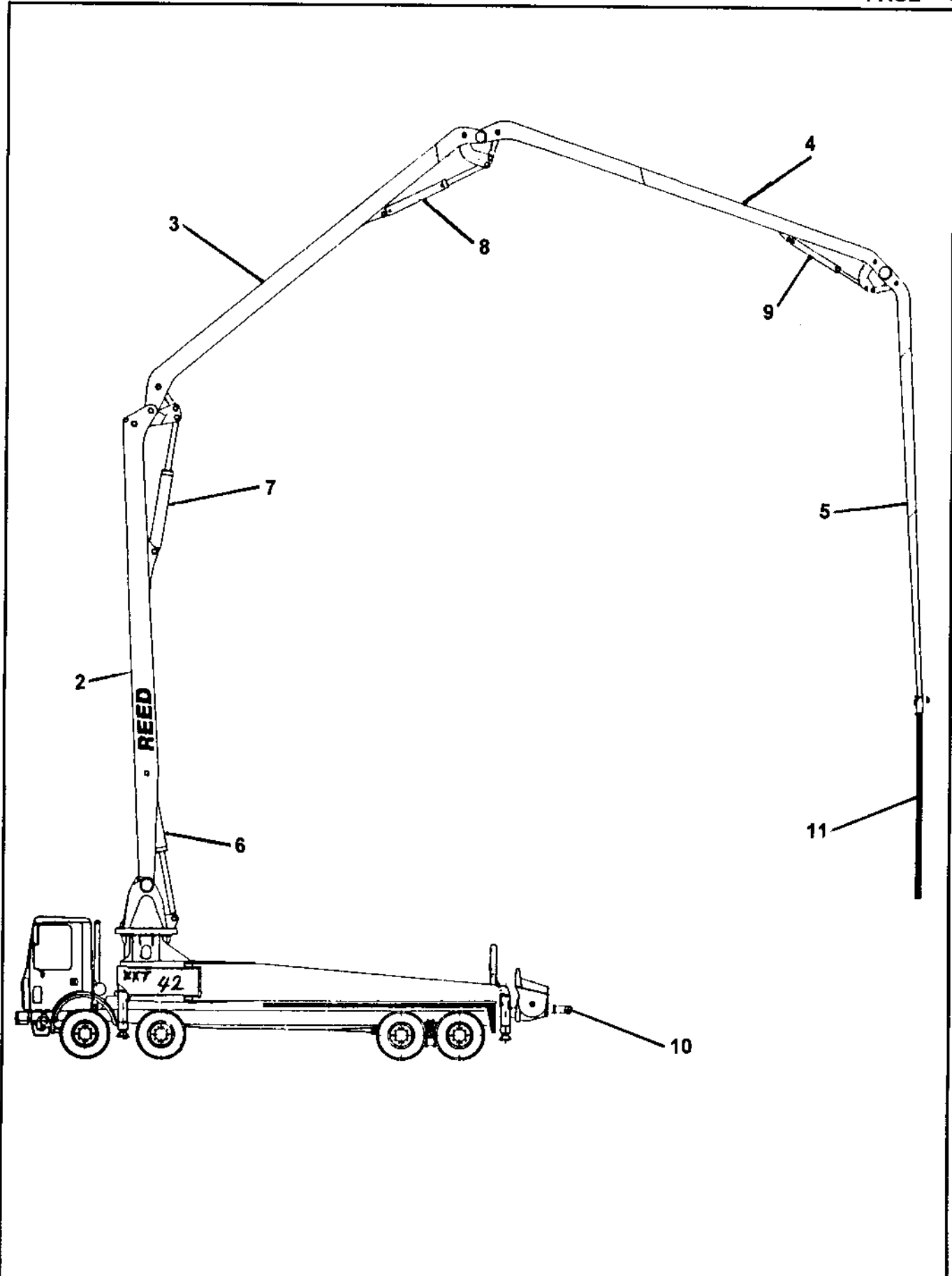

REVISION:

ITEM NO.	REED'S PARTS NO.	DESCRIPTION					QTY
		1	2	3	4	5	
-1	90-01	Installation, Boom (See Group 10, Figure 01 for NHA)					Ref
2	C-2A1	• Assembly, First Boom (See Group 90, Figure 02 for DET)					1
3	C-2A2	• Assembly, Second Boom (See Group 90, Figure 03 for DET)					1
4	C-2A3	• Assembly, Third Boom (See Group 90, Figure 04 for DET)					1
5	C-2A4	• Assembly, Fourth Boom (See Group 90, Figure 05 for DET)					1
6	C-2B1	• Assembly, First Boom Cylinder (See Group 90, Figure 06 for DET)					1
7	C-2B2	• Assembly, Second Boom Cylinder (See Group 90, Figure 07 for DET)					1
8	C-2B3	• Assembly, Third Boom Cylinder (See Group 90, Figure 08 for DET)					1
9	C-2B4	• Assembly, Fourth Boom Cylinder (See Group 90, Figure 09 for DET)					1
10	90-10	• Assembly, Concrete Pipe Line (Deck Area) (See Group 90, Figure 10 for DET)					1
11	C-2T	• Assembly, Concrete Pipe Line (Boom Area) (See Group 90, Figure 11 for DET)					1

DASH (-) ITEM NOT ILLUSTRATED

FIRST BOOM ASSEMBLY

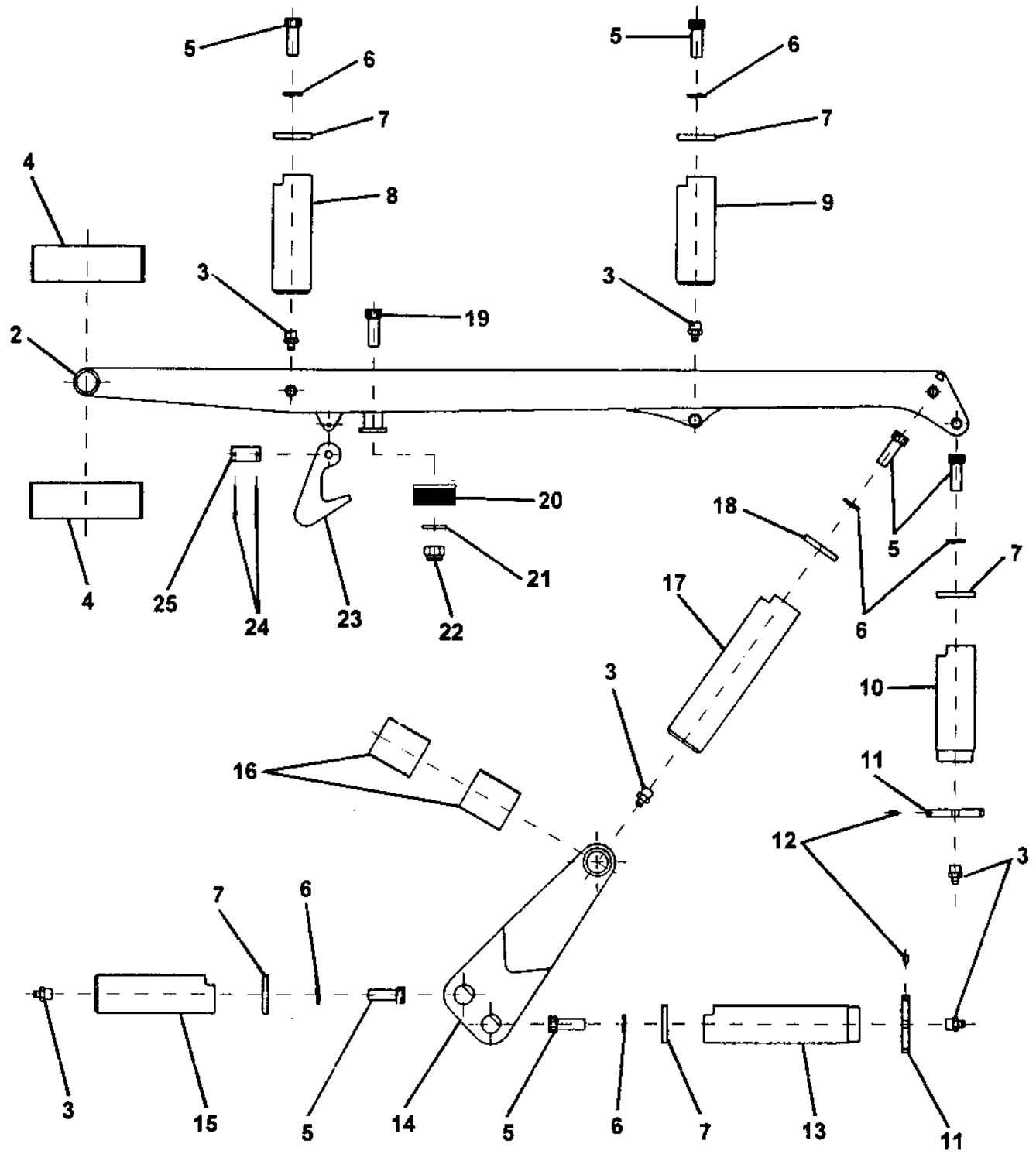
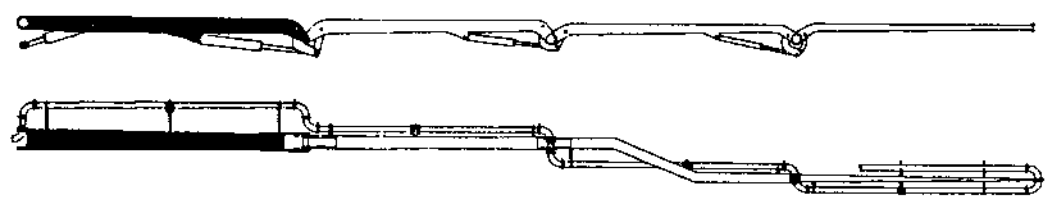

ITEM NO.	REED'S PARTS NO.	DESCRIPTION					QTY
		1	2	3	4	5	
-1	C-2A1	Assembly, First Boom (See Group 90, Figure 01 for NHA)					Ref
2	C-2A101	• Structure, Base					1
3	C-VI131.1010	• Nipple, Grease					7
4	C-CD230.235100	• Bearing, Anti-friction					2
5	C-VC110.101525	• Screw					7
6	C-UE110.10	• Washer, Elastic					7
7	C-UD090.1106	• Washer, Pin Locking					5
8	C-2P111	• Pin					1
9	C-5P103	• Pin					1
10	C-2P115	• Pin					2
11	C-GV085.2015	• Ring, Thread					3
12	C-VG122.061010	• Screw					4
13	C-2P113	• Pin					1
14	C-2C101	• Beam					1
15	C-2P114	• Pin					1
16	C-CD100.105100	• Bearing, Anti-friction					2
17	C-2P116	• Pin					1
18	C-UD090.1106	• Washer, Pin Locking					3
19	C-VC110.101530	• Screw					2
20	C-UG440.170100	• Pad, Rubber					1
21	C-UP110.10	• Washer					2
22	C-VD221.1015	• Nut, Self Locking					2
23	C-4A103	• Hook					1
24	C-VS110.04050	• Pin, Split					2
25	802069	• Pin-Hook					1

DASH (-) ITEM NOT ILLUSTRATED

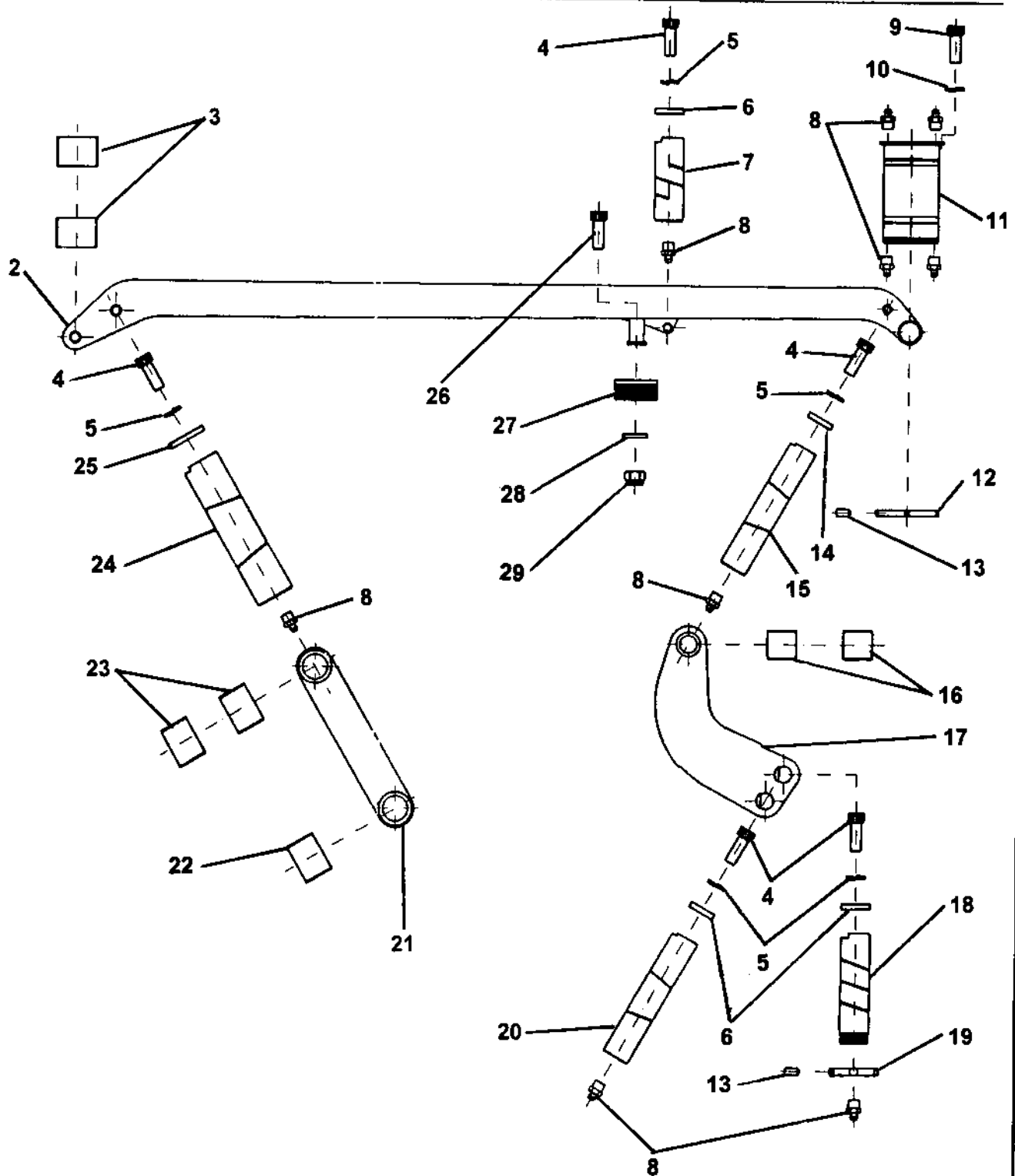
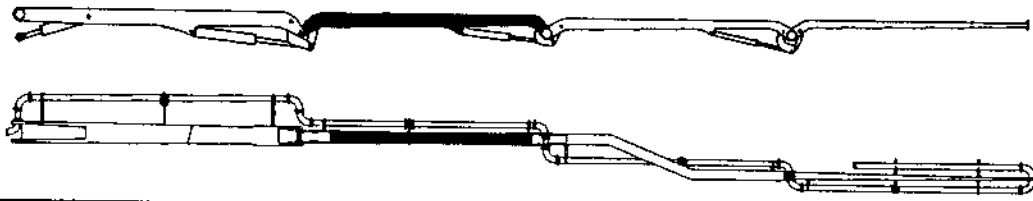

ITEM NO.	REED'S PARTS NO.	DESCRIPTION					QTY
		1	2	3	4	5	
-1	C-2A2	Assembly, Second Boom (See Group 90, Figure 01 for NHA)					Ref
2	C-2A201	• Structure, Base					1
3	C-CD095.100080	• Bearing, Anti-friction					2
4	C-VC110.101525	• Screw					5
5	C-UE110.10	• Washer, Elastic					5
6	C-UD070.1105	• Washer, Pin Locking					3
7	C-2P111	• Pin					1
8	C-VI131.1010	• Nipple, Grease					9
9	C-VC110.081220	• Screw					4
10	C-UE110.08	• Washer, Elastic					4
11	C-2P110	• Pin					1
12	C-GV218.2015	• Ring, Thread					1
13	C-VG122.061010	• Screw					4
14	C-UD080.1106	• Washer, Pin Locking					1
15	C-2P109	• Pin					1
16	C-CD080.085100	• Bearing, Anti-friction					2
17	C-2C201	• Beam					1
18	C-2P108	• Pin					1
19	C-GV070.2015	• Ring, Thread					1
20	C-2P112	• Pin					1
21	C-2D101	• Rod, Connecting					1
22	C-CD090.095120	• Bearing, Anti-friction					1
23	C-CD090.095100	• Bearing, Anti-friction					2
24	C-2P118	• Pin					1
25	C-UD090.1106	• Washer, Pin Locking					1
26	C-VC110.101530	• Screw					2
27	C-UG410.170100	• Pad, Rubber					1
28	C-UP110.10	• Washer					2
29	C-VD221.1015	• Nut, Self Locking					2

DASH (-) ITEM NOT ILLUSTRATED

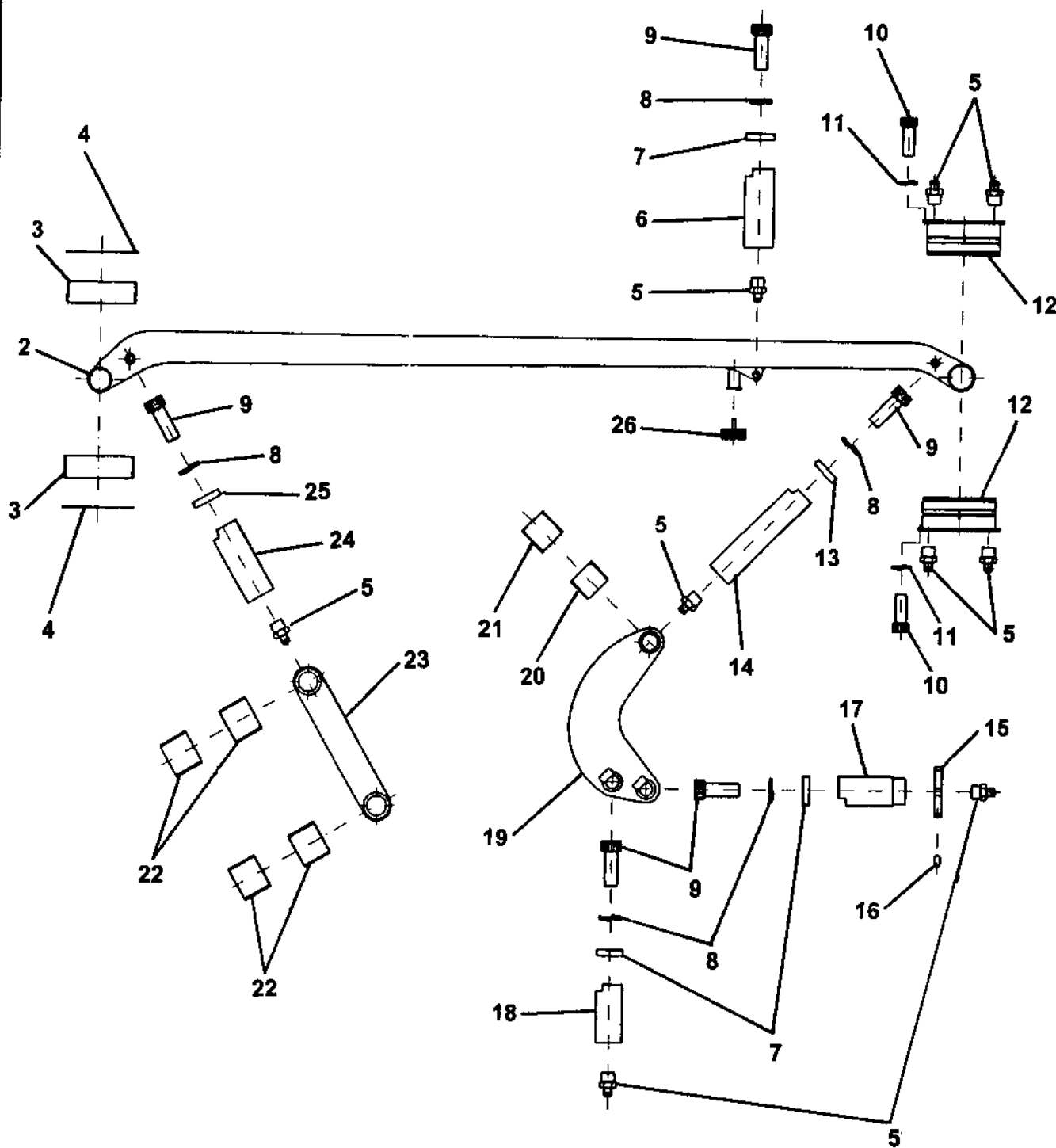
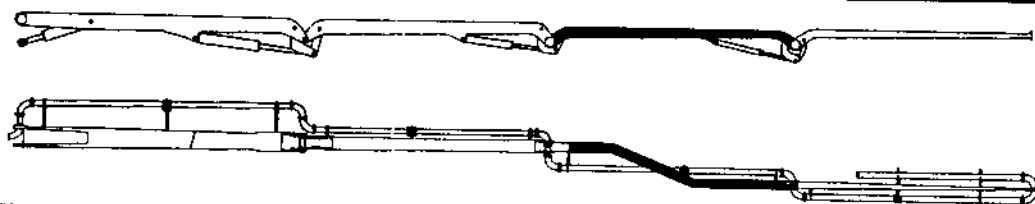

ITEM NO.	REED'S PARTS NO.	DESCRIPTION					QTY
		1	2	3	4	5	
-1	C-2A3	Assembly, Third Boom (See Group 90, Figure 01 for NHA)					Ref
2	C-2A301	• Structure, Base					1
3	C-CD220.225060	• Bearing, Anti-friction					2
4	C-CR220.02	• Ring, Wear					2
5	C-VI131.1010	• Nipple, Grease					9
6	C-2P101	• Pin					1
7	C-UD055.1105	• Washer, Pin Locking					3
8	C-UE110.10	• Washer, Elastic					5
9	C-VC110.101525	• Screw					5
10	C-VE110.081220	• Screw					8
11	C-UE110.08	• Washer, Elastic					8
12	C-4P105B	• Pin					2
13	C-UD06.1105	• Washer, Pin Locking					1
14	C-2P104	• Pin					1
15	C-GV050.1515	• Ring, Threaded					1
16	C-VG122.061010	• Screw					2
17	C-2P102	• Pin					1
18	C-2P103	• Pin					1
19	C-2C301	• Beam					1
20	C-CD060.065060	• Bearing, Anti-friction					2
21	C-CD060.065070	• Bearing, Anti-friction					1
22	C-CD075.080060	• Bearing, Anti-friction					1
23	C-2D201	• Rod, Connecting					1
24	C-2P107	• Pin					1
25	C-UD070.1105	• Washer, Pin Locking					1
26	UG220.10012	• Pad, Rubber					1

DASH (-) ITEM NOT ILLUSTRATED

FOURTH BOOM ASSEMBLY

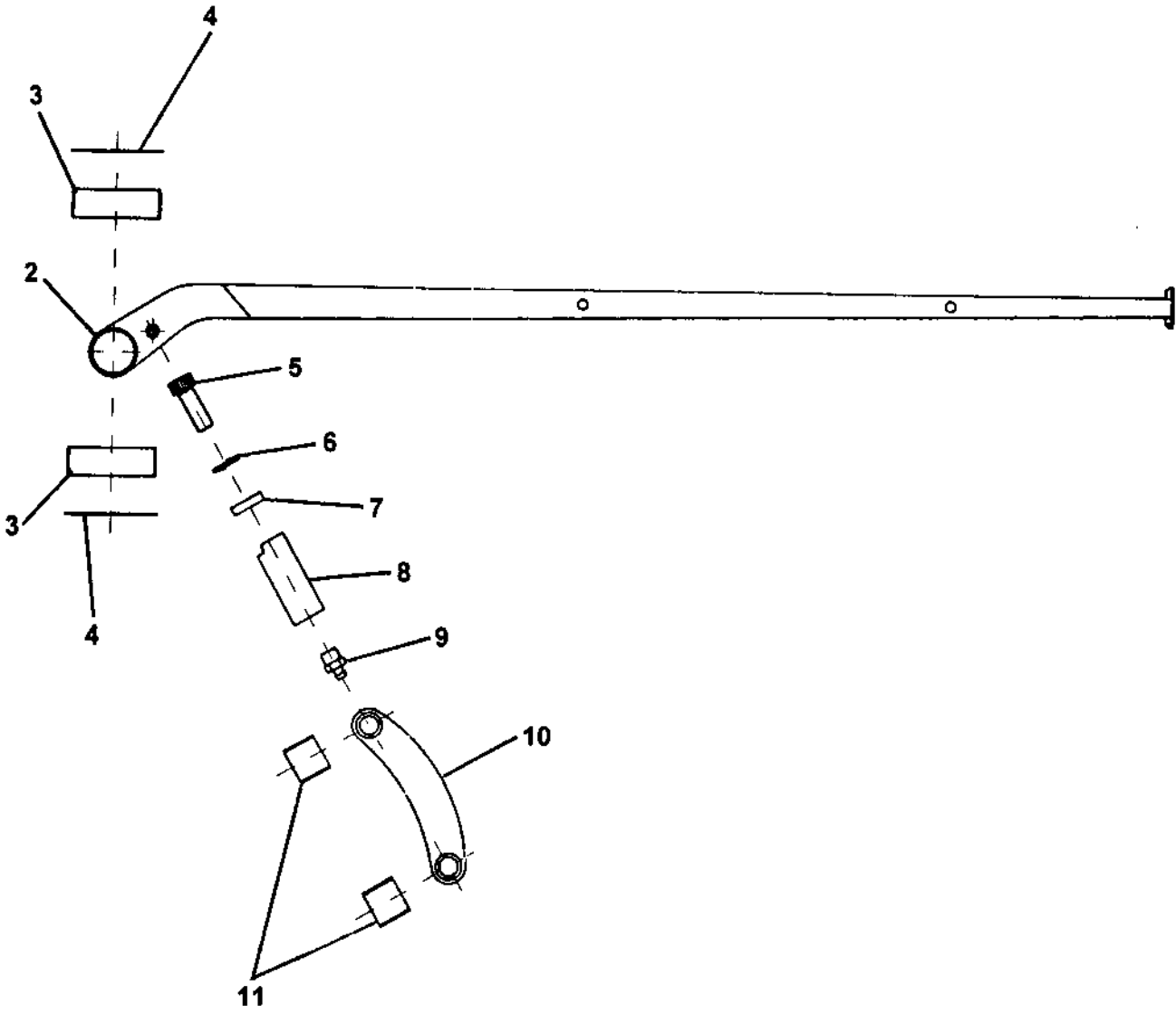
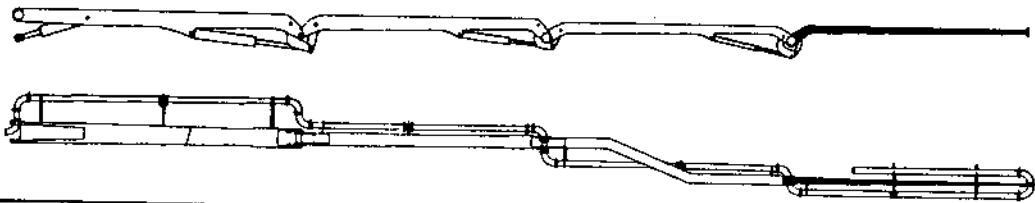

ITEM NO.	REED'S PARTS NO.	DESCRIPTION					QTY
		1	2	3	4	5	
-1	C-2A4	Assembly, Fourth Boom (See Group 90, Figure 01 for NHA)					Ref
2	C-2A401	• Structure, Base					1
3	C-CD250.255040	• Bearing, Anti-friction					2
4	C-CR250.02	• Ring, Wear					2
5	C-VC110.101525	• Screw					1
6	C-UE110.10	• Washer, Elastic					1
7	C-UD050.1105	• Washer, Pin Locking					1
8	C-2P101	• Pin					1
9	C-VI131.1010	• Nipple, Grease					3
10	C-2D301	• Rod, Connection					1
11	C-CD055.055050	• Bearing, Anti-friction					2

DASH (-) ITEM NOT ILLUSTRATED

FIRST BOOM CYLINDER ASSEMBLY

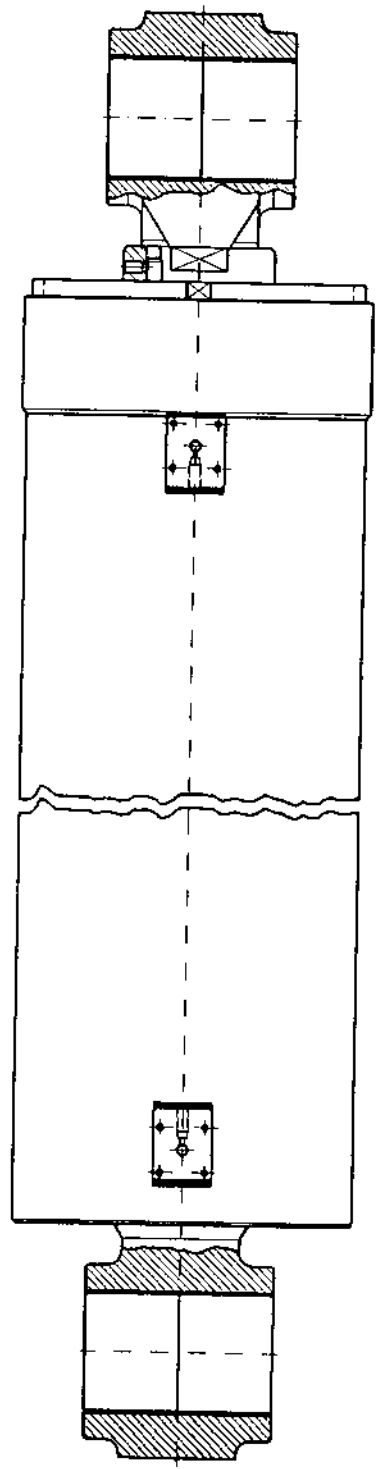
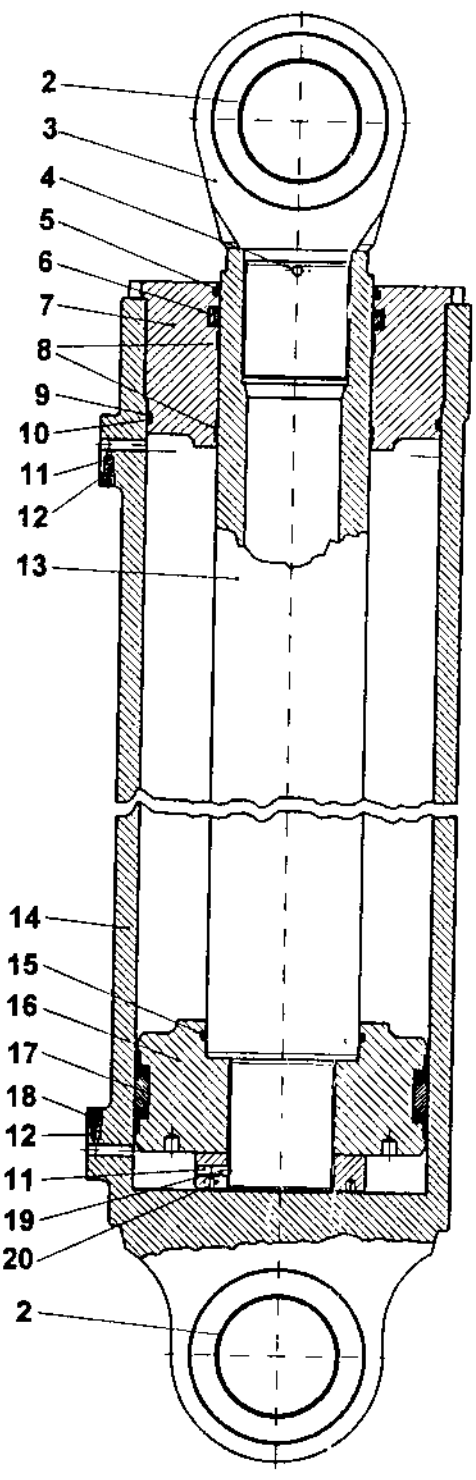
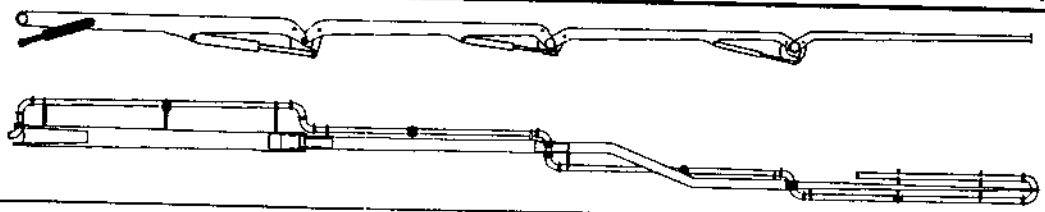



FIRST BOOM CYLINDER ASSEMBLY

XXT 42
PARTS
GROUP 90
FIGURE 06
PAGE 02

ITEM NO.	REED'S PARTS NO.	DESCRIPTION	QTY
-1	C-2B1	Assembly, First Boom Cylinder (See Group 90, Figure 01 for NHA)	Ref
2	C-CD100.105080	• Bearing, Anti Friction	4
3	C-2B108	• Cap, Rod	1
4	C-VG122.101515	• Screw	1
5	C-BR310.130	• Gasket, Seal	1
6	C-BT110.130	• Gasket, Seal	1
7	C-5B101	• Head, Slide Rod	1
8	C-AG123.130	• Ring, Slide Rod	2
9	C-AP110.375	• Seal, Gasket	1
10	C-AO120.375	• Ring, Sealing	1
11	C-VG121.081212	• Screw	1
12	C-CS100.007	• Ball, Still	2
13	C-2B107	• Rod	1
14	C-2B102	• Cylinder	1
15	C-AO420.1208	• Ring, Sealing	1
16	C-2B112	• Piston	1
17	C-BS229848801A	• Gasket, Seal	1
18	C-WPVS1	• Valve, Air Hole	2
19	C-VG122.081215	• Screw	1
20	C-2B105	• Nut, Rod	1

DASH (-) ITEM NOT ILLUSTRATED

SECOND BOOM CYLINDER ASSEMBLY

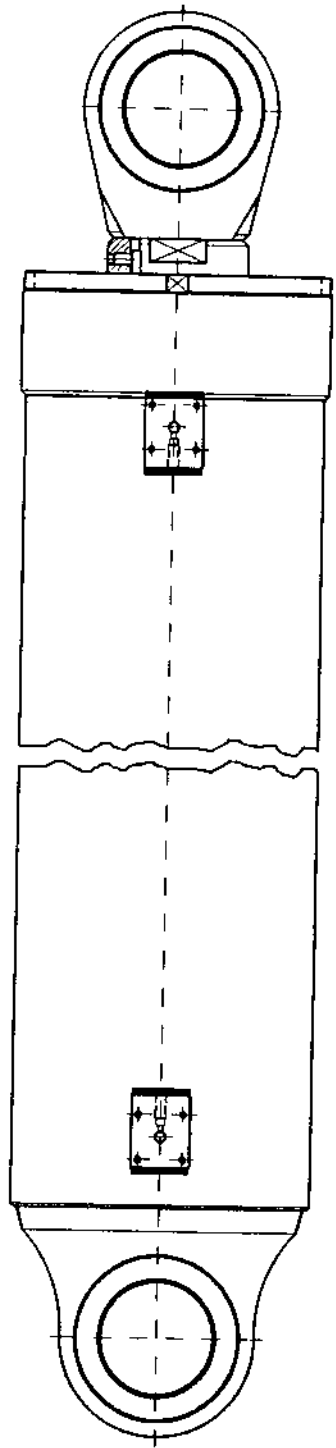
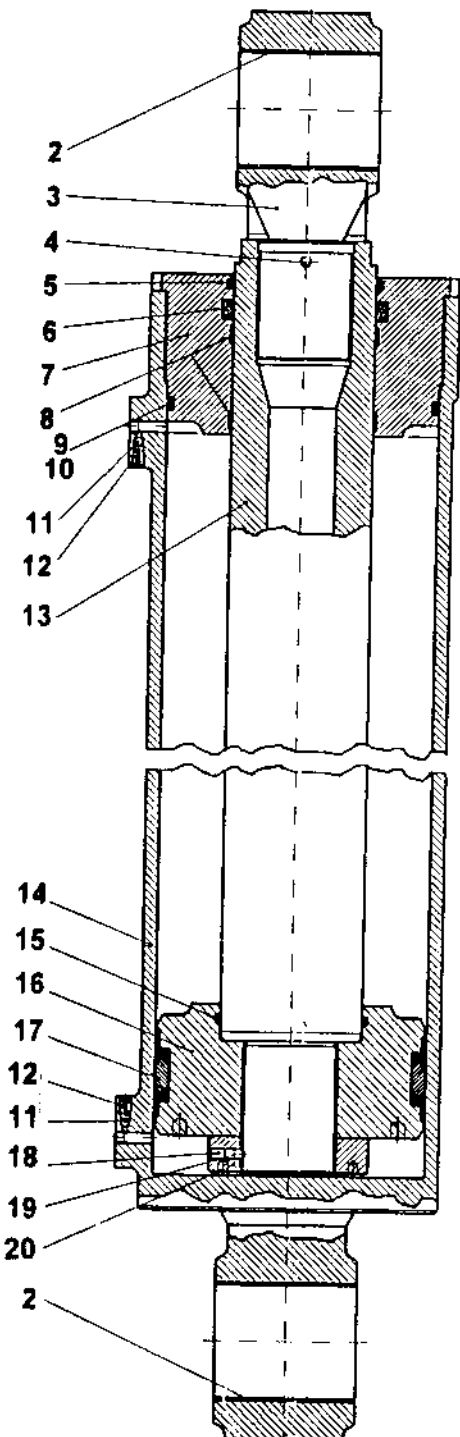
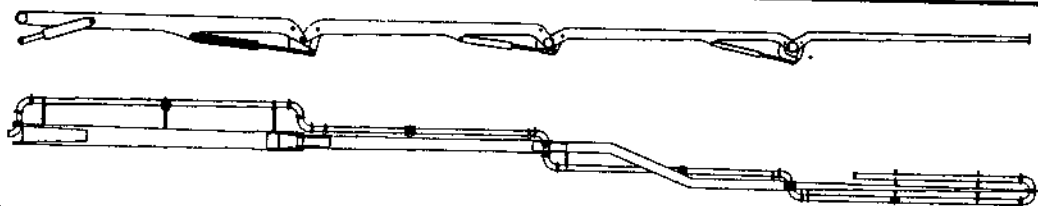

ITEM NO.	REED'S PARTS NO.	DESCRIPTION					QTY
		1	2	3	4	5	
-1	C-2B2	Assembly, Second Boom Cylinder (See Group 90, Figure 01 for NHA)					Ref
2	C-CD095.100060	• Bearing, Anti Friction					4
3	C-2B208	• Cap, Rod					1
4	C-VG122.101515	• Screw					1
5	C-BR310.120	• Gasket, Seal					1
6	C-BT110.120	• Gasket, Seal					1
7	C-2B201	• Head, Slide Rod					1
8	C-AG123.120	• Ring, Slide Rod					2
9	C-AO120.372	• Ring, Sealing					1
10	C-AP110.372	• Seal, Gasket					1
11	C-CS100.007	• Ball, Steel					2
12	C-WPVS1	• Valve, Air Hole					2
13	C-2B207	• Rod					1
14	C-3B202	• Cylinder					1
15	C-AO420.199	• Ring, Sealing					1
16	C-2B212	• Piston					1
17	C-BS229058071A	• Ring, Sealing					1
18	C-VG121.081212	• Screw					1
19	C-VG122.081215	• Screw					1
20	C-2B209	• Nut, Rod					1

DASH (-) ITEM NOT ILLUSTRATED



THIRD BOOM CYLINDER ASSEMBLY

XXT 42
PARTS
GROUP 90
FIGURE 08
PAGE 01

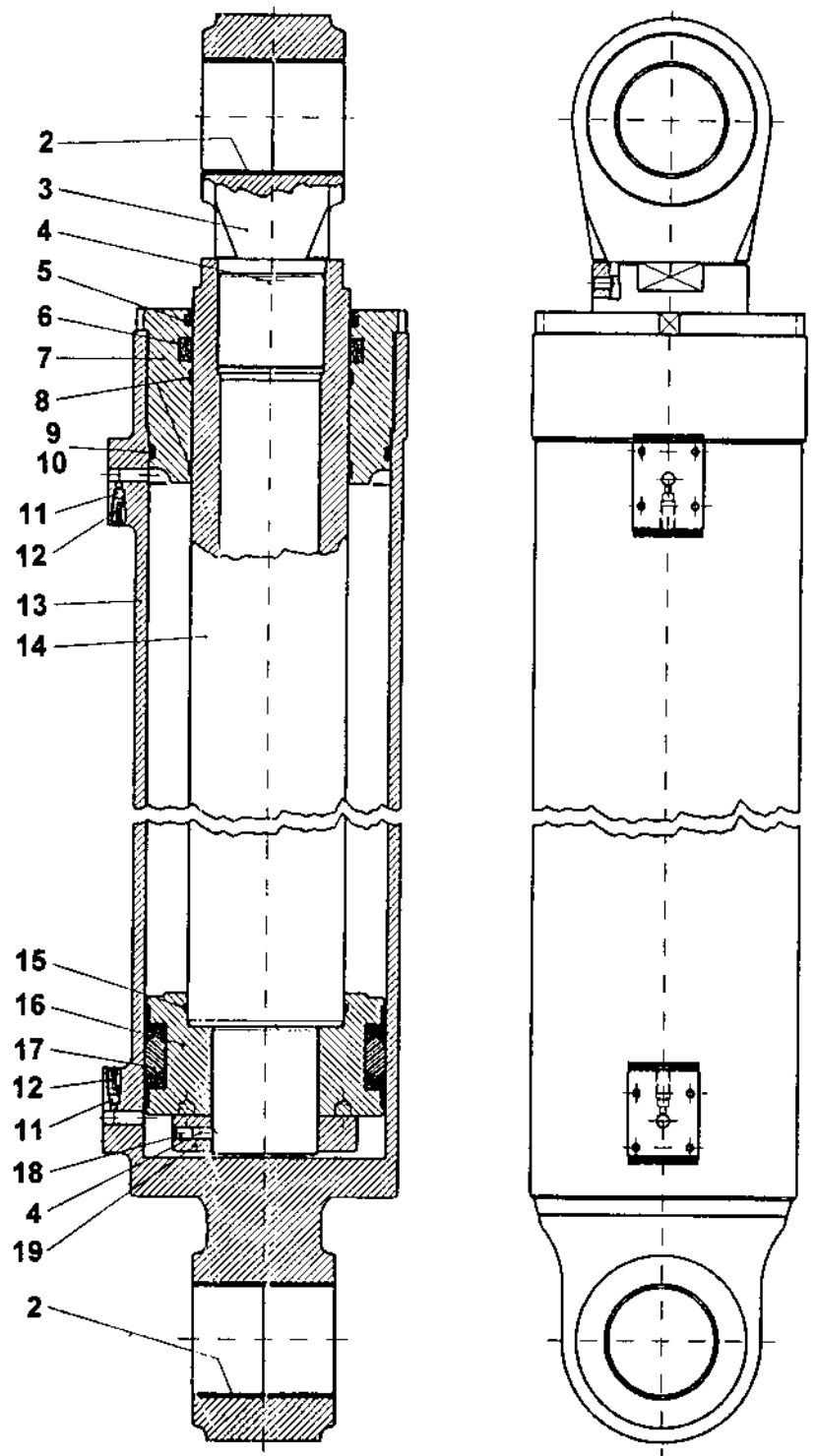
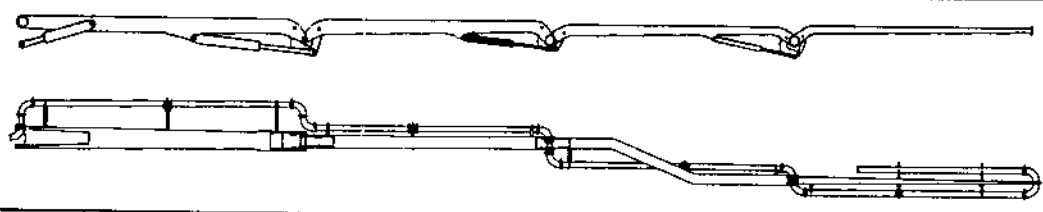

REVISION:

ITEM NO.	REED'S PARTS NO.	DESCRIPTION					QTY
		1	2	3	4	5	
-1	C-2B3	Assembly, Third Boom Cylinder (See Group 90, Figure 01 for NHA)					Ref
2	C-CD075.080050	• Bearing, Anti Friction					4
3	C-2B308	• Cap, Rod					2
4	C-VG122.081215	• Screw					1
5	C-BR310.110	• Gasket, Seal					1
6	C-BT110.110	• Gasket, Seal					1
7	C-2B301	• Head, Slide Rod					1
8	C-AG122.110	• Ring, Slide Rod					2
9	C-AP110.362	• Seal, Gasket					1
10	C-AO120.362	• Ring, Sealing					1
11	C-CS100.007	• Ball, Steel					2
12	C-WPVS1	• Valve, Air Hole					2
13	C-2B302	• Cylinder					1
14	C-2B307	• Rod					1
15	C-AO420.4437	• Ring, Seal					1
16	C-2B312	• Piston					1
17	C-BS226695511A	• Gasket, Seal					1
18	C-VG121.081212	• Screw					1
19	C-1B309	• Nut, Rod					1

DASH (-) ITEM NOT ILLUSTRATED

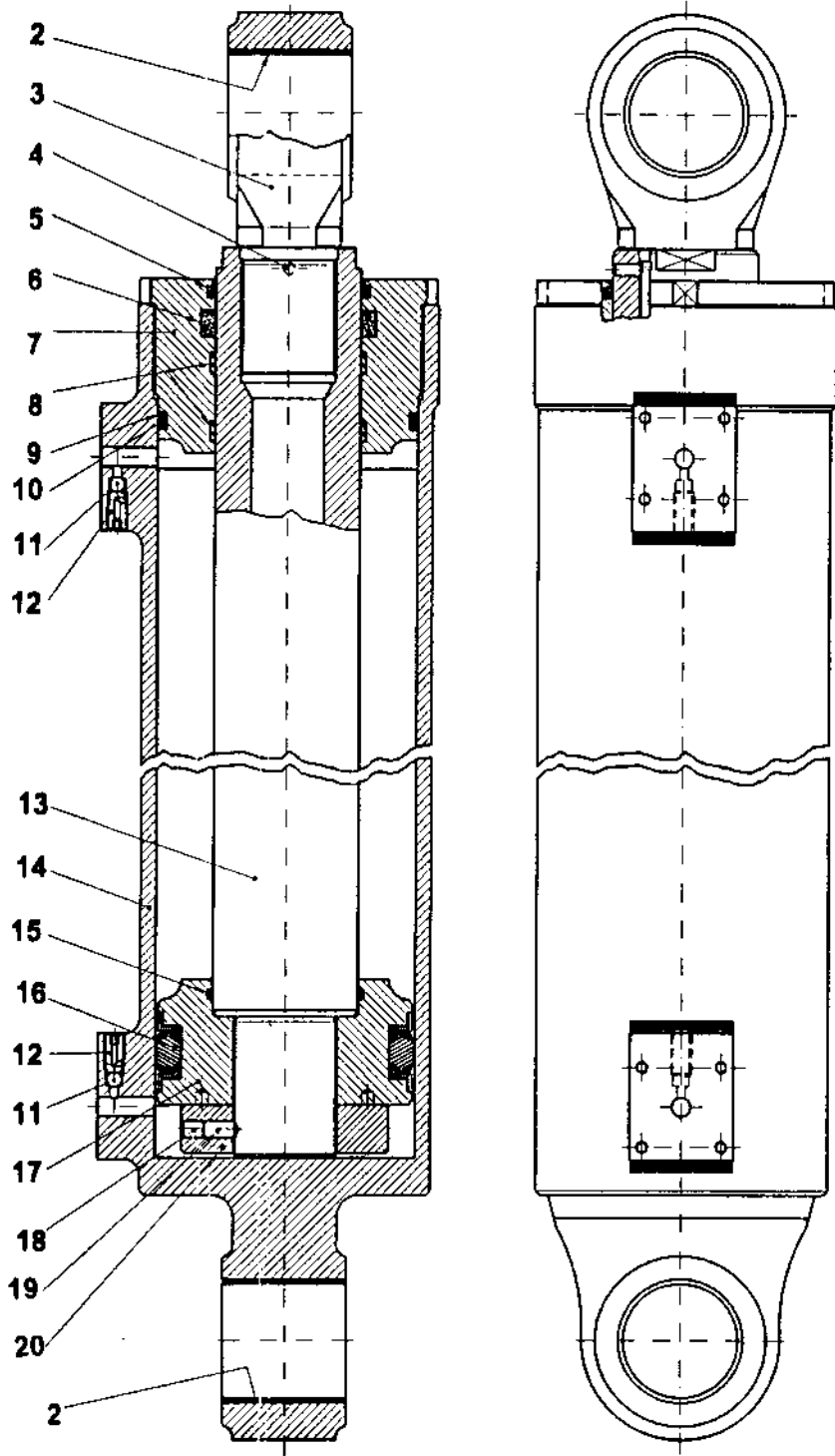
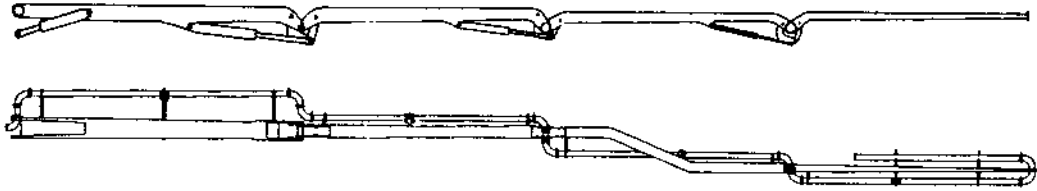

ITEM NO.	REED'S PARTS NO.	DESCRIPTION					QTY
		1	2	3	4	5	
-1	C-2B4	Assembly, Fourth Boom Cylinder (See Group 90, Figure 01 for NHA)					Ref
2	C-CD055.060060	• Bearing, Anti Friction					2
3	C-2B408	• Cap, Rod					4
4	C-VG122.061012	• Screw					1
5	C-BR310.070	• Gasket, Seal					1
6	C-BT110.070	• Gasket, Seal					1
7	C-2B401	• Head, Slide Rod					1
8	C-AG122.070	• Ring, Slide Rod					2
9	C-AP110.349	• Seal, Gasket					1
10	C-AO120.349	• Ring, Sealing					1
11	C-CS100.007	• Ball, Steel					2
12	C-WPVS1	• Valve, Air Hole					2
13	C-2B407	• Rod					1
14	C-2B402	• Cylinder					1
15	C-AO420.4275	• Ring, Sealing					1
16	C-BS23492393	• Gasket, Seal					1
17	C-2B412	• Piston					1
18	C-VG121.081212	• Screw					1
19	C-VG122.081215	• Screw					1
20	C-3B409	• Nut, Rod					1

DASH (-) ITEM NOT ILLUSTRATED

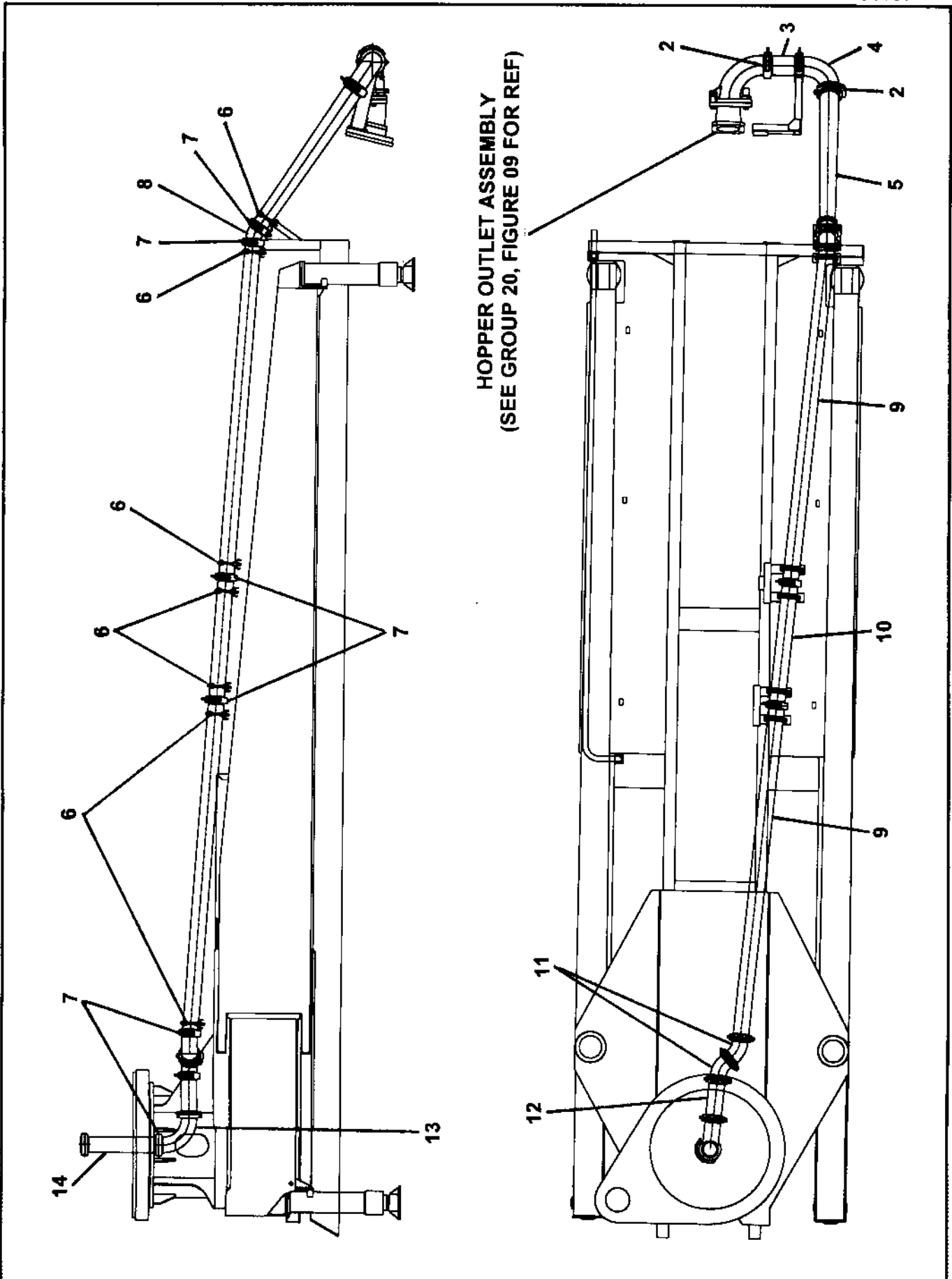

ITEM NO.	REED'S PARTS NO.	DESCRIPTION					QTY
		1	2	3	4	5	
-1	90-10	Assembly, Deck Area Concrete Pipe Line (See Group 90, Figure 01 for NHA)					Ref
2	72242	• Gasket, 6 Inch Clamp					2
3	801558	• Adapter, Hose Elbow					1
4	800336	• Elbow, 6 Inch 90					1
5	800326	• Reducer, 6 Inch to 5 Inch					1
6	800341	• U-Clamp, 5 Inch Pipe					7
7	W-101779	• Coupling, 6 Inch Clamp					2
8	800328	• Elbow, 5 Inch 30					1
9	800323	• Pipe, 5 Inch Deck					2
10		• Pipe, 5 Inch Deck					1
11	800327	• Elbow, 5 Inch 45					2
12		• Pipe, 5 Inch Deck					1
13		• Elbow, 5 Inch 90					2
14		• Pipe, 5 Inch					1

DASH (-) ITEM NOT ILLUSTRATED



CONCRETE PIPE LINE ASSEMBLY (BOOM AREA)

XXT 42
PARTS
GROUP 90
FIGURE 11
PAGE 01

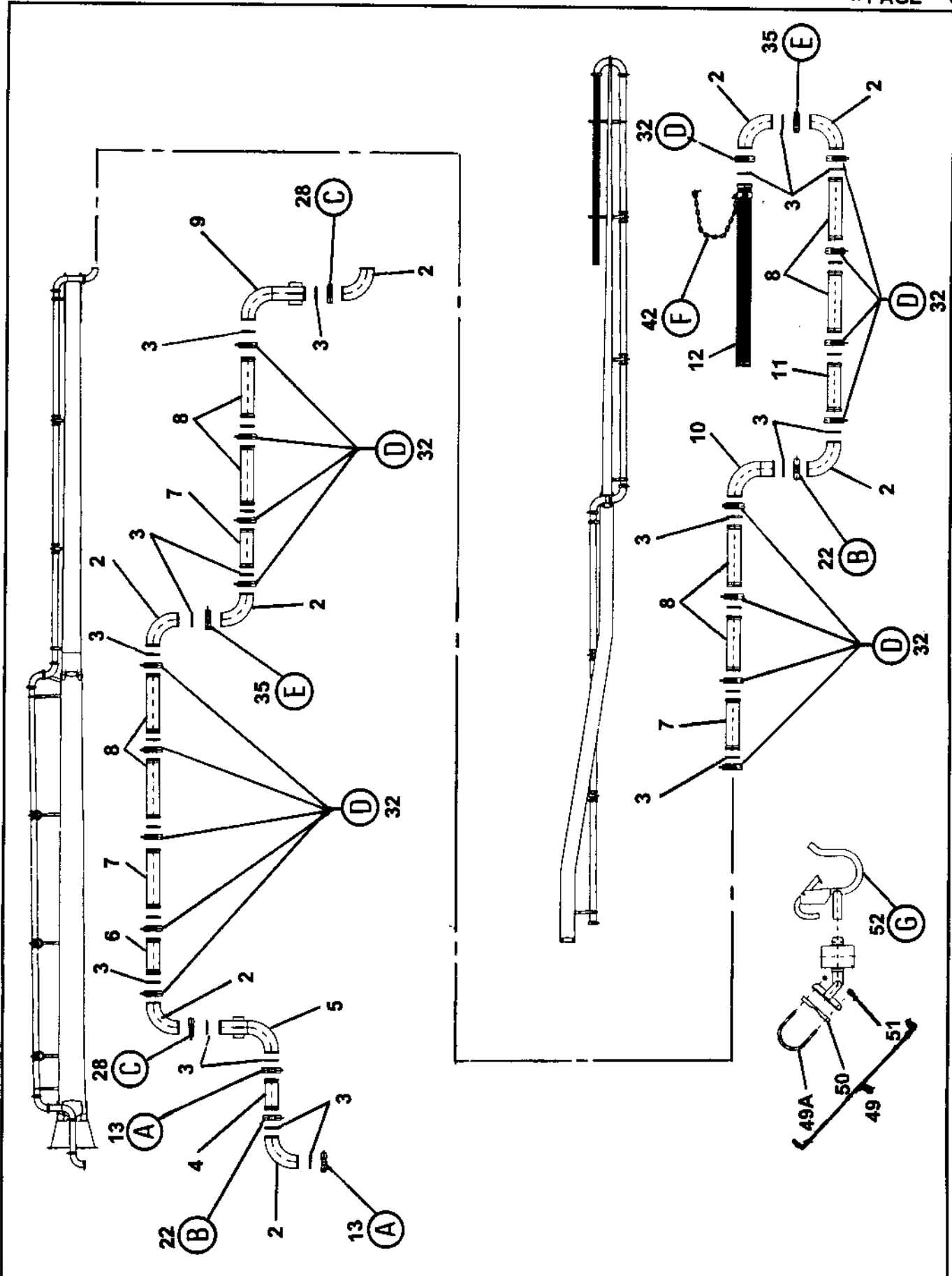

REVISION:

ITEM NO.	REED'S PARTS NO.	DESCRIPTION					QTY
		1	2	3	4	5	
-1	C-2T	Assembly, Boom Area Concrete Pipeline (See Group 90, Figure 01 for NHA)					Ref
2	801100	• Elbow, 90					8
3	C-TB125	• Gasket, Seal					26
4	801105-*	• Pipe					1
5	801672	• Pipe with Bend					1
6	801105-*	• Pipe					1
7	801105-3000	• Pipe					5
8	801105-*	• Pipe					8
9	801673	• Pipe with Bend					1
10	C-TM2.0360	• Pipe with Bend					1
11	C-TT2.2700	• Pipe					1
12	C-TT2.FLEX	• Hose, Flexible Max 4m					1
13	C-TG222	• Coupling, Bracket 2 Bolts					2
22	C-TG221	• Coupling, 2 Bolts					2
28	C-TG213	• Coupling, Lever					2
32	C-TG211	• Coupling, Lever					18
35	C-TG214	• Coupling, Bracket Lever					2
42	C-TS24	• Kit, Safety Collar					1
49	800341	• Assembly, U - Clamp					26
49A	C-TS212	• • Collar					1
50	C-TS001	• • Plate, Plastic					1
51	C-VD221.1420	• • Nut, Self Locking					2
52	C-TS23	• Kit, Flexible Hose Support					2

* REFER TO SPECIFIC SHEET FOR YOUR MODEL AND SERIAL NUMBER OF UNIT

DASH (-) ITEM NOT ILLUSTRATED

CONCRETE PIPE LINE ASSEMBLY (BOOM AREA)

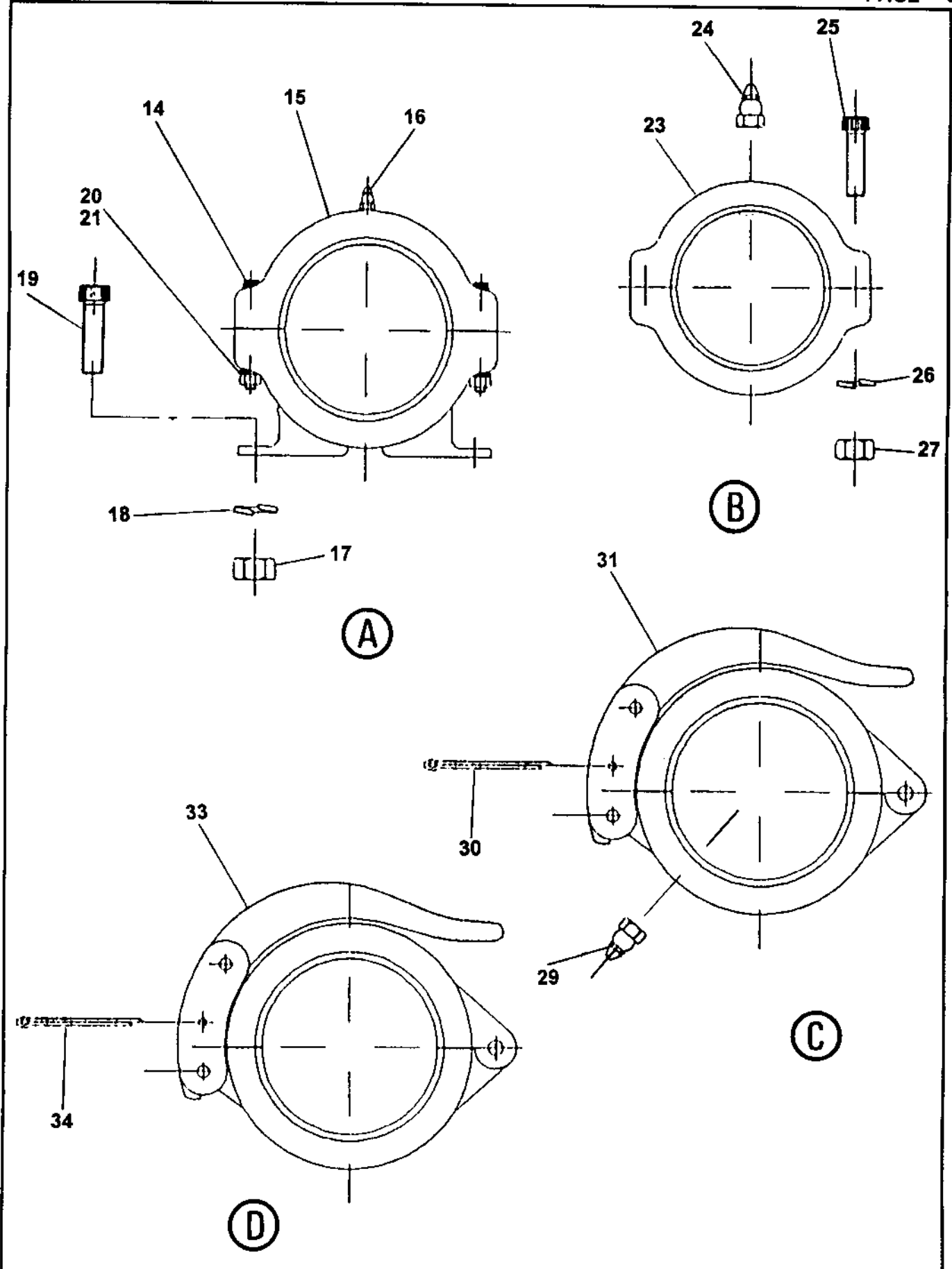

ITEM NO.	REED'S PARTS NO.	DESCRIPTION					QTY
		1	2	3	4	5	
13	C-TG222	•	•	•	•	•	2
14	C-VC112.121755	••	•	•	•	•	2
15	C-TG222.01	••	•	•	•	•	1
16	C-VI131.1010	••	•	•	•	•	1
17	C-VD111.1420	••	•	•	•	•	2
18	C-UE110.14	••	•	•	•	•	2
19	C-VC110.142035	••	•	•	•	•	2
20	C-UE110.12	••	•	•	•	•	2
21	C-VD111.1217	••	•	•	•	•	2
22	C-TG221	•	•	•	•	•	2
23	C-TG221.01	••	•	•	•	•	1
24	C-VI131.1010	••	•	•	•	•	1
25	C-VC110.121755	••	•	•	•	•	2
26	C-UE110.12	••	•	•	•	•	2
27	C-VD111.1217	••	•	•	•	•	2
28	C-TG213	•	•	•	•	•	2
29	C-VI131.1010	••	•	•	•	•	1
30	C-VS210.08040	••	•	•	•	•	1
31	C-TG211.01	••	•	•	•	•	1
32	C-TG211	•	•	•	•	•	18
33	C-TG211.01	••	•	•	•	•	1
34	C-VS210.08040	••	•	•	•	•	1

DASH (-) ITEM NOT ILLUSTRATED

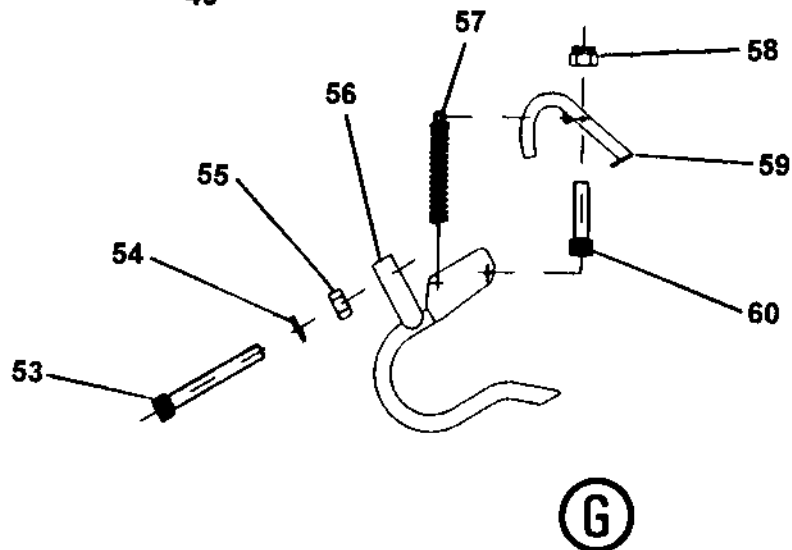
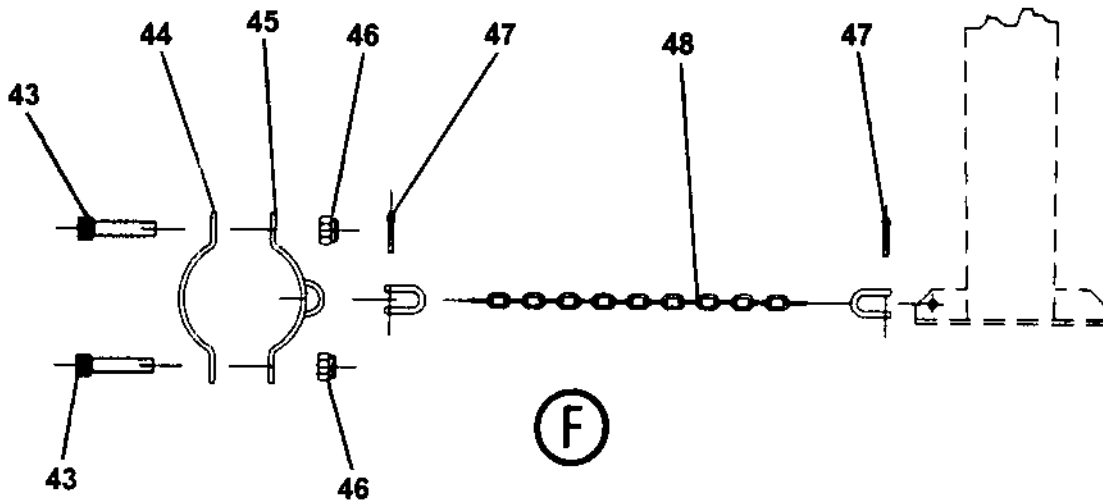
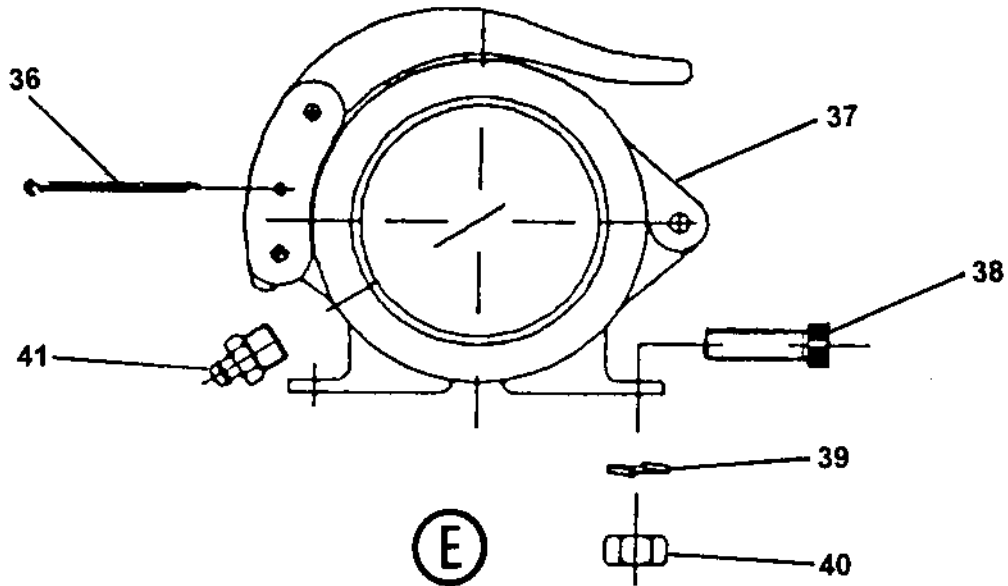

ITEM NO.	REED'S PARTS NO.	DESCRIPTION					QTY
		1	2	3	4	5	
35	C-TG214	• Coupling, Bracket Lever					2
36	C-VS210.08040	• • Pin, Split					1
37	C-TG212.01	• • Coupling					1
38	C-VC110.142035	• • Screw					2
39	C-UE110.14	• • Washer, Elastic					2
40	C-VD111.1420	• • Nut					2
41	C-VI131.1010	• • Nipple, Grease					1
42	C-TS24	• Kit, Safety Collar					1
43	C-VC110.101560	• • Screw					2
44	C-TS241	• • Collar, Safety					1
45	C-TS242	• • Connecting, Safety Collar					1
46	C-VD221.1015	• • Nut					2
47	C-AC910.1	• • Plate, Shackles Die					2
48	C-TG221	• • Chain Safety					1
52	C-TS23	• Kit, Flexible Hose Support					2
53	C-VC110.081270	• • Screw					1
54	C-UE110.08	• • Washer, Elastic					1
55	C-VD211.0812	• • Nut					1
56	C-TS231	• • Support, Flexible Hose					1
57	C-LT020.015096	• • Spring					1
58	C-VD221.0812	• • Nut, Self Locking					1
59	C-TS232	• • Lever, Locking					1
60	C-VC110.081260	• • Screw					1

DASH (-) ITEM NOT ILLUSTRATED